

本手册是华拓自动化有限公司的产品概述。
若图片与实物有所出入，请以实物为准。用户如需我公司更多产品资料，请与我公司市场部联系。

HUATOP® 华拓®

华拓自动化有限公司
HUATOP AUTOMATION CO., LTD.

地址：浙江省乐清市柳市镇前窑村
Add: Qianyao, Liushi, Yueqing, Zhejiang, China.
电话/Tel: +86 0577-62702932 QQ: 1678455158
手机/Mob: +86 18066339687 Skype: mike.chin22
邮箱/Email: mi-ke@outlook.com huatop@huatop.cn
网址/Web: www.huatop.cn www.huatop.cn

代理商 Agents:

HUATOP®
华拓自动化

产品目录本
CATALOGUE

HUATOP®
华拓自动化

BEST AUTOMATION

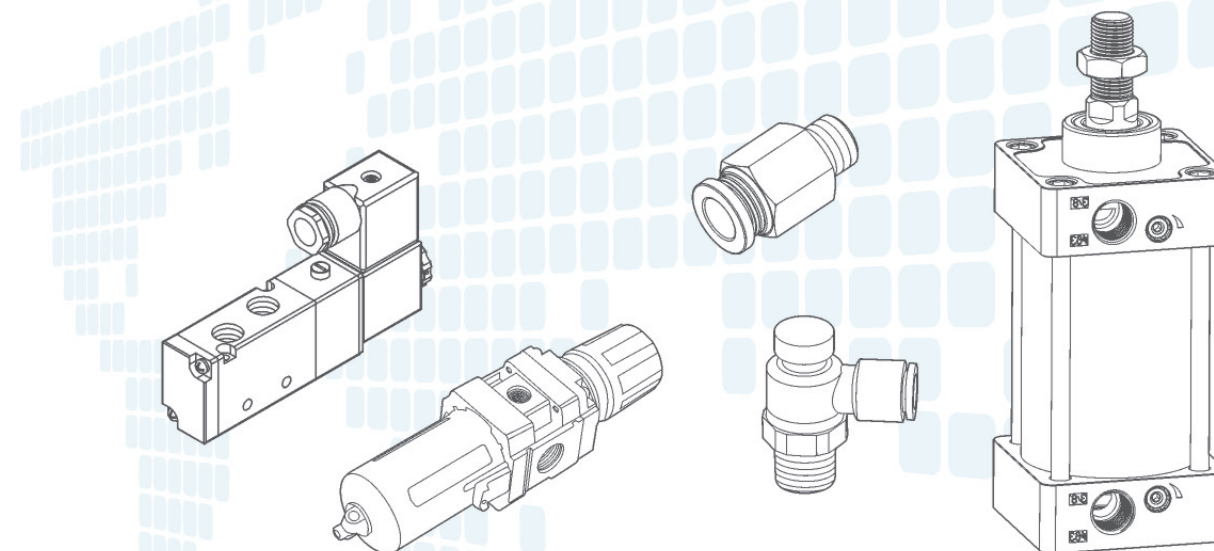

华拓自动化有限公司
HUATOP AUTOMATION CO., LTD.

企业简介 About Us

华拓自动化有限公司是一家专业从事自动化产品的生产企业，公司专注于工业自动化领域的技术研发、产品创新和实践应用，以实现生产效能最大化和服务全球自动化为目标，为客户提供高效、智能、精准和低耗的工业自动化整体解决方案。

公司主要产品有：接头、气源处理件、气缸、阀、传感器、机械手、伺服电机、电子元件等。公司产品规格齐全、质量可靠，价格合理，深受广大用户的信赖和好评。

公司秉承“质量第一，信誉为本，客户至上”的服务宗旨，热忱欢迎新老客户惠顾，期待大家携手合作，共创美好未来。

HUATOP AUTOMATION is a professional manufacturer of automation products. We focus on technology development, product innovation and application of industry automation. We are aimed at the maximum production efficiency and global automation services, offering customers high efficiency, intelligent, accurate and low consumption of complete industry automation solution.

The main products of HUATOP are fitting, air combination, cylinder, valve, sensor, robot arm, servo motor, electronic components, etc. Our products with complete specification, good quality, reasonable price has won trust and favorable comments from the masses of users deeply.

HUATOP inherits the service tenet of "quality first, based on prestige, customer upmost", we sincerely you to visit us and look forward to your cooperation to create a better future.

气源处理元件 Air Treatment Components

01	AC系列F.R.L三联件	AC Series F.R.L Three Units
01	AC系列F.R.L二联件	AC Series F.R.L Two Units
01	AW系列调压过滤器	AW Series Filter & Regulator
01	AF系列空气过滤器	AF Series Air Filter
01	AR系列调压阀	AR Series Regulator
02	AL系列油雾器	AL Series Oil Lubricator
02	QTY系列调压阀	QTY Series Regulator
02	QTYH系列高压调压阀	QTYH Series High Pressure Regulator
02	QSL系列空气过滤器	QSL Series Filter
02	QIU系列油雾器	QIU Series Oil Lubricator
03	A/B系列F.R.L三联件	A/B Series F.R.L Three Units
03	A/B系列F.R.L二联件	A/B Series F.R.L Two Units
03	A/B系列调压过滤器	A/B Series Filter & Regulator
03	A/B系列空气过滤器	A/B Series Filter
03	A/B系列调压阀	A/B Series Regulator
03	A/B系列油雾器	A/B Series Oil Lubricator
04	GC系列F.R.L三联件	GC Series F.R.L Three Units
04	GFC系列F.R.L二联件	GFC Series F.R.L Two Units
04	GFR系列调压过滤器	GFR Series Filter & Regulator
04	GF系列空气过滤器	GF Series Filter
04	GR系列调压阀	GR Series Regulator
04	GL系列油雾器	GL Series Lubricator
05	FOU系列F.R.L三联件	FOU Series F.R.L Three Units
05	FRC系列F.R.L二联件	FRC Series F.R.L Two Units
05	LFR系列调压过滤器	LFR Series Filter & Regulator
05	LF系列空气过滤器	LF Series Filter
05	LR系列调压阀	LR Series Regulator
05	LOE系列油雾器	LOE Series Oil Lubricator
06	UFRL系列F.R.L三联件	UFRL Series F.R.L Three Units
06	UFR/L系列F.R.L二联件	UFR/L Series F.R.L Two Units
06	UFR系列调压过滤器	UFR Series Filter & Regulator
06	UF系列空气过滤器	UF Series Filter
06	UR系列调压阀	UR Series Regulator
06	UL系列油雾器	UL Series Oil Lubricator
07	C系列F.R.L三联件	C Series F.R.L Three Units
07	C系列F.R.L二联件	C Series F.R.L Two Units
07	W系列调压过滤器	W Series Filter & Regulator
07	F系列空气过滤器	F Series Filter
07	R系列调压阀	R Series Regulator
07	L系列油雾器	L Series Oil Lubricator
08	39系列F.R.L三联件	39 Series F.R.L Three Units
08	39系列F.R.L二联件	39 Series F.R.L Two Units
08	39系列调压过滤器	39 Series Filter & Regulator
08	39系列空气过滤器	39 Series Filter
08	39系列调压阀	39 Series Regulator
08	39系列油雾器	39 Series Oil Lubricator
09	SFC系列F.R.L二联件	SFC Series F.R.L Two Units
09	SFR系列调压过滤器	SFR Series Filter & Regulator
09	SL系列油雾器	SL Series Oil Lubricator
09	MC系列F.R.L二联件	MC Series F.R.L Two Units
09	MC系列调压过滤器	MC Series Filter & Regulator
09	MC系列油雾器	MC Series Oil Lubricator

10	MC系列过滤器	MC Series Filter
10	QSLH系列高压调压阀	QSLH Series High Pressure Regulator
10	QFLH系列高压过滤器	QFLH Series High Pressure Filter
10	QFRH系列高压调压过滤器	QFRH Series High Pressure Filter&Regulator
10	AD系列末端自动排水器	AD Series Auto Drainer
10	ITV系列电气比例阀	ITV Series Electro-Pneumatic Regulator
11	IR系列精密调压阀	IR Series Precision Regulator
11	AMD系列微雾分离器	AMD Series Micro Mist Separator
	AMG系列水份分离器	AMG Series Water Separator
11	气源配件	Air Treatments Accessory

控制元件 Control Components

12	VP系列电磁阀	VP Series Solenoid Valve
12	2P/2V025/3V1系列电磁阀	2P/2V025/3V1 Series Solenoid Valve
12	3V系列电磁阀	3V Series Solenoid Valve
12	4V系列电磁阀	4V Series Solenoid Valve
13	4M系列电磁阀	4M Series Solenoid Valve
13	MVSC系列电磁阀	MVSC Series Solenoid Valve
13	263/802/2630系列电磁阀	263/802/2630 Series Solenoid Valve
14	F5214系列电磁阀(老虎阀)	F5214 Series Solenoid Valve(Tiger Valve)
14	VF系列电磁阀	VF Series Solenoid Valve
14	SY系列电磁阀	SY Series Solenoid Valve
14	SYA系列气控阀	SYA Series Air Control Valve
15	Q22HD系列气控阀	Q22HD Series Air Control Valve
15	VT307/VX2120系列气控阀	VT307/VX2120 Series Solenoid valve
15	VTA301/VTA315系列气控阀	VTA301/VTA315 Series Air Control Valve
15	3A系列气控阀	3A Series Air Control Valve
15	4A系列气控阀	4A Series Air Control Valve
16	JM/JMJ/M3/M5系列机械阀	JM/JMJ/M3/M5 Series Mechanical Valve
17	MV/MOV系列机械阀	MV/MOV Series Mechanical Valve
17	S3-210/S3系列机械阀	S3-210/S3 Series Mechanical Valve
18	CM3系列机械阀	CM3 Series Mechanical Valve
18	VM130、VM131系列机械阀	VM130、VM131 Series Mechanical Valve
18	VM230系列机械阀	VM230 Series Mechanical Valve
18	3H/4H系列手扳阀	3H/4H Series Hand Lever Valve
19	3L/4L系列手拉阀	3L/4L Series Hand Draw Valve
19	JM/SH/SR/4HV系列手拉阀	JM/SH/SR/4HV Series Hand Draw Valve
20	HV/VH系列手转阀	HV/VH Series Hand Rotary Valve
20	3F/4F/FV/ST系列脚踏阀	3F/4F/FV/ST Series Foot Valve
21	K系列脚踏阀	K Series Foot Valve
21	CV/LCV系列单向阀	CV/LCV Series Check Valve
21	ST/KV系列梭阀	ST/KV Series Shuttle Valve
21	KKP/QE系列快速排气阀	KKP/QE Series Quick Exhaust Valve
22	BQE/SEU系列快速排气阀	BQE/SEU Series Quick Exhaust Valve
22	KLA系列单向节流阀	KLA Series One Way Throttle Valve
22	ASC/RE系列流量控制阀	ASC/RE Series Speed Control Valve
23	SMF系列电磁脉冲阀	SMF Series Solenoid Pulse Valve
23	SMF-Y系列淹没式电磁脉冲阀	SMF-Y Series Submerged Pulse Valve
23	SMF-Z系列管式电磁脉冲阀	SMF-Z Series Pipe Connected Type Pulse Valve
23	ASV200系列不锈钢角座阀	ASV200 Series Stainless Steel Angle Seat Valve
23	ASV200-S系列不锈钢角座阀	ASV200-S Series Stainless Steel Angle Seat Valve
23	JZF系列不锈钢角座阀	JZF Series Stainless Steel Angle Seat Valve
24	JZF-S系列不锈钢角座阀	JZF-S Series Stainless Steel Angle Seat Valve

24	AT系列气动执行器	AT Series Pneumatic Actuator
24	Q641F系列气动法兰球阀	Q641F Series Pneumatic Flanged Ball Valve
24	D671X系列气动对夹蝶阀	D671X Series Pneumatic Wafer Butterfly Valve
24	D943系列电动硬密封对夹蝶阀	D943 Series Electric Wafer Butterfly Valve
25	2S系列不锈钢电磁阀	2S Series Solenoid Valve With Stainless Steel Body
25	2WB系列不锈钢电磁阀	2WB Series Solenoid Valve With Stainless Steel Body
25	PU220S系列不锈钢电磁阀	PU220S Series Solenoid Valve With Stainless Steel Body
25	2WBK系列不锈钢电磁阀	2WBK Series Solenoid Valve With Stainless Steel Body
25	2WBF系列不锈钢电磁阀	2WBF Series Solenoid Valve With Stainless Steel Body
26	2W系列电磁阀	2W Series Solenoid Valve
26	2WS防水系列电磁阀	2WS Series Water Proof Solenoid valve
26	2WA系列电磁阀	2WA Series Solenoid Valve
26	2L系列耐高温电磁阀	2L Series Solenoid Valve (High Temperature Resistant Type)
26	2WK系列电磁阀	2WK Series Solenoid Valve
27	2WG系列耐高温电磁阀	2WG Series Solenoid Valve (High Temperature Resistant Type)
27	PU220/PU225系列电磁阀	PU220/PU225 Series Solenoid Valve
27	VX系列通电磁阀	VX Series Solenoid Valve
27	2Q系列气控阀	2Q Series Air Control Valve
27	2WBB系列电磁阀	2WBB Series Solenoid Valve
28	Q22\Q23系列电磁阀	Q22\Q23 Seires Solenoid Valve
28	OPT-A/B系列电子排水阀	OPT-A/B Electronic Drain Valve
28	SCG/2VT系列电磁阀	SCG/2VT Series Solenoid Valve
28	2WF/FB2E/DC231系列电磁阀	2WF/FB2E/DC231 Series Solenoid Valve
28	LT23JD系列电磁阀	LT23JD Series Solenoid Valve
28	A系列气控阀	A Series Air Control Valve
29	HFS系列控制阀	HFS Series Control Valve
29	BV系列安全阀	BV Series Safety Valves
29	K系列滑柱式换向阀	K Series Control Change Solenoid Valve
29	VHS系列残压释放阀	VHS Series Pressure Relief Valve
29	QPM/QPF-1系列压力开关	QPM/QPF-1 Series Pressure Control Switch
30	CBP系列单压开关	CBP Series Single Pressure Control Switch
30	CBP系列双压开关	CBP Series Double Pressure Control Switch
30	PS/RNS系列压力开关	PS/RNS Series Pressure Control Switch
30	HSV系列滑动开关	HSV Series Hand Slide Valve
30	HL/SHL系列钮子开关	HL/SHL Series Knob Switch Valve
31	AV系列直动式电磁阀	AV Series Solenoid Valve
31	TXTJF系列常闭直动式电磁阀	TXTJF Series Solenoid Valve
31	TX2120系列常闭直动式电磁阀	TX2120 High Pressure Solenoid Valve
31	5404系列高压系列电磁阀	5404 Serise High Pressure Solenoid Valve
31	6213/0927系列电磁阀	6213/0927 Series Solenoid Valve
31	NS系列氮气弹簧	NS Series Nitrogen Spring
31	CPR系列二氧化碳调压阀	CPR Series Pressure Regulator
31	DBF系列空压碟式制动器	DBF Series Air Clutches Brake
31	K22JD/K23JD系列截止阀	K22JD/K23JD Series Cut-off Valve
31	K25JK系列气控阀	K25JK Series Air Control Valve
31	R/K/GT系列振动器	R/K/GT Series Vibrator
31	TK-10系列压力控制器	TK-10 Series Pressure Controller
31	ZSE系列压力开关	ZSE Series Pressure Control Switch
31	PIC-20X型脉冲喷吹控制仪	PIC-20X Series Pulse Vale Controller
31	SK系列敲击锤	SK Series Air Hammer
32	汇流板系列	Manifold Series
33	气动阀配件	Pneumatic Valve Accessory
36	真空发生器	Vacuum Ejector
38	真空吸盘	Vacuum Pad

执行元件 Executive Components

39	DSBC系列标准气缸	DSBC Series Standard Cylinder
39	DSBG系列标准气缸	DSBG series Standard Cylinder
39	DNC系列标准气缸	DNC Series Standard Cylinder
39	DNG系列标准气缸	DNG Series Standard Cylinder
39	C95/C96系列圆管拉杆式标准气缸	C95/C96 Series Standard Cylinder
40	CA2系列标准气缸	CA2 Series Standard Cylinder
40	CS1/CS2系列标准气缸	CS1/CS2 Series Standard Cylinder
40	CP95/CP96系列拉杆内藏式标准气缸	CP95/CP96 Series Standard Cylinder
40	MB系列拉杆式标准气缸	MB Series Standard Cylinder
40	SMB系列标准气缸	SMB Series Standard Cylinder
41	MB1系列拉杆内藏式标准气缸	MB1 Series Standard Cylinder
41	SE系列标准气缸	SE Series Standard Cylinder
41	SI系列标准气缸	SI Series Standard Cylinder
41	JSI系列标准气缸	JSI Series Standard Cylinder
41	SSI系列标准气缸	SSI Series Standard Cylinder
42	SC系列标准气缸	SC Series Standard Cylinder
42	SSC系列标准气缸	SSC series Standard Cylinder
42	SU系列标准气缸	SU Series Standard Cylinder
42	SG/SGC系列标准气缸	SG/SGC Series Standard Cylinder
43	QGA、QGB系列标准气缸	QGA、QGB Series Standard Cylinder
43	DSNU系列不锈钢迷你气缸	DSNU Series Stainless Steel Mini Cylinder
43	CG1系列铝合金轻型气缸	CG1 Series Aluminum Alloy Light-Duty Cylinder
43	C85系列不锈钢迷你气缸	C85 Series Stainless Steel Mini Cylinder
43	CM2B系列不锈钢迷你气缸	CM2B Series Stainless Steel Mini Cylinder
44	CJ1系列微型气缸	CJ1 Series Mini Cylinder
44	CJ2B系列不锈钢迷你气缸	CJ2B Series Stainless Steel Mini Cylinder
44	CJPB系列螺纹气缸(单作用)	CJPB Series Slim Cylinder (Single Acting)
44	CJP2系列微型气缸(双作用)	CJP2 Series Mini Cylinder (Double Acting)
44	PB/PBR系列笔形气缸	PB/PBR Series Pen Shape Cylinder
44	MAL/MBL系列铝合金迷你气缸	MAL/MBL Series Aluminum Alloy Slim Cylinder
45	SMAL系列不锈钢迷你气缸	SMAL Series Stainless Steel Mini Cylinder
45	MA系列不锈钢迷你气缸	MA Series Stainless Steel Mini Cylinder
45	MG系列不锈钢迷你气缸	MG Series Stainless Steel Mini Cylinder
45	MI系列不锈钢迷你气缸	MI Series Stainless Steel Mini Cylinder
45	DA系列直接安装型不锈钢迷你气缸	DA Series Stainless Steel Mini Cylinder
46	ADN/AEN系列超薄气缸	AND/AEN Series Compact Cylinder
46	ADVC/AEVC系列超薄气缸	ADVC/AEVC Series Compact Cylinder
46	ADVU系列超薄气缸	ADVU Series Compact Cylinder
46	DMM系列紧凑自由安装气缸	DMM Series Compact Free Installation Cylinder
46	CQSB系列薄型气缸	CQSB Series Compact Cylinder
47	CQ2B系列薄型气缸	CQ2B Series Compact Cylinder
47	CQMB系列带导杆超薄气缸	CQMB Series Guide Rod Type Compact Cylinder
47	RQ系列超薄气缸	RQ Series Compact Cylinder
47	CU系列自由安装型气缸	CU Series Free Installation Cylinder
47	CUJB系列小型自由安装型气缸	CUJB Series Mini Type Free Installation Cylinder
48	ZCUK系列真空用自由安装型气缸	ZCUK Series Vacuum Free Installation Cylinder
48	BDA系列自由安装气缸	BDA Series Free Installation Cylinder
48	MBDA系列自由安装气缸	MBDA Series Free Installation Cylinder
48	ACQ/TACQ系列薄型气缸	ACQ/TACQ Series Compact Cylinder
48	ACP系列超薄气缸	ACP Series Compact Cylinder
49	SSDA系列不锈钢薄型气缸	SSDA Series Stainless Steel Compact Cylinder
49	SDA/SSD2系列薄型气缸	SDA/SSD2 Series Compact Cylinder

49	DPZ系列双活塞杆气缸	DPZ Series Double Piston Rods Guide Cylinder
49	CXW系列双活塞杆气缸	CXW Series Double Piston Rods Guide Cylinder
50	FENG-GF/FENG-KF系列导向装置	FENG-GF/FENG-KF Series Guiding Device
50	DFM系列导向杆气缸	DFM Series Guide Rod Cylinder
50	CXS系列双轴气缸	CXS Series Double Piston Rods Guide Cylinder
50	CXSJ系列双联气缸	CXSJ Series Double Piston Rods Guide Cylinder
50	TB系列薄型带导杆气缸	TB Series Thin Type Guide Rod Cylinder
51	TD系列双活塞杆气缸	TD Series Double Piston Rods Guide Cylinder
51	MGP系列薄型带导杆气缸	MGP Series Thin Type Guide Cylinder
51	MGJ系列微型带导杆气缸	MGJ Series Micro Type Guide Cylinder
51	TCM/TCL系列薄型带导杆气缸	TCM/TCL Series Thin Type Guide Cylinder
51	TN/TR系列双活塞杆气缸	TN/TR Series Double Piston Rods Guide Cylinder
52	STM系列双活塞杆气缸	STM Series Double Piston Rods Cylinder
52	MGC系列带导杆气缸	MGC Series Guide Cylinder
52	MGG系列带导杆气缸	MGG Series Guide Cylinder
52	MY1系列机械式无杆气缸	MY1 Series Mech. Rodless Cylinder
52	CY3B/CY3R系列磁耦合无杆气缸	CY3B/CY3R Series Rodless Cylinder
53	CY1S系列磁耦合无杆气缸	CY1S Series Rodless Cylinder
53	CY1L系列磁耦合无杆气缸	CY1L Series Rodless Cylinder
53	RMS系列磁耦合无杆气缸	RMS Series Rodless Cylinder
53	RMT/RMTL系列磁耦合无杆气缸	RMT/RMTL Series Rodless Cylinder
53	MHL2系列气动手指	MHL2 Series Air Gripper
54	MHF2系列气动手指	MHF2 Series Air Gripper
54	MHC2系列气动手指	MHC2 Series Air Gripper
54	MHT2系列气动手指	MHT2 Series Air Gripper
54	MHY2系列气动手指	MHY2 Series Air Gripper
54	MIW/MIS系列气动手指	MIW/MIS Series Air Gripper
54	MHW2系列气动手指	MHW2 Series Air Gripper
55	MHZ2系列气动手指	MHZ2 Series Air Gripper
55	MHZL2系列气动手指	MHZL2 Series Air Gripper
55	HFP系列气动手指	HFP Series Air Gripper
55	HFR系列气动手指	HFR Series Air Gripper
55	HFY系列气动手指	HFY Series Air Gripper
55	HFZ系列气动手指	HFZ Series Air Gripper
56	HDM/HDP系列角度型机械爪	HDM/HDP Series Angle Type Mech. Claw
56	HDS系列气动手指	HDS Series Angular Gripper
56	TEJ系列气动夹具	TEJ Series Pneumatic Clamp
56	MHS系列气爪	MHS Sliding Rail Cylinder
56	MXJ/MXS/MXH/MXQ系列滑台气缸	MXJ/MXS/MXH/MXQ Series Slide Cylinder
56	SCR(L)系列转角气缸	SCR(L) Series Rotary Cylinder
56	MK/MK2系列旋转气缸	MK/MK2 Series Rotary Cylinder
57	CK1系列夹紧气缸	CK1 Series Clamp Cylinder
57	CRB1系列大型叶片式摆动气缸	CRB1 Series Large Vane Swing Cylinder
57	CRB2BW系列叶片式摆动气缸	CRB2BW Series Vane Swing Cylinder
57	CRBU2W系列叶片式摆动气缸	CRBU2W Series Vane Swing Cylinder
57	CRA1系列摆动气缸	CRA1 Series Rotary Cylinder
57	MSQ系列摆动气缸	MSQ Series Rotary Cylinder
58	CRQ2系列摆动气缸	CRQ2 Series Rotary Cylinder
58	MRHQ系列摆台气爪	MRHQ Series Rotary Gripper
58	MSZ系列摆动气缸	MSZ Series Rotary Cylinder
58	ACK系列旋转气缸	ACK Series Rotary Cylinder
58	ASC系列全螺纹转角气缸	ASC Series Full Thread Corner Cylinder
58	SRC系列旋转气缸	SRC Series Rotary Cylinder
59	JGL系列杠杆夹持气缸	JGL Series Lever Clamping Cylinder

59	TWQ系列止动气缸	TWQ Series Stop Cylinder
59	TWH系列止动气缸	TWH Series Stop Cylinder
59	TWG系列止动气缸	TWG Series Stop Cylinder
59	RTP系列摆动气缸	RTP Series Rotary Cylinder
59	RTH系列摆动气缸	RTH Series Rotary Cylinder
60	ZH系列气液转换器	ZH Series Air-Liquid Converter
60	QGZN系列气液阻尼缸	QGZN Series Air-Liquid Damping Cylinder
60	PM系列打刀气缸	PM Series Strike Knife Cylinder
60	MPT/MPTF/MPTS系列气液增压缸	MPT/MPTF/MPTS Series Boosting Cylinder
60	MPTC/MPTD系列气液增压缸	MPTC/MPTD Series Boosting Cylinder
61	BF系列低摩擦气缸	BF Series Lower Friction Cylinder
61	HTCS系列低摩擦气缸	HTCS Series Lower Friction Cylinder
61	HTCC系列低摩擦比例气缸	HTCC Series Lower Friction Proportional Cylinder
61	ZQ系列拖链	ZQ Series Cable Track Towing Chain
61	HGH系列直线导轨	HGH Series Linear Guides
61	OST/OSP派克型机械式无杆气缸	OST/OSP Parker Type Mech. Rodless Cylinder
61	HTA系列伺服电缸	HTA Series Servo Electric Cylinder
61	HTB系列伺服电缸	HTB Series Servo Electric Cylinder
61	HTC系列伺服电缸	HTC Series Servo Electric Cylinder
62	气动压力机	Air Press
62	密封圈	Seals
63	气缸附件	Cylinder Accessories
66	磁性开关/气缸套件	Magnetic Switch/Cylinder Kits

辅助元件 Auxiliary Components

67	微型快插接头/铁快插接头	Mini One Touch Fitting/Iron One Touch Fitting
68	塑料快插接头	Plastic One Touch Fitting
73	SMC型快插接头	SMC Type One Touch Fitting
76	旋转接头	Rotary One Touch Fitting
77	流量控制阀/单向阀	Flow Control Valve/Check Valve
78	公制内置封闭式快插接头	Meter Type Stop Fitting
78	压缩空气管道接头	Compressed Air System Fitting
79	W系列净水管快速接头	W Series Water Adaptors
79	F系列光纤透明接头	F Series Optical Fiber Transparent Fitting
80	快拧接头	Fast Twist Fitting
81	卡套接头	Ferrule Fitting
82	C式快速接头	C Type Quick Couplers
84	不锈钢快插接头	Stainless Steel One Touch Fitting
85	全铜快插接头	Brass One Touch Fitting
86	SCQ系列球阀	SCQ Series Ball Valve
87	消声器	Silencers
88	吹尘枪/气管剪/气管卡/卷管器	Air Gun/Tube Cutter/Tube STRAP/Auto Hose Reel
89	气管	Pneumatic Tube
93	华拓牌HT系列自锁式尼龙扎带	HUATOPHT Series Self-Locking Nylon Cable Ties

液压元件 Hydraulic Components

94	MO/HO系列液压缸	MOB/HO Series Hydraulic Cylinder
94	G02/G03系列液压电磁阀	G02/G03 Series Hydraulic Solenoid Valve
95	油压缓冲器	Shock Absorbers
96	CIT系列液压单向阀	CIT Series Check Valve
96	KC液压流量控制阀	KC Series Hydraulic Control Valve
96	液压快速接头	Hydraulic Quick Couplings

AC系列F.R.L三联件 AC Series F.R.L Three Units

Operating Pressure: 使用压力: 0~0.8Mpa	新款 New Type		老款 Old Type		型号 Model	螺纹尺寸 Port Size	额度流量 Rated Flow	压力表 Pressure Gauge	使用温度 Operating Temperature	排水类型 Drain Type	说明 Notes
						AC1000-M5	M5	90 L/min	Y30-10-M5	5~60°C	排水类型: -空白: 差压排水 -M: 手动排水 -A: 自动排水 Drain Type: -Blank: Pressure Drain -M: Manual Drain -A: Automatic Drain
					AC2000-02	PT1/4	500 L/min	Y40-10-1/8	5~60°C		
					AC2500-02	PT1/4	1700 L/min	Y40-10-1/8	5~60°C		
					AC3000-02	PT1/4	1700 L/min	Y40-10-1/8	5~60°C		
					AC3000-03	PT3/8	2000 L/min	Y40-10-1/8	5~60°C		
					AC4000-04	PT1/2	3000 L/min	Y50-10-1/4	5~60°C		
					AC4000-06	PT3/4	3000 L/min	Y50-10-1/4	5~60°C		
					AC5000-06	PT3/4	5000 L/min	Y50-10-1/4	5~60°C		
					AC5000-10	PT1	5000 L/min	Y50-10-1/4	5~60°C		

AC系列F.R.L二联件 AC Series F.R.L Two Units

Operating Pressure: 使用压力: 0~0.8Mpa	新款 New Type		老款 Old Type		型号 Model	螺纹尺寸 Port Size	额度流量 Rated Flow	压力表 Pressure Gauge	使用温度 Operating Temperature	排水类型 Drain Type	说明 Notes
						AC1010-M5	M5	90 L/min	Y30-10-M5	5~60°C	排水类型: -空白: 差压排水 -M: 手动排水 -A: 自动排水 Drain Type: -Blank: Pressure Drain -M: Manual Drain -A: Automatic Drain
					AC2010-02	PT1/4	500 L/min	Y40-10-1/8	5~60°C		
					AC20A-02E-CR	PT1/4	1700 L/min	Y40-10-1/8	5~60°C		
					AC3010-02	PT1/4	1700 L/min	Y40-10-1/8	5~60°C		
					AC3010-03	PT3/8	2000 L/min	Y40-10-1/8	5~60°C		
					AC4010-04	PT1/2	3000 L/min	Y50-10-1/4	5~60°C		
					AC4010-06	PT3/4	3000 L/min	Y50-10-1/4	5~60°C		
					AC5010-06	PT3/4	5000 L/min	Y50-10-1/4	5~60°C		
					AC5010-10	PT1	5000 L/min	Y50-10-1/4	5~60°C		

AW系列调压过滤器 AW Series Filter & Regulator

Operating Pressure: 使用压力: 0~0.8Mpa	新款 New Type		老款 Old Type		型号 Model	螺纹尺寸 Port Size	额度流量 Rated Flow	压力表 Pressure Gauge	使用温度 Operating Temperature	排水类型 Drain Type	说明 Notes
						AW1000-M5	M5	100 L/min	Y30-10-M5	5~60°C	排水类型: -空白: 差压排水 -M: 手动排水 -A: 自动排水 Drain Type: -Blank: Pressure Drain -M: Manual Drain -A: Automatic Drain
					AW2000-02	PT1/4	550 L/min	Y40-10-1/8	5~60°C		
					AW3000-02	PT1/4	2000 L/min	Y40-10-1/8	5~60°C		
					AW3000-03	PT3/8	2000 L/min	Y40-10-1/8	5~60°C		
					AW4000-04	PT1/2	4000 L/min	Y50-10-1/4	5~60°C		
					AW4000-06	PT3/4	4500 L/min	Y50-10-1/4	5~60°C		
					AW5000-06	PT3/4	5500 L/min	Y50-10-1/4	5~60°C		
					AW5000-10	PT1	5500 L/min	Y50-10-1/4	5~60°C		

AF系列空气过滤器 AF Series Air Filter

Operating Pressure: 使用压力: 0~0.8Mpa	新款 New Type		老款 Old Type		型号 Model	螺纹尺寸 Port Size	额度流量 Rated Flow	使用温度 Operating Temperature	排水类型 Drain Type	说明 Notes
						AF1000-M5	M5	110 L/min	5~60°C	排水类型: -空白: 差压排水 -M: 手动排水 -A: 自动排水 Drain Type: -Blank: Pressure Drain -M: Manual Drain -A: Automatic Drain
					AF2000-02	PT1/4	750 L/min	5~60°C		
					AF3000-02	PT1/4	1500 L/min	5~60°C		
					AF3000-03	PT3/8	1500 L/min	5~60°C		
					AF4000-04	PT1/2	4000 L/min	5~60°C		
					AF4000-06	PT3/4	6000 L/min	5~60°C		
					AF5000-06	PT3/4	7000 L/min	5~60°C		
					AF5000-10	PT1	7000 L/min	5~60°C		

AR系列调压阀 AR Series Regulator

Operating Pressure: 使用压力: 0~0.8Mpa	新款 New Type		老款 Old Type		型号 Model	螺纹尺寸 Port Size	额度流量 Rated Flow	使用温度 Operating Temperature	压力表 Pressure Gauge	说明 Notes
						AR1000-M5	M5	100 L/min	5~60°C	Y30-10-M5
					AR2000-02	PT1/4	550 L/min	5~60°C	Y40-10-1/8	
					AR3000-02	PT1/4	2000 L/min	5~60°C	Y40-10-1/8	
					AR3000-03	PT3/8	2500 L/min	5~60°C	Y40-10-1/8	
					AR4000-04	PT1/2	6000 L/min	5~60°C	Y50-10-1/4	
					AR4000-06	PT3/4	6000 L/min	5~60°C	Y50-10-1/4	
					AR5000-06	PT3/4	8000 L/min	5~60°C	Y50-10-1/4	
					AR5000-10	PT1	8000 L/min	5~60°C	Y50-10-1/4	

AL系列油雾器 AL Series Oil Lubricator

<p>Operating Pressure: 使用压力: 0~0.8Mpa</p>  <p>新款 New Type 老款 Old Type</p>	型号 Model	螺纹尺寸 Port Size	额定流量 Rated Flow	使用温度 Operating Temperature	建议用油 Recommended Oil	说明 Notes
	AL1000-M5	M5	110 L/min	5~60℃	ISO VG32 透平1号油	螺纹类型: -PT: PT螺纹 -NPT: NPT 螺纹 -G: G螺纹
	AL2000-02	PT1/4	750 L/min	5~60℃		
	AL3000-02	PT1/4	1500 L/min	5~60℃		
	AL3000-03	PT3/8	1500 L/min	5~60℃	ISO VG32 No.1 Turbine Oil	Thread Type: -PT: PT Thread -NPT: NPT Thread -G: G Thread
	AL4000-04	PT1/2	4000 L/min	5~60℃		
	AL4000-06	PT3/4	6000 L/min	5~60℃		
	AL5000-06	PT3/4	7000 L/min	5~60℃		
AL5000-10	PT1	7000 L/min	5~60℃			

QTY系列调压阀 QTY Series Regulator

<p>Operating Pressure: 使用压力: 0~0.8Mpa</p> 	型号 Model	螺纹尺寸 Port Size	额定流量 Rated Flow	使用温度 Operating Temperature	压力表 Pressure Gauge	本体材质 Body Material	说明 Notes
	QTY-08	G1/4	750L/min	-5~55℃	Y50-10-1/8	铝合金 Aluminium Alloy	螺纹类型: -PT: PT螺纹 -NPT: NPT 螺纹 -G: G螺纹
	QTY-10	G3/8	1800L/min	-5~55℃	Y50-10-1/8		
	QTY-15	G1/2	3000L/min	-5~55℃	Y50-10-1/8		
	QTY-20	G3/4	5000L/min	-5~55℃	Y50-10-1/8		Thread Type: -PT: PT Thread -NPT: NPT Thread -G: G Thread
	QTY-25	G1	7000L/min	-5~55℃	Y50-10-1/8		
	QTY-35	G1-1/4	9000L/min	-5~55℃	Y50-10-1/8		
	QTY-40	G1-1/2	11000L/min	-5~55℃	Y50-10-1/8		
QTY-40	G2	13000L/min	-5~55℃	Y50-10-1/8			

QTYH系列高压调压阀 QTYH Series High Pressure Regulator

<p>Operating Pressure: 使用压力: 0~3Mpa</p> 	型号 Model	螺纹尺寸 Port Size	使用温度 Operating Temperature	压力表 Pressure Gauge	本体材质 Body Material	说明 Notes
	QTYH-8	G1/4	-5~55℃	Y50-10-1/8	铝合金 Aluminium Alloy	螺纹类型: -PT: PT螺纹 -NPT: NPT 螺纹 -G: G螺纹
	QTYH-10	G3/8	-5~55℃	Y50-10-1/8		
	QTYH-15	G1/2	-5~55℃	Y50-10-1/8		
	QTYH-20	G3/4	-5~55℃	Y50-10-1/8		Thread Type: -PT: PT Thread -NPT: NPT Thread -G: G Thread
	QTYH-25	G1	-5~55℃	Y50-10-1/8		

QSL系列空气过滤器 QSL Series Filter

<p>Operating Pressure: 使用压力: 0~0.8Mpa</p> 	型号 Model	螺纹尺寸 Port Size	额定流量 Rated Flow	使用温度 Operating Temperature	过滤精度 Filtration	本体材质 Body Material	说明 Notes
	QSL-08	G1/4	750L/min	-5~55℃	40um	铝合金 Aluminium Alloy	螺纹类型: -PT: PT螺纹 -NPT: NPT 螺纹 -G: G螺纹
	QSL-10	G3/8	1800L/min	-5~55℃	40um		
	QSL-15	G1/2	3000L/min	-5~55℃	40um		
	QSL-20	G3/4	5000L/min	-5~55℃	40um		Thread Type: -PT: PT Thread -NPT: NPT Thread -G: G Thread
	QSL-25	G1	7000L/min	-5~55℃	40um		
	QSL-35	G1-1/4	9000L/min	-5~55℃	40um		
	QSL-40	G1-1/2	11000L/min	-5~55℃	40um		
QSL-50	G2	13000L/min	-5~55℃	40um			

QIU系列油雾器 QIU Series Oil Lubricator

<p>Operating Pressure: 使用压力: 0~0.8Mpa</p> 	型号 Model	螺纹尺寸 Port Size	额定流量 Rated Flow	使用温度 Operating Temperature	建议用油 Recommended Oil	本体材质 Body Material	说明 Notes
	QIU-08	G1/4	750L/min	-5~55℃	ISO VG32 透平1号油 ISO VG32 No.1 Turbine Oil	铝合金 Aluminium Alloy	螺纹类型: -PT: PT螺纹 -NPT: NPT 螺纹 -G: G螺纹
	QIU-10	G3/8	1800L/min	-5~55℃			
	QIU-15	G1/2	3000L/min	-5~55℃	建议使用本公司有雾器 专用油 Recommend to use Our Company Oil		
	QIU-20	G3/4	5000L/min	-5~55℃			
	QIU-25	G1	7000L/min	-5~55℃			
	QIU-35	G1-1/4	9000L/min	-5~55℃			
	QIU-40	G1-1/2	11000L/min	-5~55℃			
QIU-50	G2	13000L/min	-5~55℃		Thread Type: -PT: PT Thread -NPT: NPT Thread -G: G Thread		

A/B系列F.R.L三联件 A/B Series F.R.L Three Units

Operating Pressure: 使用压力:0~0.8Mpa	型号 Model	螺纹尺寸 Port Size	额定流量 Rated Flow	压力表 Pressure Gauge	使用温度 Operating Temperature	排水类型 Drain Type	说明 Notes
 新款 New Type	 老款 Old Type	AC1500	PT1/8	650L/min	Y40-10-1/8	5~60℃	排水类型: -空白:差压排水 -M:手动排水 -A:自动排水 Thread Type: -PT: PT Thread -NPT: NPT Thread -G: G Thread
		AC2000	PT1/4	750L/min	Y40-10-1/8	5~60℃	
		BC2000	PT1/4	1000L/min	Y50-10-1/4	5~60℃	
		BC3000	PT3/8	1500L/min	Y50-10-1/4	5~60℃	
		BC4000	PT1/2	3000L/min	Y50-10-1/4	5~60℃	

A/B系列F.R.L二联件 A/B Series F.R.L Two Units

Operating Pressure: 使用压力:0~0.8Mpa	型号 Model	螺纹尺寸 Port Size	额定流量 Rated Flow	压力表 Pressure Gauge	使用温度 Operating Temperature	排水类型 Drain Type	说明 Notes
 新款 New Type	 老款 Old Type	AFC1500	PT1/8	650L/min	Y40-10-1/8	5~60℃	排水类型: -空白:差压排水 -M:手动排水 -A:自动排水 Thread Type: -PT: PT Thread -NPT: NPT Thread -G: G Thread
		AFC2000	PT1/4	750L/min	Y40-10-1/8	5~60℃	
		BFC2000	PT1/4	1000L/min	Y50-10-1/4	5~60℃	
		BFC3000	PT3/8	1500L/min	Y50-10-1/4	5~60℃	
		BFC4000	PT1/2	3000L/min	Y50-10-1/4	5~60℃	

A/B系列调压过滤器 A/B Series Filter & Regulator

Operating Pressure: 使用压力:0~0.8Mpa	型号 Model	螺纹尺寸 Port Size	额定流量 Rated Flow	压力表 Pressure Gauge	使用温度 Operating Temperature	排水类型 Drain Type	说明 Notes
 新款 New Type	 老款 Old Type	AFR1500	PT1/8	650L/min	Y40-10-1/8	5~60℃	排水类型: -空白:差压排水 -M:手动排水 -A:自动排水 Thread Type: -PT: PT Thread -NPT: NPT Thread -G: G Thread
		AFR2000	PT1/4	750L/min	Y40-10-1/8	5~60℃	
		BFR2000	PT1/4	1000L/min	Y50-10-1/4	5~60℃	
		BFR3000	PT3/8	1500L/min	Y50-10-1/4	5~60℃	
		BFR4000	PT1/2	3000L/min	Y50-10-1/4	5~60℃	

A/B系列空气过滤器 A/B Series Filter

Operating Pressure: 使用压力:0~0.8Mpa	型号 Model	螺纹尺寸 Port Size	额定流量 Rated Flow	使用温度 Operating Temperature	排水类型 Drain Type	说明 Notes
 新款 New Type	 老款 Old Type	AF1500	PT1/8	650L/min	5~60℃	排水类型: -空白:差压排水 -M:手动排水 -A:自动排水 Thread Type: -PT: PT Thread -NPT: NPT Thread -G: G Thread
		AF2000	PT1/4	750L/min	5~60℃	
		BF2000	PT1/4	1000L/min	5~60℃	
		BF3000	PT3/8	1500L/min	5~60℃	
		BF4000	PT1/2	3000L/min	5~60℃	

A/B系列调压阀 A/B Series Regulator

Operating Pressure: 使用压力:0~0.8Mpa	型号 Model	螺纹尺寸 Port Size	额定流量 Rated Flow	压力表 Pressure Gauge	使用温度 Operating Temperature	说明 Notes	
							新款 New Type
 新款 New Type	 老款 Old Type	AR1500	PT1/8	650L/min	Y40-10-1/8	螺纹类型: -PT: PT 螺纹 -NPT: NPT 螺纹 -G: G 螺纹 Thread Type: -PT: PT Thread -NPT: NPT Thread -G: G Thread	
		AR2000	PT1/4	750L/min	Y40-10-1/8		5~60℃
		BR1500	PT1/8	750L/min	Y40-10-1/8		5~60℃
		BR2000	PT1/4	1000L/min	Y50-10-1/4		5~60℃
		BR3000	PT3/8	1500L/min	Y50-10-1/4		5~60℃
		BR4000	PT1/2	3000L/min	Y50-10-1/4		5~60℃

A/B系列油雾器 A/B Series Oil Lubricator

Operating Pressure: 使用压力:0~0.8Mpa	型号 Model	螺纹尺寸 Port Size	额定流量 Rated Flow	使用温度 Operating Temperature	建议用油 Recommended Oil	说明 Notes	
							新款 New Type
 新款 New Type	 老款 Old Type	AL1500	PT1/8	650L/min	ISO VG32 透平1号油 ISO VG32 No.1 Turbine Oil	螺纹类型: -PT: PT 螺纹 -NPT: NPT 螺纹 -G: G 螺纹 Thread Type: -PT: PT Thread -NPT: NPT Thread -G: G Thread	
		AL2000	PT1/4	750L/min			5~60℃
		BL2000	PT1/4	1000L/min			5~60℃
		BL3000	PT3/8	1500L/min			5~60℃
		BL4000	PT1/2	3000L/min			5~60℃

GC系列F.R.L三联件 GC Series F.R.L Three Units

Operating Pressure: 使用压力:0~0.8Mpa 	型号 Model	螺纹尺寸 Port size	过滤精度 Filtration	使用温度 Operating Temperature	排水类型 Drain Type	说明 Notes
	GC200-06/08	PT1/8 * PT1/4	40um	5~60℃	排水类型: -空白: 差压排水 -M: 手动排水 -A: 自动排水 Drain Type: -Blank: Pressure Drain -M: Manual Drain -A: Automatic Drain	螺纹类型: -PT: PT螺纹 -NPT: NPT 螺纹 -G: G螺纹 Thread Type: -PT: PT Thread -NPT: NPT Thread -G: G Thread
	GC300-08/10/15	PT1/4 * PT3/8 * PT1/2	40um	5~60℃		
	GC300-10/15	PT3/8 * PT1/2	40um	5~60℃		
	GC400-10/15	PT3/8 * PT1/2	40um	5~60℃		
	GC600-20/25	PT3/4 * PT1"	40um	5~60℃		

GFC系列F.R.L二联件 GFC Series F.R.L Two Units

Operating Pressure: 使用压力:0~0.8Mpa 	型号 Model	螺纹尺寸 Port Size	过滤精度 Filtration	使用温度 Operating Temperature	排水类型 Drain Type	说明 Notes
	GFC200-06/08	PT1/8 * PT1/4	40um	5~60℃	排水类型: -空白: 差压排水 -M: 手动排水 -A: 自动排水 Drain Type: -Blank: Pressure Drain -M: Manual Drain -A: Automatic Drain	螺纹类型: -PT: PT螺纹 -NPT: NPT 螺纹 -G: G螺纹 Thread Type: -PT: PT Thread -NPT: NPT Thread -G: G Thread
	GFC300-08/10/15	PT1/4 * PT3/8 * PT1/2	40um	5~60℃		
	GFC300-10/15	PT3/8 * PT1/2	40um	5~60℃		
	GFC400-10/15	PT3/8 * PT1/2	40um	5~60℃		
	GFC600-20/25	PT3/4 * PT1"	40um	5~60℃		

GFR系列调压过滤器 GFR Series Filter & Regulator

Operating Pressure: 使用压力:0~0.8Mpa 	型号 Model	螺纹尺寸 Port Size	过滤精度 Filtration	使用温度 Operating Temperature	排水类型 Drain Type	说明 Notes
	GFR200-06/08	PT1/8 * PT1/4	40um	5~60℃	排水类型: -空白: 差压排水 -M: 手动排水 -A: 自动排水 Drain Type: -Blank: Pressure Drain -M: Manual Drain -A: Automatic Drain	螺纹类型: -PT: PT螺纹 -NPT: NPT 螺纹 -G: G螺纹 Thread Type: -PT: PT Thread -NPT: NPT Thread -G: G Thread
	GFR300-08/10/15	PT1/4 * PT3/8 * PT1/2	40um	5~60℃		
	GFR300-10/15	PT3/8 * PT1/2	40um	5~60℃		
	GFR400-10/15	PT3/8 * PT1/2	40um	5~60℃		
	GFR600-20/25	PT3/4 * PT1"	40um	5~60℃		

GF系列空气过滤器 GF Series Filter

Operating Pressure: 使用压力:0~0.8Mpa 	型号 Model	螺纹尺寸 Port Size	过滤精度 Filtration	使用温度 Operating Temperature	排水类型 Drain Type	说明 Notes
	GF200-06/08	PT1/8 * PT1/4	40um	5~60℃	排水类型: -空白: 差压排水 -M: 手动排水 -A: 自动排水 Drain Type: -Blank: Pressure Drain -M: Manual Drain -A: Automatic Drain	螺纹类型: -PT: PT螺纹 -NPT: NPT 螺纹 -G: G螺纹 Thread Type: -PT: PT Thread -NPT: NPT Thread -G: G Thread
	GF300-08/10/15	PT1/4 * PT3/8 * PT1/2	40um	5~60℃		
	GF300-10/15	PT3/8 * PT1/2	40um	5~60℃		
	GF400-10/15	PT3/8 * PT1/2	40um	5~60℃		
	GF600-20/25	PT3/4 * PT1"	40um	5~60℃		

GR系列调压阀 GR Series Regulator

Operating Pressure: 使用压力:0~0.8Mpa 	型号 Model	螺纹尺寸 Port Size	过滤精度 Filtration	使用温度 Operating Temperature	压力表 Pressure Gauge	说明 Notes
	GR200-06/08	PT1/8 * PT1/4	40um	5~60℃	1:MPa 2:Psi 3:Bar 4:Kg/cm ²	螺纹类型: -PT: PT螺纹 -NPT: NPT 螺纹 -G: G螺纹 Thread Type: -PT: PT Thread -NPT: NPT Thread -G: G Thread
	GR300-08/10/15	PT1/4 * PT3/8 * PT1/2	40um	5~60℃		
	GR300-10/15	PT3/8 * PT1/2	40um	5~60℃		
	GR400-10/15	PT3/8 * PT1/2	40um	5~60℃		
	GR600-20/25	PT3/4 * PT1"	40um	5~60℃		

GL系列油雾器 GL Series Lubricator

Operating Pressure: 使用压力:0~0.8Mpa 	型号 Model	螺纹尺寸 Port Size	过滤精度 Filtration	使用温度 Operating Temperature	建议用油 Recommended Oil	说明 Notes
	GL200-06/08	PT1/8 * PT1/4	40um	5~60℃	ISO VG32 透平1号油	螺纹类型: -PT: PT螺纹 -NPT: NPT 螺纹 -G: G螺纹
	GL300-08/10/15	PT1/4 * PT3/8 * PT1/2	40um	5~60℃		
	GL300-10/15	PT3/8 * PT1/2	40um	5~60℃	ISO VG32 No.1 Turbine Oil	Thread Type: -PT: PT Thread -NPT: NPT Thread -G: G Thread
	GL400-10/15	PT3/8 * PT1/2	40um	5~60℃		
	GL600-20/25	PT3/4 * PT1"	40um	5~60℃		

FOU系列F.R.L三联件 FOU Series F.R.L Three Units

Operating Pressure: 使用压力:0~0.8Mpa 	型号 Model	螺纹尺寸 Port Size	过滤精度 Filtration	使用温度 Operating Temperature	说明 Notes
	FOU(MINI)-01/02/03	G1/8*G1/4*G3/8	40 μm	5~60℃	螺纹类型: -PT: PT螺纹 -NPT: NPT 螺纹 -G: G螺纹
	FOU(MIDI)-02/03/04/06	G1/4*G3/8*G1/2*G3/4	40 μm	5~60℃	
FOU(MAXII)-04/06/08	G1/2*G3/4*G1	40 μm	5~60℃	Thread Type: -PT: PT Thread -NPT: NPT Thread -G: G Thread	

FRC系列F.R.L二连件 FRC Series F.R.L Two Units

Operating Pressure: 使用压力:0~0.8Mpa 	型号 Model	螺纹尺寸 Port Size	过滤精度 Filtration	使用温度 Operating Temperature	说明 Notes
	FRC(MINI)-01/02/03	G1/8*G1/4*G3/8	40 μm	5~60℃	螺纹类型: -PT: PT螺纹 -NPT: NPT 螺纹 -G: G螺纹
	FRC(MIDI)-02/03/04/06	G1/4*G3/8*G1/2*G3/4	40 μm	5~60℃	
FRC(MAXII)-04/06/08	G1/2*G3/4*G1	40 μm	5~60℃	Thread Type: -PT: PT Thread -NPT: NPT Thread -G: G Thread	

LFR系列调压过滤器 LFR Series Filter & Regulator

Operating Pressure: 使用压力:0~0.8Mpa 	型号 Model	螺纹尺寸 Port Size	过滤精度 Filtration	使用温度 Operating Temperature	说明 Notes
	LFR(MINI)-01/02/03	G1/8*G1/4*G3/8	40 μm	5~60℃	螺纹类型: -PT: PT螺纹 -NPT: NPT 螺纹 -G: G螺纹
	LFR(MIDI)-02/03/04/06	G1/4*G3/8*G1/2*G3/4	40 μm	5~60℃	
LFR(MAXII)-04/06/08	G1/2*G3/4*G1	40 μm	5~60℃	Thread Type: -PT: PT Thread -NPT: NPT Thread -G: G Thread	

LF系列空气过滤器 LF Series Filter

Operating Pressure: 使用压力:0~0.8Mpa 	型号 Model	螺纹尺寸 Port Size	过滤精度 Filtration	使用温度 Operating Temperature	说明 Notes
	LF(MINI)-01/02/03	G1/8*G1/4*G3/8	40 μm	5~60℃	螺纹类型: -PT: PT螺纹 -NPT: NPT 螺纹 -G: G螺纹
	LF(MIDI)-02/03/04/06	G1/4*G3/8*G1/2*G3/4	40 μm	5~60℃	
LF(MAXII)-04/06/08	G1/2*G3/4*G1	40 μm	5~60℃	Thread Type: -PT: PT Thread -NPT: NPT Thread -G: G Thread	

LR系列调压阀 LR Series Regulator

Operating Pressure: 使用压力:0~0.8Mpa 	型号 Model	螺纹尺寸 Port Size	过滤精度 Filtration	使用温度 Operating Temperature	说明 Notes
	LR(MINI)-01/02/03	G1/8*G1/4*G3/8	40 μm	5~60℃	螺纹类型: -PT: PT螺纹 -NPT: NPT 螺纹 -G: G螺纹
	LR(MIDI)-02/03/04/06	G1/4*G3/8*G1/2*G3/4	40 μm	5~60℃	
LR(MAXII)-04/06/08	G1/2*G3/4*G1	40 μm	5~60℃	Thread Type: -PT: PT Thread -NPT: NPT Thread -G: G Thread	

LOE系列油雾器 LOE Series Oil Lubricator

Operating Pressure: 使用压力:0~0.8Mpa 	型号 Model	螺纹尺寸 Port Size	使用温度 Operating Temperature	建议用油 Recommended Oil	说明 Notes
	LOE(MINI)-01/02/03	G1/8*G1/4*G3/8	5~60℃	ISO VG32 透平1号油	螺纹类型: -PT: PT螺纹 -NPT: NPT 螺纹 -G: G螺纹
	LOE(MIDI)-02/03/04/06	G1/4*G3/8*G1/2*G3/4	5~60℃		
LOE(MAXII)-04/06/08	G1/2*G3/4*G1	5~60℃	ISO VG32 No.1 Turbine Oil	Thread Type: -PT: PT Thread -NPT: NPT Thread -G: G Thread	

UFRL系列F.R.L三联件 URLF Series F.R.L Three Units

Operating Pressure: 使用压力:0~0.8Mpa 	型号 Model	螺纹尺寸 Port Size	额定流量 Rated Flow	过滤精度 Filtration	使用温度 Operating Temperature	说明 Notes
	UFRL-02	G1/4	2080L/min	40 μm	5~60℃	螺纹类型: -PT: PT螺纹 -NPT: NPT 螺纹 -G: G螺纹
	UFRL-03	G3/8	2100L/min	40 μm	5~60℃	
	UFRL-04	G1/2	2600L/min	40 μm	5~60℃	
	UFRL-06	G3/4	7940L/min	40 μm	5~60℃	Thread Type: -PT: PT Thread -NPT: NPT Thread -G: G Thread
UFRL-08	G1	8200L/min	40 μm	5~60℃		

UFR/L系列F.R.L二联件 UFR/L Series F.R.L Two Units

Operating Pressure: 使用压力:0~0.8Mpa 	型号 Model	螺纹尺寸 Port Size	额定流量 Rated Flow	过滤精度 Filtration	使用温度 Operating Temperature	说明 Notes
	UFR/L-02	G1/4	2080L/min	40 μm	5~60℃	螺纹类型: -PT: PT螺纹 -NPT: NPT 螺纹 -G: G螺纹
	UFR/L-03	G3/8	2100L/min	40 μm	5~60℃	
	UFR/L-04	G1/2	2600L/min	40 μm	5~60℃	
	UFR/L-06	G3/4	7940L/min	40 μm	5~60℃	Thread Type: -PT: PT Thread -NPT: NPT Thread -G: G Thread
UFR/L-08	G1	8200L/min	40 μm	5~60℃		

UFR系列调压过滤器 UFR Series Filter & Regulator

Operating Pressure: 使用压力:0~0.8Mpa 	型号 Model	螺纹尺寸 Port Size	额定流量 Rated Flow	过滤精度 Filtration	使用温度 Operating Temperature	说明 Notes
	UFR-02	G1/4	2080L/min	40 μm	5~60℃	螺纹类型: -PT: PT螺纹 -NPT: NPT 螺纹 -G: G螺纹
	UFR-03	G3/8	2100L/min	40 μm	5~60℃	
	UFR-04	G1/2	2600L/min	40 μm	5~60℃	
	UFR-06	G3/4	7940L/min	40 μm	5~60℃	Thread Type: -PT: PT Thread -NPT: NPT Thread -G: G Thread
UFR-08	G1	8200L/min	40 μm	5~60℃		

UF系列空气过滤器 UF Series Filter

Operating Pressure: 使用压力:0~0.8Mpa 	型号 Model	螺纹尺寸 Port Size	额定流量 Rated Flow	过滤精度 Filtration	使用温度 Operating Temperature	说明 Notes
	UF-02	G1/4	2080L/min	40 μm	5~60℃	螺纹类型: -PT: PT螺纹 -NPT: NPT 螺纹 -G: G螺纹
	UF-03	G3/8	2100L/min	40 μm	5~60℃	
	UF-04	G1/2	2600L/min	40 μm	5~60℃	
	UF-06	G3/4	7940L/min	40 μm	5~60℃	Thread Type: -PT: PT Thread -NPT: NPT Thread -G: G Thread
UF-08	G1	8200L/min	40 μm	5~60℃		

UR系列调压阀 UR Series Regulator

Operating Pressure: 使用压力:0~0.8Mpa 	型号 Model	螺纹尺寸 Port Size	额定流量 Rated Flow	过滤精度 Filtration	使用温度 Operating Temperature	说明 Notes
	UR-02	G1/4	2080L/min	40 μm	5~60℃	螺纹类型: -PT: PT螺纹 -NPT: NPT 螺纹 -G: G螺纹
	UR-03	G3/8	2100L/min	40 μm	5~60℃	
	UR-04	G1/2	2600L/min	40 μm	5~60℃	
	UR-06	G3/4	7940L/min	40 μm	5~60℃	Thread Type: -PT: PT Thread -NPT: NPT Thread -G: G Thread
UR-08	G1	8200L/min	40 μm	5~60℃		

UL系列油雾器 UL Series Oil Lubricator

Operating Pressure: 使用压力:0~0.8Mpa 	型号 Model	螺纹尺寸 Port Size	额定流量 Rated Flow	过滤精度 Filtration	使用温度 Operating Temperature	说明 Notes
	UL-02	G1/4	2080L/min	40 μm	5~60℃	螺纹类型: -PT: PT螺纹 -NPT: NPT 螺纹 -G: G螺纹
	UL-03	G3/8	2100L/min	40 μm	5~60℃	
	UL-04	G1/2	2600L/min	40 μm	5~60℃	
	UL-06	G3/4	7940L/min	40 μm	5~60℃	Thread Type: -PT: PT Thread -NPT: NPT Thread -G: G Thread
UL-08	G1	8200L/min	40 μm	5~60℃		

C系列F.R.L三联件 C Series F.R.L Three Units

Operating Pressure: 使用压力:0~0.8Mpa 	型号 Model	螺纹尺寸 Port Size	过滤精度 Filtration	使用温度 Operating Temperature	说明 Notes
	C1000-01/02	PT1/8*PT1/4	40 μm	5~60℃	螺纹类型: -PT: PT螺纹 -NPT: NPT 螺纹 -G: G螺纹
	C2000-02/03	PT1/4*PT3/8	40 μm	5~60℃	
	C3000-02/03	PT1/4*PT3/8	40 μm	5~60℃	
	C4000-02/03/04	PT1/4*PT3/8*PT1/2	40 μm	5~60℃	Thread Type: -PT: PT Thread -NPT: NPT Thread -G: G Thread
	C8000-06/10	PT3/4*PT1	40 μm	5~60℃	

C系列F.R.L二联件 C Series F.R.L Two Units

Operating Pressure: 使用压力:0~0.8Mpa 	型号 Model	螺纹尺寸 Port Size	过滤精度 Filtration	使用温度 Operating Temperature	说明 Notes
	C1010-01/02	PT1/8*PT1/4	40 μm	5~60℃	螺纹类型: -PT: PT螺纹 -NPT: NPT 螺纹 -G: G螺纹
	C2010-02/03	PT1/4*PT3/8	40 μm	5~60℃	
	C3010-02/03	PT1/4*PT3/8	40 μm	5~60℃	
	C4010-02/03/04	PT1/4*PT3/8*PT1/2	40 μm	5~60℃	Thread Type: -PT: PT Thread -NPT: NPT Thread -G: G Thread
	C8010-06/10	PT3/4*PT1	40 μm	5~60℃	

W系列调压过滤器 W Series Filter & Regulator

Operating Pressure: 使用压力:0~0.8Mpa 	型号 Model	螺纹尺寸 Port Size	过滤精度 Filtration	使用温度 Operating Temperature	说明 Notes
	W1000-01/02	PT1/8*PT1/4	40 μm	5~60℃	螺纹类型: -PT: PT螺纹 -NPT: NPT 螺纹 -G: G螺纹
	W2000-02/03	PT1/4*PT3/8	40 μm	5~60℃	
	W3000-02/03	PT1/4*PT3/8	40 μm	5~60℃	
	W4000-02/03/04	PT1/4*PT3/8*PT1/2	40 μm	5~60℃	Thread Type: -PT: PT Thread -NPT: NPT Thread -G: G Thread
	W8000-06/10	PT3/4*PT1	40 μm	5~60℃	

F系列空气过滤器 F Series Filter

Operating Pressure: 使用压力:0~0.8Mpa 	型号 Model	螺纹尺寸 Port Size	过滤精度 Filtration	使用温度 Operating Temperature	说明 Notes
	F1000-01/02	PT1/8*PT1/4	40 μm	5~60℃	螺纹类型: -PT: PT螺纹 -NPT: NPT 螺纹 -G: G螺纹
	F2000-02/03	PT1/4*PT3/8	40 μm	5~60℃	
	F3000-02/03	PT1/4*PT3/8	40 μm	5~60℃	
	F4000-02/03/04	PT1/4*PT3/8*PT1/2	40 μm	5~60℃	Thread Type: -PT: PT Thread -NPT: NPT Thread -G: G Thread
	F8000-06/10	PT3/4*PT1	40 μm	5~60℃	

R系列调压阀 R Series Regulator

Operating Pressure: 使用压力:0~0.8Mpa 	型号 Model	螺纹尺寸 Port Size	过滤精度 Filtration	使用温度 Operating Temperature	说明 Notes
	R1000-01/02	PT1/8*PT1/4	40 μm	5~60℃	螺纹类型: -PT: PT螺纹 -NPT: NPT 螺纹 -G: G螺纹
	R2000-02/03	PT1/4*PT3/8	40 μm	5~60℃	
	R3000-02/03	PT1/4*PT3/8	40 μm	5~60℃	
	R4000-02/03/04	PT1/4*PT3/8*PT1/2	40 μm	5~60℃	Thread Type: -PT: PT Thread -NPT: NPT Thread -G: G Thread
	R8000-06/10	PT3/4*PT1	40 μm	5~60℃	

L系列油雾器 L Series Oil Lubricator

Operating Pressure: 使用压力:0~0.8Mpa 	型号 Model	螺纹尺寸 Port Size	过滤精度 Filtration	使用温度 Operating Temperature	说明 Notes
	L1000-01/02	PT1/8*PT1/4	40 μm	5~60℃	螺纹类型: -PT: PT螺纹 -NPT: NPT 螺纹 -G: G螺纹
	L2000-02/03	PT1/4*PT3/8	40 μm	5~60℃	
	L3000-02/03	PT1/4*PT3/8	40 μm	5~60℃	
	L4000-02/03/04	PT1/4*PT3/8*PT1/2	40 μm	5~60℃	Thread Type: -PT: PT Thread -NPT: NPT Thread -G: G Thread
	L8000-06/10	PT3/4*PT1	40 μm	5~60℃	

39系列F.R.L三联件 39 Series F.R.L Three Units

Operating Pressure: 使用压力:0~0.8Mpa 	型号 Model	螺纹尺寸 Port Size	过滤精度 Filtration	使用温度 Operating Temperature	说明 Notes
	398-6	PT1/8	40 μm	5~60°C	螺纹类型: -PT: PT螺纹 -NPT: NPT 螺纹 -G: G螺纹
	398-8	PT1/4	40 μm	5~60°C	
	398-10	PT3/8	40 μm	5~60°C	
	398-15	PT1/2	40 μm	5~60°C	Thread Type: -PT: PT Thread -NPT: NPT Thread -G: G Thread
398-20/25	PT3/4*PT1	40 μm	5~60°C		

39系列F.R.L二联件 39 Series F.R.L Two Units

Operating Pressure: 使用压力:0~0.8Mpa 	型号 Model	螺纹尺寸 Port Size	过滤精度 Filtration	使用温度 Operating Temperature	说明 Notes
	399-6	PT1/8	40 μm	5~60°C	螺纹类型: -PT: PT螺纹 -NPT: NPT 螺纹 -G: G螺纹
	399-8	PT1/4	40 μm	5~60°C	
	399-10	PT3/8	40 μm	5~60°C	
	399-15	PT1/2	40 μm	5~60°C	Thread Type: -PT: PT Thread -NPT: NPT Thread -G: G Thread
399-20/25	PT3/4*PT1	40 μm	5~60°C		

39系列调压过滤器 39 Series Filter & Regulator

Operating Pressure: 使用压力:0~0.8Mpa 	型号 Model	螺纹尺寸 Port Size	过滤精度 Filtration	使用温度 Operating Temperature	说明 Notes
	397-6	PT1/8	40 μm	5~60°C	螺纹类型: -PT: PT螺纹 -NPT: NPT 螺纹 -G: G螺纹
	397-8	PT1/4	40 μm	5~60°C	
	397-10	PT3/8	40 μm	5~60°C	
	397-15	PT1/2	40 μm	5~60°C	Thread Type: -PT: PT Thread -NPT: NPT Thread -G: G Thread
397-20/25	PT3/4*PT1	40 μm	5~60°C		

39系列空气过滤器 39 Series Filter

Operating Pressure: 使用压力:0~0.8Mpa 	型号 Model	螺纹尺寸 Port Size	过滤精度 Filtration	使用温度 Operating Temperature	说明 Notes
	396-6	PT1/8	40 μm	5~60°C	螺纹类型: -PT: PT螺纹 -NPT: NPT 螺纹 -G: G螺纹
	396-8	PT1/4	40 μm	5~60°C	
	396-10	PT3/8	40 μm	5~60°C	
	396-15	PT1/2	40 μm	5~60°C	Thread Type: -PT: PT Thread -NPT: NPT Thread -G: G Thread
396-20/25	PT3/4*PT1	40 μm	5~60°C		

39系列调压阀 39 Series Regulator

Operating Pressure: 使用压力:0~0.8Mpa 	型号 Model	螺纹尺寸 Port Size	过滤精度 Filtration	使用温度 Operating Temperature	说明 Notes
	395-6	PT1/8	40 μm	5~60°C	螺纹类型: -PT: PT螺纹 -NPT: NPT 螺纹 -G: G螺纹
	395-8	PT1/4	40 μm	5~60°C	
	395-10	PT3/8	40 μm	5~60°C	
	395-15	PT1/2	40 μm	5~60°C	Thread Type: -PT: PT Thread -NPT: NPT Thread -G: G Thread
395-20/25	PT3/4*PT1	40 μm	5~60°C		

39系列油雾器 39 Series Oil Lubricator

Operating Pressure: 使用压力:0~0.8Mpa 	型号 Model	螺纹尺寸 Port Size	过滤精度 Filtration	使用温度 Operating Temperature	说明 Notes
	394-6	PT1/8	40 μm	5~60°C	螺纹类型: -PT: PT螺纹 -NPT: NPT 螺纹 -G: G螺纹
	394-8	PT1/4	40 μm	5~60°C	
	394-10	PT3/8	40 μm	5~60°C	
	394-15	PT1/2	40 μm	5~60°C	Thread Type: -PT: PT Thread -NPT: NPT Thread -G: G Thread
394-20/25	PT3/4*PT1	40 μm	5~60°C		

SFC系列F.R.L二联件 SFC Series F.R.L Two Units

Operating Pressure: 使用压力: 0~0.8Mpa 	型号 Model	螺纹尺寸 Port Size	额定流量 Rated Flow	过滤精度 Filtration	压力表 Pressure Gauge	使用温度 Operating Temperature	说明 Notes
	SFC200	PT1/4	1700L/min	20um	Y50-10-1/8	5~60℃	螺纹类型: -PT: PT螺纹 -NPT: NPT 螺纹 -G: G螺纹 Thread Type: -PT: PT Thread -NPT: NPT Thread -G: G Thread
	SFC300	PT3/8	2300L/min	20um	Y50-10-1/8	5~60℃	
	SFC400	PT1/2	3000L/min	20um	Y50-10-1/8	5~60℃	

SFR系列调压过滤器 SFR Series Filter & Regulator

Operating Pressure: 使用压力: 0~0.8Mpa 	型号 Model	螺纹尺寸 Port Size	额定流量 Rated Flow	过滤精度 Filtration	压力表 Pressure Gauge	使用温度 Operating Temperature	说明 Notes
	SFR200	PT1/4	2000L/min	20um	Y50-10-1/8	5~60℃	螺纹类型: -PT: PT螺纹 -NPT: NPT 螺纹 -G: G螺纹 Thread Type: -PT: PT Thread -NPT: NPT Thread -G: G Thread
	SFR300	PT3/8	3000L/min	20um	Y50-10-1/8	5~60℃	
	SFR400	PT1/2	4000L/min	20um	Y50-10-1/8	5~60℃	

SL系列油雾器 SL Series Oil Lubricator

Operating Pressure: 使用压力: 0~0.8Mpa 	型号 Model	螺纹尺寸 Port Size	额定流量 Rated Flow	建议用油 Recommended Oil	使用温度 Operating Temperature	说明 Notes
	SL200	PT1/4	1500L/min	ISO VG32 透平1号油 ISO VG32 No.1 Turbine Oil	5~60℃	螺纹类型: -PT: PT螺纹 -NPT: NPT 螺纹 -G: G螺纹 Thread Type: -PT: PT Thread -NPT: NPT Thread -G: G Thread
	SL300	PT3/8	2300L/min			
	SL400	PT1/2	4000L/min			

MC系列F.R.L二联件 MC Series F.R.L Two Units

Operating Pressure: 使用压力: 0~0.8Mpa 	型号 Model	螺纹尺寸 Port Size	过滤精度 Filtration	使用温度 Operating Temperature	说明 Notes
	MC104-C	G1/4	25um	5~60℃	螺纹类型: -PT: PT螺纹 -NPT: NPT 螺纹 -G: G螺纹 Thread Type: -PT: PT Thread -NPT: NPT Thread -G: G Thread
	MC238-C	G3/8	25um		
	MC202-C	G1/2	25um		
	MC401-C	G1	25um		

MC系列调压过滤器 MC Series Filter & Regulator

Operating Pressure: 使用压力: 0~0.8Mpa 	型号 Model	螺纹尺寸 Port Size	过滤精度 Filtration	使用温度 Operating Temperature	说明 Notes
	MC104-D	G1/4	25um	5~60℃	螺纹类型: -PT: PT螺纹 -NPT: NPT 螺纹 -G: G螺纹 Thread Type: -PT: PT Thread -NPT: NPT Thread -G: G Thread
	MC238-D	G3/8	25um		
	MC202-D	G1/2	25um		
	MC401-D	G1	25um		

MC系列油雾器 MC Series Oil Lubricator

Operating Pressure: 使用压力: 0~0.8Mpa 	型号 Model	螺纹尺寸 Port Size	使用温度 Operating Temperature	建议用油 Recommended Oil	说明 Notes
	MC104-L	G1/4	5~60℃	ISO VG32 透平1号油 ISO VG32 No.1 Turbine Oil	螺纹类型: -PT: PT螺纹 -NPT: NPT 螺纹 -G: G螺纹 Thread Type: -PT: PT Thread -NPT: NPT Thread -G: G Thread
	MC238-L	G3/8			
	MC202-L	G1/2			
	MC401-L	G1			

MC系列过滤器 MC Series Filter

Operating Pressure: 使用压力: 0~0.8Mpa 	型号 Model	螺纹尺寸 Port Size	过滤精度 Filtration	使用温度 Operating Temperature	说明 Notes
	MC104-F	G1/4	25um	5~60℃	螺纹类型: -PT: PT螺纹 -NPT: NPT 螺纹 -G: G螺纹 Thread Type: -PT: PT Thread -NPT: NPT Thread -G: G Thread
	MC238-F	G3/8	25um	5~60℃	
	MC202-F	G1/2	25um	5~60℃	
MC401-F	G1	25um	5~60℃		

QSLH系列高压调压阀 QSLH Series High Pressure Regulator

Operating Pressure: 使用压力: 0~0.8Mpa 	型号 Model	螺纹尺寸 Port Size	过滤精度 Filtration	使用温度 Operating Temperature	说明 Notes
	QSLH-8	G1/4	25um	5~60℃	螺纹类型: -PT: PT螺纹 -NPT: NPT 螺纹 -G: G螺纹 Thread Type: -PT: PT Thread -NPT: NPT Thread -G: G Thread
	QSLH-10	G3/8	25um	5~60℃	
	QSLH-15	G1/2	25um	5~60℃	
QSLH-25	G1	25um	5~60℃		

QLFH系列高压过滤器 QFLH Series High Pressure Filter

Operating Pressure: 使用压力: 0~3.5Mpa 	型号 Model	螺纹尺寸 Port Size	使用温度 Operating Temperature	过滤精度 Filtration	本体材质 Body Material	说明 Notes
	QLFH-08	G1/4	5~80℃	40um	铝合金 Aluminium Alloy	螺纹类型: -PT: PT螺纹 -NPT: NPT 螺纹 -G: G螺纹 Thread Type: -PT: PT Thread -NPT: NPT Thread -G: G Thread
	QLFH-10	G3/8	5~80℃	40um		
	QLFH-15	G1/2	5~80℃	40um		
	QLFH-20	G3/4	5~80℃	40um		
QLFH-25	G1	5~80℃	40um			

QFRH系列高压调压过滤器 QFRH Series High Pressure Filter & Regulator

Operating Pressure: 使用压力: 0~3.5Mpa 	型号 Model	螺纹尺寸 Port Size	使用温度 Operating Temperature	过滤精度 Filtration	本体材质 Body Material	说明 Notes
	QFRH-08	G1/4	5~80℃	40um	铝合金 Aluminium Alloy	螺纹类型: -PT: PT螺纹 -NPT: NPT 螺纹 -G: G螺纹 Thread Type: -PT: PT Thread -NPT: NPT Thread -G: G Thread
	QFRH-10	G3/8	5~80℃	40um		
	QFRH-15	G1/2	5~80℃	40um		
	QFRH-20	G3/4	5~80℃	40um		
QFRH-25	G1	5~80℃	40um			

AD系列末端自动排水器 AD Series Auto Drainer

Operating Pressure: 使用压力: 0~0.8Mpa 	型号 Model	螺纹尺寸 Port Size	额定流量 Rated Flow	排水口连接方式 Drainer Connection Mouth	使用温度 Operating Temperature	排水类型 Drain Type	说明 Notes
	AD202-04	G1/2	2500L/min	插8mm外径气管 8mm O.D. PU Tube	-5~55℃	自动排水 Automatic Drain	螺纹类型: -PT: PT螺纹 -NPT: NPT 螺纹 -G: G螺纹 Thread Type: -PT: PT Thread -NPT: NPT Thread -G: G Thread
AD402-04	G1/2	2500L/min	螺纹G3/8 Thread:PT3/8				

ITV系列电气比例阀 ITV Series Electro-Pneumatic Regulator

Operating Pressure: 使用压力: 0~0.8Mpa 	型号 Model	螺纹尺寸 Port Size	输入信号 Input Signal	电缆插头种类 Cable Connector Type	电源电压 Power Supply Voltage	说明 Notes
	ITV1000-01	PT1/8	0:电流型DC4~20mA(汇式) 1:电流型DC0~20mA(汇式) 2:电压型DC0~5V 3:电压型DC0~10V	S:直通型3m L:直角型3m N:无电缆插头	DC12V~DC15V, DC24V	螺纹类型: -PT: PT螺纹 -NPT: NPT 螺纹 -G: G螺纹
	ITV1000-02	PT1/4				
	ITV2000-02	PT1/4				
	ITV2000-03	PT3/8	0:Current Type 4 to 20 mA DC (Sink Type) 1:Current Type 0 to 20 mA DC (Sink Type) 2:Voltage Type 0 to 5 VDC 3:Voltage Type 0 to 10 VDC	S: Straight Type 3 m L: Right Angle Type 3 m N: Without Cable Connector		Thread Type: -PT: PT Thread -NPT: NPT Thread -G: G Thread
	ITV3000-02	PT1/4				
ITV3000-03	PT3/8					
ITV3000-04	PT1/2					

IR系列精密调压阀 IR Series Precision Regulator

<p>Operating Pressure: 使用压力:0~0.8Mpa</p> 	型号 Model	螺纹尺寸 Port Size	额定流量 Rated Flow	使用温度 Operating Temperature	灵敏度 Sensitivity	说明 Notes
	IR1000-01-BG	PT1/8	250L/min	-5~55℃	0.2%满度内 Within 0.2% Full Degree	螺纹类型: -PT: PT螺纹 -NPT: NPT 螺纹 -G: G螺纹 Thread Type: -PT: PT Thread -NPT: NPT Thread -G: G Thread
	IR1010-01-BG	PT1/8	300L/min	-5~55℃		
	IR1020-01-BG	PT1/8	450L/min	-5~55℃		
	IR2000-02-BG	PT1/4	700L/min	-5~55℃		
	IR2010-02-BG	PT1/4	950L/min	-5~55℃		
	IR2020-02-BG	PT1/4	1250L/min	-5~55℃		
	IR3000-03-BG	PT3/8	3500L/min	-5~55℃		
	IR3010-03-BG	PT3/8	4500L/min	-5~55℃		
IR3020-03-BG	PT3/8	6000L/min	-5~55℃			

AMD系列微雾分离器/AMG系列水份分离器 AMD Series Micro Mist Separator/AMG Series Water Separator

<p>Operating Pressure: 使用压力:0~0.8Mpa</p> 	型号 Model	螺纹尺寸 Port size	额定流量 Rated Flow	使用温度 Operating Temperature	排水类型 Drain Type	说明 Notes
	AMD/AMG150-01	PT1/8	200	-5~55℃	排水类型: -M: 手动排水 -A: 自动排水 Drain Type: -M: Manual Drain -A: Automatic Drain	螺纹类型: -PT: PT螺纹 -NPT: NPT 螺纹 -G: G螺纹 Thread Type: -PT: PT Thread -NPT: NPT Thread -G: G Thread
	AMD/AMG150-02	PT1/4	200	-5~55℃		
	AMD/AMG150-03	PT3/8	200	-5~55℃		
	AMD/AMG250-02	PT1/4	500	-5~55℃		
	AMD/AMG250-03	PT3/8	500	-5~55℃		
	AMD/AMG250-04	PT1/2	500	-5~55℃		
	AMD/AMG350-03	PT3/8	1000	-5~55℃		
	AMD/AMG350-04	PT1/2	1000	-5~55℃		
	AMD/AMG450-04	PT1/2	2000	-5~55℃		
	AMD/AMG450-06	PT3/4	2000	-5~55℃		
AMD/AMG550-06	PT3/4	3500	-5~55℃			
AMD/AMG550-10	PT1	3500	-5~55℃			

气源配件 Air Treatments Accessory



VP系列电磁阀 VP Series Solenoid Valve

Operating Pressure: 使用压力:0~0.8Mpa 	型号 Model	螺纹尺寸 Port Size	使用温度 Operating Temperature	线圈功率 Coil Power	线圈&位数 Coil&Position	电压 Voltage	说明 Notes
	VP342	PT1/8 PT1/4	-5~55℃	3VA	三口两位 空口:内部先导式 R:外部先导式 NO:常开 NC:常闭	DC12V DC24V DC36V AC36V AC110V AC220V AC380V	螺纹类型: -PT: PT螺纹 -NPT: NPT 螺纹 -G: G螺纹 Thread Type: -PT: PT Thread -NPT: NPT Thread -G: G Thread
	VP542	PT1/4 PT3/8	-5~55℃	3VA	3/2 Way Blank: Inner Piloted Acting Type R: Outer Piloted Acting NO: Normally Open NC: Normally Closed		
	VP742	PT3/8 PT1/2	-5~55℃	3VA			

2P/2V025/3V1系列电磁阀 2P/2V025/3V1 Series Solenoid Valve

Operating Pressure: 使用压力:0~0.8Mpa 	型号 Model	螺纹尺寸 Port Size	有效截面积 Orifice Size	使用温度 Operating Temperature	CV值 CV Value	线圈功率 Coil Power	型式 Type	电压 Voltage	说明 Notes
	2P025-06	G1/8	1.2mm ²	-5~55℃	0.23	3VA	二口二位 常闭式 2/2 Way Normally Closed	DC12V DC24V DC24V AC36V AC110V AC220V AC380V	螺纹类型: -PT: PT螺纹 -NPT: NPT 螺纹 -G: G螺纹 Thread Type: -PT: PT Thread -NPT: NPT Thread -G: G Thread
	2P025-08	G1/4	1.2mm ²	-5~55℃	0.23	3VA			
	2P160-15	G3/8	1.2mm ²	-5~55℃	0.23	3VA			
	2P200-20	G1/2	1.2mm ²	-5~55℃	0.23	3VA			
	2P250-25	G3/4	1.2mm ²	-5~55℃	0.23	3VA			
	2V025-06	G1/8	1.2mm ²	-5~55℃	0.23	3VA			
	2V025-08	G1/4	1.2mm ²	-5~55℃	0.23	3VA			
	3V1-M5	M5	2.5mm ²	-5~55℃	0.23	3VA	三口二位 常闭式 3/2 Way Normally Closed		
	3V1-06	G1/8	2.5mm ²	-5~55℃	0.23	3VA			
	3V1-08	G1/4	2.5mm ²	-5~55℃	0.23	3VA			

3V系列电磁阀 3V Series Solenoid Valve

Operating Pressure: 使用压力:0~0.8Mpa 	型号 Model	螺纹尺寸 Port Size	有效截面积 Orifice Size	使用温度 Operating Temperature	CV值 CV Value	线圈功率 Coil Power	线圈&位数 Coil&Position	电压 Voltage	说明 Notes
	3V110-06	G1/8	10mm ²	-5~55℃	0.56	3VA	三口二位 内部先导式 单线圈	DC12V DC24V DC36V AC36V AC110V AC220V AC380V	螺纹类型: -PT: PT螺纹 -NPT: NPT 螺纹 -G: G螺纹 Thread Type: -PT: PT Thread -NPT: NPT Thread -G: G Thread
	3V210-08	G1/4	14mm ²	-5~55℃	0.78	3VA	3/2Way Internally Piloted Acting Type Single Coil		
	3V310-10	G3/8	25mm ²	-5~55℃	1.40	3VA			
	3V410-15	G1/2	50mm ²	-5~55℃	2.80	3VA			
	3V120-06	G1/8	10mm ²	-5~55℃	0.56	3VA	三口二位 内部先导式 双线圈		
	3V220-08	G1/4	14mm ²	-5~55℃	0.78	3VA	3/2 Way Internally Piloted Acting Type Double Coils		
	3V320-10	G3/8	25mm ²	-5~55℃	1.40	3VA			
	3V420-15	G1/2	50mm ²	-5~55℃	2.80	3VA			

4V系列电磁阀 4V Series Solenoid Valve

Operating Pressure: 使用压力:0~0.8Mpa 	型号 Model	螺纹尺寸 Port Size	有效截面积 Orifice Size	使用温度 Operating Temperature	CV值 CV Value	线圈功率 Coil Power	线圈&位数 Coil&Position	电压 Voltage	说明 Notes
	4V110-06	G1/8	12mm ²	-5~55℃	0.56	3VA	五口二位 内部先导式 单线圈	DC12V DC24V DC36V DC36V AC110V AC220V AC380V	螺纹类型: -PT: PT螺纹 -NPT: NPT 螺纹 -G: G螺纹 Thread Type: -PT: PT Thread -NPT: NPT Thread -G: G Thread
	4V210-08	G1/4	16mm ²	-5~55℃	0.78	3VA	5/2 Way Internal Piloted Acting Type Single Coil		
	4V310-10	G3/8	30mm ²	-5~55℃	1.40	3VA			
	4V410-15	G1/2	50mm ²	-5~55℃	2.80	3VA			
	4V120-06	G1/8	10mm ²	-5~55℃	0.56	3VA	五口二位 内部先导式 双线圈		
	4V220-08	G1/4	14mm ²	-5~55℃	0.78	3VA	5/2 Way Internal Piloted Acting Type Double Coils		
	4V320-10	G3/8	25mm ²	-5~55℃	1.40	3VA			
	4V420-15	G1/2	50mm ²	-5~55℃	2.80	3VA			
	4V130-06C	G1/8	7mm ²	-5~55℃	0.67	3VA	五口三位 内部先导式 双线圈密封型		
	4V230-08C	G1/4	12mm ²	-5~55℃	0.78	3VA	5/3 Way Internal Piloted Acting Type Double Coils Closed Type		
	4V330-10C	G3/8	18mm ²	-5~55℃	1.68	3VA			
	4V430-15C	G1/2	30mm ²	-5~55℃	1.68	3VA			
	4V130-06E	G1/8	7mm ²	-5~55℃	0.67	3VA	五口三位 内部先导式 双线圈排气型		
	4V230-08E	G1/4	12mm ²	-5~55℃	0.78	3VA	5/3 Way Internal Piloted Acting Type Double Coils Exhaust Type		
	4V330-10E	G3/8	18mm ²	-5~55℃	1.68	3VA			
	4V430-15E	G1/2	30mm ²	-5~55℃	1.68	3VA			
	4V130-06P	G1/8	7mm ²	-5~55℃	0.67	3VA	五口三位 内部先导式 双线圈压力型		
	4V230-08P	G1/4	12mm ²	-5~55℃	0.78	3VA	5/3 Way Internal Piloted Acting Type Double Coils Pressure Type		
	4V330-10P	G3/8	18mm ²	-5~55℃	1.68	3VA			
4V410-15P	G1/2	30mm ²	-5~55℃	1.68	3VA?				

4M系列电磁阀 4M Series Solenoid Valve

Operating Pressure: 使用压力:0~0.8Mpa	型号 Model	螺纹尺寸 Port Size	有效截面积 Orifice Size	使用温度 Operating Temperature	CV值 CV Value	线圈功率 Coil Power	线圈&位数 Coil&Position	电压 Voltage	说明 Notes
	4M110-06	G1/8	12mm ²	-5~55℃	0.56	3VA	五口二位 内部先导式 单线圈	DC12V DC24V DC36V AC36V AC110V AC220V AC380V	螺纹类型: -PT: PT螺纹 -NPT: NPT 螺纹 -G: G螺纹 Thread Type: -PT: PT Thread -NPT: NPT Thread -G: G Thread
	4M210-08	G1/4	16mm ²	-5~55℃	0.78	3VA	5/2 Way Internally Piloted Acting Type Single Coil		
	4M310-10	G3/8	30mm ²	-5~55℃	1.40	3VA			
	4M410-15	G1/2	50mm ²	-5~55℃	2.80	3VA			
	4M120-06	G1/8	10mm ²	-5~55℃	0.56	3VA	五口二位 内部先导式 双线圈		
	4M220-08	G1/4	14mm ²	-5~55℃	0.78	3VA			
	4M320-10	G3/8	25mm ²	-5~55℃	1.40	3VA	5/2 Way Internally Piloted Acting Type Double Coils		
	4M420-15	G1/2	50mm ²	-5~55℃	2.80	3VA			
	4M130-06C	G1/8	7mm ²	-5~55℃	0.67	3VA	五口三位 内部先导式 双线圈封闭型		
	4M230-08C	G1/4	12mm ²	-5~55℃	0.78	3VA			
	4M330-10C	G3/8	18mm ²	-5~55℃	1.68	3VA	5/3 Way Internally Piloted Acting Type Double Coils Closed Type		
	4M430-15C	G1/2	30mm ²	-5~55℃	1.68	3VA			
	4M130-06E	G1/8	7mm ²	-5~55℃	0.67	3VA	五口三位 内部先导式 双线圈排气型		
	4M230-08E	G1/4	12mm ²	-5~55℃	0.78	3VA			
	4M330-10E	G3/8	18mm ²	-5~55℃	1.68	3VA	5/3 Way Internally Piloted Acting Type Double Coils Exhaust Type		
	4M430-15E	G1/2	30mm ²	-5~55℃	1.68	3VA			
4M130-06P	G1/8	7mm ²	-5~55℃	0.67	3VA	五口三位 内部先导式 双线圈压力型			
4M230-08P	G1/4	12mm ²	-5~55℃	0.78	3VA				
4M330-10P	G3/8	18mm ²	-5~55℃	1.68	3VA	5/3 Way Internally Piloted Acting Type Double Coils Pressure Type			
4M430-15P	G1/2	30mm ²	-5~55℃	1.68	3VA				

MVSC系列电磁阀 MVSC Series Solenoid Valve

Operating Pressure: 使用压力:0~0.8Mpa	型号 Model	螺纹尺寸 Port Size	有效截面积 Orifice Size	使用温度 Operating Temperature	CV值 CV Value	线圈功率 Coil Power	线圈&位数 Coil&Position	电压 Voltage	说明 Notes
	MVSC220-4E1	PT1/4	14mm ²	-5~55℃	0.78	3VA	五口二位 单线圈 5/2 Way Single Coil	DC12V DC24V DC36V AC36V AC110V AC220V AC380V	螺纹类型: -PT: PT螺纹 -NPT: NPT 螺纹 -G: G螺纹 Thread Type: -PT: PT Thread -NPT: NPT Thread -G: G Thread
	MVSC260-4E1	PT1/4	25mm ²	-5~55℃	1.40	3VA			
	MVSC300-4E1	PT1/2	50mm ²	-5~55℃	2.80	3VA			
	MVSC220-4E2	PT1/4	14mm ²	-5~55℃	0.78	3VA	五口二位 双线圈 5/2 Way Single Coil		
	MVSC260-4E2	PT1/4	25mm ²	-5~55℃	1.40	3VA			
	MVSC300-4E2	PT1/2	50mm ²	-5~55℃	2.80	3VA			
	MVSC220-4E2C	PT1/4	12mm ²	-5~55℃	0.40	3VA	五口三位 双线圈封闭型 5/3 Way Double Coils Closed Type		
	MVSC260-4E2C	PT1/4	18mm ²	-5~55℃	1.0	3VA			
	MVSC300-4E2C	PT1/2	30mm ²	-5~55℃	1.68	3VA			
	MVSC220-4E2P	PT1/4	12mm ²	-5~55℃	0.4	3VA	五口三位 双线圈压力型 5/3 Way Double Coils Pressure Type		
	MVSC260-4E2P	PT1/4	18mm ²	-5~55℃	1.0	3VA			
	MVSC300-4E2P	PT1/2	30mm ²	-5~55℃	1.68	3VA			
	MVSC220-4E2R	PT1/4	12mm ²	-5~55℃	0.4	3VA	五口三位 双线圈排气型 5/3 Way Double Coils Exhaust Type		
	MVSC260-4E2R	PT1/4	18mm ²	-5~55℃	1.0	3VA			
MVSC300-4E2R	PT1/2	30mm ²	-5~55℃	1.68	3VA				

263/802/2630系列电磁阀 263/802/2630 Series Solenoid Valve

Operating Pressure: 使用压力:0~0.8Mpa	型号 Model	螺纹尺寸 Port Size	使用温度 Operating Temperature	线圈功率 Coil Power	线圈&位数 Coil&Position	电压 Voltage	说明 Notes
	2636000	G1/4	-5~55℃	3VA	五口二位 内部先导式	DC12V DC24V DC36V AC36V AC110V AC220V AC380V	螺纹类型: -PT: PT螺纹 -NPT: NPT 螺纹 -G: G螺纹 Thread Type: -PT: PT Thread -NPT: NPT Thread -G: G Thread
	2637050	G1/4	-5~55℃	3VA			
	2636200	G1/2	-5~55℃	3VA			
	2637250	G1/2	-5~55℃	3VA	5/2 Way Internally Piloted Acting Type		
	8020750	G1/4	-5~55℃	3VA			
	8021750	G1/4	-5~55℃	3VA			
	8022750	G1/4	-5~55℃	3VA	三口二位 内部先导式		
	8020850	G1/4	-5~55℃	3VA			
	8022850	G1/4	-5~55℃	3VA			
	2630600	G1/8	-5~55℃	3VA	3/2 Way Internally Piloted Acting Type		
	2630601	G1/8	-5~55℃	3VA			
	2630700	G1/8	-5~55℃	3VA			
	2630701	G1/8	-5~55℃	3VA	四口二位 内部先导式		
				4/2 Way Internally Piloted Acting Type			

F5214系列电磁阀(老虎阀) F5214 Series Solenoid Valve(Tiger Valve)

Operating Pressure: 使用压力:0~0.8Mpa	型号 Model	螺纹尺寸 Port Size	有效截面积 Orifice Size	电压范围 Power Consumption	使用温度 Operating Temperature	型式 Type	电压 Voltage	说明 Notes
		F5214-06	G1/8	22.5mm ²	-15%~+10%	-5~60℃	五口二位 内部先导式	DC12V DC24V AC24V AC36V AC110V AC220V AC380V
	F5214-08	G1/4	22.5mm ²	-15%~+10%	-5~60℃	5/2Way Internally Piloted Acting Type		

VF系列电磁阀 VF Series Solenoid Valve

Operating Pressure: 使用压力:0~0.8Mpa	型号 Model	螺纹尺寸 Port Size	有效截面积 Orifice Size	使用温度 Operating Temperature	CV值 CV Value	线圈功率 Coil Power	线圈&位数 Coil&Position	电压 Voltage	说明 Notes
		VF3130-02	PT1/4	24mm ²	-5~55℃	6.4	3VA	五口二位单线圈 5/2 Way Single Coil	DC12V DC24V DC36V AC36V AC110V AC220V AC380V
VF5120-03		PT3/8	49mm ²	-5~55℃	11	3VA	五口二位双线圈 5/2 Way Double Coils		
VF3230-02		PT1/4	24mm ²	-5~55℃	6.4	3VA	五口三位 双线圈封闭型 5/3 Way Double Coils Closed Type		
VF5220-03		PT3/8	49mm ²	-5~55℃	11	3VA	五口三位 双线圈压力型 5/3 Way Double Coils Pressure Type		
VF3330-02		PT1/4	18mm ²	-5~55℃	4.7	3VA	五口三位 双线圈排气型 5/3 Way Double Coils Exhaust Type		
VF5320-03		PT3/8	30mm ²	-5~55℃	7.3	3VA			
VF3430-02		PT1/4	18mm ²	-5~55℃	3.7	3VA			
VF5420-03		PT3/8	26mm ²	-5~55℃	4.9	3VA			
VF3530-02		PT1/4	18mm ²	-5~55℃	4.8	3VA			
VF5520-03	PT3/8	26mm ²	-5~55℃	6.6	3VA				

SY系列电磁阀 SY Series Solenoid Valve

Operating Pressure: 使用压力:0~0.8Mpa	型号 Model	螺纹尺寸 Port Size	使用温度 Operating Temperature	CV值 CV Value	线圈&位数 Coil&Position	电压 Voltage	说明 Notes
		SY3120	M5	-10~50℃	0.16	五口二位 单线圈先导式	DC12V DC24V AC110V AC220V
SY5120		PT1/8	-10~50℃	0.49	5/2 Way Single Coil Piloted Acting Type		
SY7120		PT1/4	-10~50℃	0.93	5/2 Way Double Coil Piloted Acting Type		
SY9120		PT3/8	-10~50℃	1.9	5/2 Way Double Coil Piloted Acting Type		
SY3220		M5	-10~50℃	0.16	5/3 Way Closed Center Piloted Acting Type		
SY5220		PT1/8	-10~50℃	0.49	5/3 Way Closed Center Piloted Acting Type		
SY7220		PT1/4	-10~50℃	0.93	5/3 Way Exhaust Center Piloted Acting Type		
SY9220		PT3/8	-10~50℃	1.9	5/3 Way Exhaust Center Piloted Acting Type		
SY3320		M5	-10~50℃	0.13	5/3 Way Pressure Center Piloted Acting Type		
SY5320		PT1/8	-10~50℃	0.45	5/3 Way Pressure Center Piloted Acting Type		
SY7320		PT1/4	-10~50℃	0.7			
SY9320		PT3/8	-10~50℃	1.9			
SY3420		M5	-10~50℃	0.13			
SY5420		PT1/8	-10~50℃	0.41			
SY7420		PT1/4	-10~50℃	0.65			
SY9420		PT3/8	-10~50℃	1.9			
SY3520	M5	-10~50℃	0.15				
SY5520	PT1/8	-10~50℃	0.61				
SY7520	PT1/4	-10~50℃	0.97				
SY9520	PT3/8	-10~50℃	2.2				

SYA系列气控阀 SYA Series Air Control Valve

Operating Pressure: 使用压力:0~0.8Mpa	型号 Model	螺纹尺寸 Port Size	使用温度 Operating Temperature	CV值 CV Value	线圈&位数 Coil&Position	说明 Notes
		SYA3120	M5	-10~60℃	0.16	五口二位单气控 5/2 Way Single Air Control
SYA5120		PT1/8	-10~60℃	0.49		
SYA7120		PT1/4	-10~60℃	0.93		
SYA3220		M5	-10~60℃	0.16	五口二位双气控 5/2 Way Double Air Control	
SYA5220		PT1/8	-10~60℃	0.49		
SYA7220		PT1/4	-10~60℃	0.93		
SYA3320		M5	-10~60℃	0.13	五口二位中封式 5/2 Way Closed Center Type	
SYA5320		PT1/8	-10~60℃	0.45		
SYA7320		PT1/4	-10~60℃	0.7		
SYA3420		M5	-10~60℃	0.13	五口二位中泄式 5/2 Way Exhaust Center Type	
SYA5420		PT1/8	-10~60℃	0.41		
SYA7420		PT1/4	-10~60℃	0.65		
SYA3520		M5	-10~60℃	0.15	五口二位中压式 5/2 Way Pressure Center Type	
SYA5520		PT1/8	-10~60℃	0.61		
SYA7520		PT1/4	-10~60℃	0.97		

Q22HD系列气控阀 Q22HD Series Air Control Valve

Operating Pressure: 使用压力:0~0.8Mpa	型号 Model	螺纹尺寸 Port Size	有效截面积 Orifice Size	使用温度 Operating Temperature	CV值 CV Value	启动压力 Starting Pressure	型式 Type	说明 Notes
	Q22HD-15	G1/2	15mm	-5~85℃	4.9	0.39 Mpa	二口二位 常闭式 2/2 Way Normally Closed	螺纹类型: -PT: PT螺纹 -NPT: NPT 螺纹 -G: G螺纹 Thread Type: -PT: PT Thread -NPT: NPT Thread -G: G Thread
	Q22HD-20	G3/4	20mm	-5~85℃	9.3	0.39 MPa		
	Q22HD-25	G1	25mm	-5~85℃	22.2	0.2 MPa		
	Q22HD-35	G1-1/4	32mm	-5~85℃	32.1	0.2 MPa		
	Q22HD-40	G1-1/2	40mm	-5~85℃	49	0.2 Mpa		
Q22HD-50	G2	50mm	-5~85℃	60.7	0.2 MPa			



VT307/VX2120系列气控阀 VT307/VX2120 Series Air Control Valve

Operating Pressure: 使用压力:0~0.8Mpa	型号 Model	螺纹尺寸 Port Size	有效截面积 Orifice Size	使用温度 Operating Temperature	CV值 CV Value	线圈功率 Coil Power	型式 Type	说明 Notes
	VT307	G1/4	2.5mm ²	-5~85℃	0.23	5VA	三口二位 3/2 Way	螺纹类型: -PT: PT螺纹 -NPT: NPT 螺纹 -G: G螺纹 Thread Type: -PT: PT Thread -NPT: NPT Thread -G: G Thread
	VX2120	G1/4	2mm ²	-5~85℃	0.23	8VA	二口二位 2/2 Way	
	VX2130	G3/8	10mm ²	-5~85℃	0.23	8VA	二口二位 2/2 Way	



VTA301/VTA315系列气控阀 VTA301/VTA315 Series Air Control Valve

Operating Pressure: 使用压力:0~0.8Mpa	型号 Model	螺纹尺寸 Port Size	CV值 CV Value	使用温度 Operating Temperature	线圈&位数 Coil&Position	电压 Voltage	说明 Notes
	VTA-301-01	PT1/8	0.16	-5~55℃	二口二位 常闭式 2/2 Way Normally Closed	DC12V DC24V DC36V AC36V AC110V AC220V AC380V	螺纹类型: -PT: PT螺纹 -NPT: NPT 螺纹 -G: G螺纹 Thread Type: -PT: PT Thread -NPT: NPT Thread -G: G Thread
	VTA-301-02	PT1/4	0.16	-5~55℃			
	VTA-315-01	PT1/8	0.39	-5~55℃			
	VTA-315-02	PT1/4	0.39	-5~55℃			



3A系列气控阀 3A Series Air Control Valve

Operating Pressure: 使用压力:0~0.8Mpa	型号 Model	螺纹尺寸 Port Size	有效截面积 Orifice Size	使用温度 Operating Temperature	CV值 CV Value	消声螺纹尺寸 Silenser Port size	线圈&位数 Coil&Position	说明 Notes
	3A110-06	G1/8	10mm ²	-5~55℃	0.56	PT1/8	三口二位 单气控	螺纹类型: -PT: PT螺纹 -NPT: NPT 螺纹 -G: G螺纹
	3A210-08	G1/4	14mm ²	-5~55℃	0.78	PT1/8		
	3A310-10	G3/8	25mm ²	-5~55℃	1.40	PT1/4		
	3A410-15	G1/2	50mm ²	-5~55℃	2.80	PT1/2	3/2 Way Single Air Control	Thread Type: -PT: PT Thread -NPT: NPT Thread -G: G Thread
	3A120-06	G1/8	10mm ²	-5~55℃	0.56	PT1/8		
	3A220-08	G1/4	14mm ²	-5~55℃	0.78	PT1/8	三口二位 双气控	Thread Type: -PT: PT Thread -NPT: NPT Thread -G: G Thread
	3A320-10	G3/8	25mm ²	-5~55℃	1.40	PT1/4		
	3A420-15	G1/2	50mm ²	-5~55℃	2.80	PT1/2	3/2 Way Double Air Control	



4A系列气控阀 4A Series Air Control Valve

Operating Pressure: 使用压力:0~0.8Mpa	型号 Model	螺纹尺寸 Port Size	有效截面积 Orifice Size	使用温度 Operating Temperature	CV值 CV Value	消声螺纹尺寸 Silenser Port Size	线圈&位数 Coil&Position	说明 Notes
	4A-110-06	G1/8	12mm ²	-5~55℃	0.56	PT1/8	五口二位 单气控	螺纹类型: -PT: PT螺纹 -NPT: NPT 螺纹 -G: G螺纹 Thread Type: -PT: PT Thread -NPT: NPT Thread -G: G Thread
	4A-210-08	G1/4	16mm ²	-5~55℃	0.78	PT1/8		
	4A-310-10	G3/8	30mm ²	-5~55℃	1.40	PT1/4		
	4A-410-15	G1/2	50mm ²	-5~55℃	2.80	PT1/2	5/2 Way Single Air Control	
	4A-120-06	G1/8	10mm ²	-5~55℃	0.56	PT1/8		
	4A-220-08	G1/4	14mm ²	-5~55℃	0.78	PT1/8	五口二位 双气控	
	4A-320-10	G3/8	25mm ²	-5~55℃	1.40	PT1/4		
	4A-420-15	G1/2	50mm ²	-5~55℃	2.80	PT1/2	5/2 Way Double Air Control	
	4A-130-06C	G1/8	7mm ²	-5~55℃	0.67	PT1/8	五口三位 双气控封闭型	
	4A-230-08C	G1/4	12mm ²	-5~55℃	0.78	PT1/8		
	4A-330-10C	G3/8	18mm ²	-5~55℃	1.68	PT1/4	5/3 Way Double Air Control Closed Type	
	4A-430-15C	G1/2	30mm ²	-5~55℃	1.68	PT1/2		
	4A-130-06E	G1/8	7mm ²	-5~55℃	0.67	PT1/8	五口三位 双气控排气型	
	4A-230-08E	G1/4	12mm ²	-5~55℃	0.78	PT1/8		
	4A-330-10E	G3/8	18mm ²	-5~55℃	1.68	PT1/4	5/3 Way Double Air Control Exhaust Type	
	4A-430-15E	G1/2	30mm ²	-5~55℃	1.68	PT1/2		
	4A-130-06P	G1/8	7mm ²	-5~55℃	0.67	PT1/8	五口三位 双气控压力型	
	4A-230-08P	G1/4	12mm ²	-5~55℃	0.78	PT1/8		
	4A-330-10P	G3/8	18mm ²	-5~55℃	1.68	PT1/4	5/3 Way Double Air Control Pressure Type	
4A-430-15P	G1/2	30mm ²	-5~55℃	1.68	PT1/2			





JM系列机械阀 JM Series Mechanical Valve

Operating Pressure: 使用压力:0~0.8Mpa				型号 Model	螺纹尺寸 Port Size	有效截面积 Orifice Size	使用温度 Operating Temperature Range	CV值 CV Value	控制型式 Control Type	阀型 Valve Type	说明 Notes
				JM-05	G1/4	24mm ²	-5~55℃	1.20	旋转式 Selector	三口二位 常闭型 3/2 Way Normally Closed Type	螺纹类型: -PT: PT螺纹 -NPT: NPT 螺纹 -G: G螺纹 Thread Type: -PT: PT Thread -NPT: NPT Thread -G: G Thread
				JM-06	G1/4	24mm ²	-5~55℃	1.20	自锁式 Push Button		
				JM-06A	G1/4	24mm ²	-5~55℃	1.20	弹簧复位式 Spring Return		
				JM-07	G1/4	24mm ²	-5~55℃	1.20	滚轮式 Roller Lever		
				JM-07Y	G1/4	24mm ²	-5~55℃	1.20	摇臂式 Roller Lever		

JMJ系列机械阀 JMJ Series Mechanical Valve

基本型 Normal Type	选择型 Selection Type	选择型 Selection Type	带锁型按钮 Self Lock Push Button Type	蘑菇头按钮型 Mushroom Type	平行按钮 Flat Type	凸型按钮 Raised Button Type	滚轮杠杆型 Roller Type
							
JMJ-00	JMJ-01	JMJ-02	JMJ-03	JMJ-04	JMJ-05	JMJ-06	JMJ-07
G1/4	G1/4	G1/4	G1/4	G1/4	G1/4	G1/4	G1/4

M3系列机械阀 M3 Series Mechanical Valve

基本型 Normal Type	长柄型 Long Handle Type	短柄型 Short-Arm Type	滚轮杠杆型 Roller Type	滚轮杠杆型 Roller With Free Return Type	摇臂型 Lever Type(Y)	蘑菇头 按钮型 Mushroom Type	凸头按钮型 Raised Button Type	平头按钮型 Flat Button Type	急停撞击 按钮型 Stop Hitting Button Type	选择型 Selection Type
										
M3B	M3C	M3D	M3R	M3L	M3Y	M3PM	M3PP	M3PF	M3PL	M3HS
型号: M3-110-06 接口螺纹: G1/8				型号: M3-210-06, M3-210-08 接口螺纹: G1/8, 1/4						
Model: M3-110-06 Thread: G1/8				Model: M3-210-06, M3-210-08 Thread: G1/8, 1/4						

M5系列机械阀 M5 Series Mechanical Valve

基本型 Normal Type	长柄型 Long Handle Type	短柄型 Short-Arm Type	滚轮杠杆型 Roller Type	滚轮杠杆型 Roller With Free Return Type	摇臂型 Lever Type(Y)	蘑菇头 按钮型 Mushroom Type	凸头按钮型 Raised Button Type	平头按钮型 Flat Button Type	急停撞击 按钮型 Stop Hitting Button Type	选择型 Selection Type
										
M5B	M5C	M5D	M5R	M5L	M5Y	M5PM	M5PP	M5PF	M5PL	M5HS
型号: M5-110-06 接口螺纹: G1/8				型号: M5-210-06, M5-210-08 接口螺纹: G1/8, 1/4						
Model: M5-110-06 Thread: G1/8				Model: M5-210-06, M5-210-08 Thread: G1/8, 1/4						

MV系列机械阀 MV Series Mechanical Valve

Operating Pressure: 使用压力:0~0.8Mpa		型号 Model	螺纹尺寸 Port Size	有效截面积 Orifice Size	使用温度 Operating Temperature	CV值 CV Value	控制型式 Control Type	阀型 Valve Type	说明 Notes
		MV-08	G1/4	24mm ²	-5~55℃	1.20	旋转式 Selector	三口二位 常闭型 3/2 Way Normally Closed Type	螺纹类型: -PT: PT螺纹 -NPT: NPT 螺纹 -G: G螺纹 Thread Type: -PT: PT Thread -NPT: NPT Thread -G: G Thread
		MV-09	G1/4	24mm ²	-5~55℃	1.20	滚轮式 Roller Lever		
		MV-10	G1/4	24mm ²	-5~55℃	1.20	自锁式 Push Button		
		MV-10A	G1/4	24mm ²	-5~55℃	1.20	弹簧复位式 Spring Return		

MOV系列机械阀 MOV Series Mechanical Valve

Operating Pressure: 使用压力:0~0.8Mpa		型号 Model	螺纹尺寸 Port Size	有效截面积 Orifice Size	使用温度 Operating Temperature	CV值 CV Value	控制型式 Control Type	阀型 Valve Type	说明 Notes
		MOV-01	G1/8	24mm ²	-5~55℃	1.20	旋转式 Selector	三口二位 常闭型 3/2 Way Normally Closed Type	螺纹类型: -PT: PT螺纹 -NPT: NPT 螺纹 -G: G螺纹 Thread Type: -PT: PT Thread -NPT: NPT Thread -G: G Thread
		MOV-02	G1/8	24mm ²	-5~55℃	1.20	滚轮式 Roller Lever		
		MOV-03	G1/8	24mm ²	-5~55℃	1.20	自锁式 Push Button		
		MOV-03A	G1/8	24mm ²	-5~55℃	1.20	弹簧复位式 Spring Return		

S3-210系列机械阀 S3-210 Series Mechanical Valve

基本型 Normal Type	长柄型 Long Handle Type	短柄型 Short-Arm Type	滚轮杠杆型 Roller Type	滚轮杠杆型 Roller With Free Return Type	摇臂型 Lever Type(Y)	蘑菇头按钮型 Mushroom Type	凸头按钮型 Raised Button Type	平头按钮型 Flat Button Type	急停撞击按钮型 Stop Hitting Button Type	选择型 Selection Type
										
S3B-210	S3C-210	S3D-210	S3R-210	S3L-210	S3Y-210	S3PM-210	S3PP-210	S3PF-210	S3PL-210	S3HS-210
型号: S3-210-06 接口螺纹: G1/8					型号: S3-210-08 接口螺纹: G1/4					
Model: S3-210-06 Thread: G1/8					Model: S3-210-08 Thread: G1/4					











S3系列机械阀 S3 series Mechanical valve

基本型 Normal Type	长柄型 Long Handle Type	短柄型 Short-Arm Type	滚轮杠杆型 Roller Type	滚轮杠杆型 Roller With Free Return Type	摇臂型 Lever Type(Y)	蘑菇头按钮型 Mushroom Type	凸头按钮型 Raised Button Type	平头按钮型 Flat Button Type	急停撞击按钮型 Stop Hitting Button Type	选择型 Selection Type
										
S3B	S3C	S3D	S3R	S3L	S3Y	S3PM	S3PP	S3PF	S3PL	S3HS
型号: S3-M5 接口螺纹: M5			型号: S3-06 接口螺纹: G1/8				型号: S3-08 接口螺纹: G1/4			
Model: S3-M5 Thread: M5			Model: S3-06 Thread: G1/8				Model: S3-08 Thread: G1/4			

CM3系列机械阀 CM3 Series Mechanical Valve

基本型 Normal Type	滚轮型 Roller Lever	单向滚轮型 One Way Roller	急停按钮型 Latching Type	蘑菇头按钮型 Mushroom Push Button	凸型按钮 Raised Button Type	平头按钮型 Flat-Head Push Button	旋钮型 Selector	撞击滚轮型 Roller Plunger Type	摇臂型 Lever Type(Y)
									
CM3B	CM3R	CM3L	CM3PL	CM3PF	CM3PP	CM3PM	CM3HS	CM3V	CM3Y
G1/8	G1/8	G1/8	G1/8	G1/8	G1/8	G1/8	G1/8	G1/8	G1/8

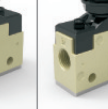
VM130、VM131系列机械阀 VM130、VM131 Series Mechanical Valve

基本型 Normal Type	滚轮型 Roller Lever	单向滚轮型 One Way Roller	急停按钮型 Latching Type	蘑菇头按钮型 Mushroom Push Button	凸型按钮 Raised Button Type	平头按钮型 Flat-Head Push Button	旋钮型 Selector	直动型 Straight Plunger Type	撞击滚轮型 Roller Plunger Type	摇臂型 Lever Type(Y)
										
VM131-01-00	VM131-01-01	VM131-01-02	VM130-01-37	VM130-01-30	VM130-01-32	VM130-01-33	VM130-01-34	VM130-01-05	VM130-01-06	VM130-01-08
G1/8	G1/8	G1/8	G1/8	G1/8	G1/8	G1/8	G1/8	G1/8	G1/8	G1/8

VM230系列机械阀 VM230 Series Mechanical Valve

基本型 Normal Type	滚轮型 Roller Lever	急停按钮型 Latching Type	蘑菇头按钮型 Mushroom Push Button	凸型按钮 Raised Button Type	平头按钮型 Flat-Head Push Button	旋钮型 Selector
						
VM230-02-00	VM230-02-01	VM230-02-37	VM230-02-30	VM230-02-32	VM230-02-33	VM230-02-34
PT1/4	PT1/4	PT1/4	PT1/4	PT1/4	PT1/4	PT1/4

3H/4H系列手板阀 3H/4H Series Hand Lever Valve

Operating Pressure: 使用压力:0~0.8Mpa	型号 Model	螺纹尺寸 Port Size	有效截面积 Orifice Size	使用温度 Operating Temperature	CV值 CV Value	控制型式 Control Type	阀型 Valve Type	说明 Notes
		3H210-08	G1/4	16mm ²	-5~55℃	0.89	手动复位式 Hand Return	三口二位 常闭式 3/2 Way Normally Closed Type
3H310-10	G3/8	25mm ²	-5~55℃	1.40				
3H410-15	G1/2	30mm ²	-5~55℃	1.68				
4H210-08	G1/4	16mm ²	-5~55℃	0.89	手动复位式 Hand Return	五口二位 5/2 Way Type		
4H310-10	G3/8	25mm ²	-5~55℃	1.40				
4H410-15	G1/2	30mm ²	-5~55℃	1.68				
4H230-08C	G1/4	16mm ²	-5~55℃	0.89	自动复位式 Automatic Return	五口三位 中位封闭型 5/3 Way Middle Closed Type		
4H330-10C	G3/8	25mm ²	-5~55℃	1.40				
4H430-15C	G1/2	30mm ²	-5~55℃	1.68				

3L/4L系列手拉阀 3L/4L Series Hand Draw Valve

Operating Pressure: 使用压力:0~0.8Mpa	型号 Model	螺纹尺寸 Port Size	有效截面积 Orifice Size	使用温度 Operating Temperature	CV值 CV Value	控制型式 Control Type	阀型 Valve Type	说明 Notes
	3L210-08	G1/4	16mm ²	-5~55℃	0.89	手动复位式 Hand Return	三口二位 常闭式 3/2 Way Normally Closed Type	螺纹类型: -PT: PT螺纹 -NPT: NPT 螺纹 -G: G螺纹 Thread Type: -PT: PT Thread -NPT: NPT Thread -G: G Thread
	3L310-10	G3/8	25mm ²	-5~55℃	1.40			
	3L410-15	G1/2	30mm ²	-5~55℃	1.68			
	4L210-08	G1/4	16mm ²	-5~55℃	0.89	手动复位式 Hand Return	五口二位 5/2 Way Type	
	4L310-10	G3/8	25mm ²	-5~55℃	1.40			
	4L410-15	G1/2	30mm ²	-5~55℃	1.68			
	4L230-08C	G1/4	16mm ²	-5~55℃	0.89	自动复位式 Automatic Return	五口三位 中位封闭型 5/3 Way Middle Closed Type	
	4L330-10C	G3/8	25mm ²	-5~55℃	1.40			
	4L430-15C	G1/2	30mm ²	-5~55℃	1.68			

JM系列手拉阀 JM Series Hand Draw Valve

Operating Pressure: 使用压力:0~0.8Mpa	型号 Model	螺纹尺寸 Port Size	有效截面积 Orifice Size	使用温度 Operating Temperature	CV值 CV Value	控制型式 Control Type	阀型 Valve Type	说明 Notes
	JM-08	G1/4	24mm ²	-5~55℃	1.20	手动复位式 Hand Return	五口二位 5/2 Way	螺纹类型: -PT: PT螺纹 -NPT: NPT 螺纹 -G: G螺纹 Thread Type: -PT: PT Thread -NPT: NPT Thread -G: G Thread
	JM-09	G3/8	24mm ²	-5~55℃	1.20			
	JM-08A	G1/4	24mm ²	-5~55℃	1.20	自动复位式 Automatic Return		
	JM-09A	G3/8	24mm ²	-5~55℃	1.20			

SH系列手拉阀 SH Series Hand Draw Valve

Operating Pressure: 使用压力:0~0.8Mpa	型号 Model	螺纹尺寸 Port Size	有效截面积 Orifice Size	使用温度 Operating Temperature	CV值 CV Value	控制型式 Control Type	阀型 Valve Type	说明 Notes
	SH-402	G1/4	24mm ²	-5~55℃	1.20	手动复位式 Hand Return	五口二位 5/2 Way	螺纹类型: -PT: PT螺纹 -NPT: NPT 螺纹 -G: G螺纹 Thread Type: -PT: PT Thread -NPT: NPT Thread -G: G Thread
	SH-403	G3/8	24mm ²	-5~55℃	1.20			
	SH-402A	G1/4	24mm ²	-5~55℃	1.20	自动复位式 Automatic Return		
	SH-403A	G3/8	24mm ²	-5~55℃	1.20			

SR系列手拉阀 SR Series Hand Draw Valve

Operating Pressure: 使用压力:0~0.8Mpa	型号 Model	螺纹尺寸 Port Size	有效截面积 Orifice Size	使用温度 Operating Temperature	CV值 CV Value	控制型式 Control Type	阀型 Valve Type	说明 Notes
	SR-08	G1/4	16mm ²	-5~55℃	0.89	手动复位式 Hand Return	三口二位常闭式 3/2 Way Normally Closed	螺纹类型: -PT: PT螺纹 -NPT: NPT 螺纹 -G: G螺纹 Thread Type: -PT: PT Thread -NPT: NPT Thread -G: G Thread
	SR110-06	G1/8	12mm ²	-5~55℃	0.67			
	SR110-08	G1/4	16mm ²	-5~55℃	0.89			
	SR210-06	G1/8	12mm ²	-5~55℃	0.67	手动复位式 Hand Return	五口二位常闭式 5/2 Way Normally Closed	
	SR210-08	G1/4	16mm ²	-5~55℃	0.89			
	SR210-06A	G1/8	12mm ²	-5~55℃	0.67			

4HV系列手转阀 4HV Series Hand Rotary Valve

Operating Pressure: 使用压力:0~0.8Mpa	型号 Model	螺纹尺寸 Port Size	有效截面积 Orifice Size	使用温度 Operating Temperature	CV值 CV Value	控制型式 Control Type	阀型 Valve Type	说明 Notes
	4HV210-06	G1/8	14mm ²	-5~55℃	0.78	手动复位式 Hand Return	四口二位 中位封闭型 4/2 Way Middle Closed Type	螺纹类型: -PT: PT螺纹 -NPT: NPT 螺纹 -G: G螺纹 Thread Type: -PT: PT Thread -NPT: NPT Thread -G: G Thread
	4HV210-08	G1/4	16mm ²	-5~55℃	0.89			
	4HV310-08	G1/4	30mm ²	-5~55℃	1.67			
	4HV310-10	G3/8	33mm ²	-5~55℃	1.83			
	4HV410-15	G1/2	88mm ²	-5~55℃	4.89			
	4HV410-20	G3/4	95mm ²	-5~55℃	5.27			
	4HV230-06	G1/8	14mm ²	-5~55℃	0.78	手动复位式 Hand Return	四口三位 中位封闭型 4/3 Way Middle Closed Type	
	4HV230-08	G1/4	16mm ²	-5~55℃	0.89			
	4HV330-08	G1/4	30mm ²	-5~55℃	1.67			
	4HV330-10	G1/8	33mm ²	-5~55℃	1.83			
	4HV430-15	G1/2	88mm ²	-5~55℃	4.89			
	4HV430-20	G3/4	95mm ²	-5~55℃	5.27			



HV系列手转阀 HV Series Hand Rotary Valve

Operating Pressure: 使用压力:0~0.8Mpa	型号 Model	螺纹尺寸 Port Size	有效截面积 Orifice Size	使用温度 Operating Temperature	CV值 CV Value	控制型式 Control Type	阀型 Valve Type	说明 Notes	
		HV-02	G1/4	16mm ²	-5~55℃	0.89	手动复位式 Hand Return	四口三位 4/3 Way	螺纹类型: -PT: PT螺纹 -NPT: NPT 螺纹 -G: G螺纹 Thread Type: -PT: PT Thread -NPT: NPT Thread -G: G Thread
		HV-03	G3/8	16mm ²	-5~55℃	0.89		四口三位 4/3 Way	
		HV-04	G1/2	16mm ²	-5~55℃	0.89	中位封闭型 Middle Closed Type	四口三位 4/3 Way	
		HV200-02	G1/4	16mm ²	-5~55℃	0.89		五口三位 5/3 Way	

VH系列手转阀 VH Series Hand Rotary Valve

Operating Pressure: 使用压力:0~0.8Mpa	型号 Model	螺纹尺寸 Port Size	有效截面积 Orifice Size	使用温度 Operating Temperature	CV值 CV Value	控制型式 Control Type	阀型 Valve Type	说明 Notes	
		VH200-02	G1/4	16mm ²	-5~55℃	0.89	手动复位式 Hand Return	五口三位 5/3 Way	螺纹类型: -PT: PT螺纹 -NPT: NPT 螺纹 -G: G螺纹 Thread Type: -PT: PT Thread -NPT: NPT Thread -G: G Thread
		VH200-08	G1/4	16mm ²	-5~55℃	0.89		四口三位 中位封闭型	
		VH200-08D	G1/4	16mm ²	-5~55℃	0.89		4/3 Way Middle Closed Type	
		VH200-08L	G1/4	16mm ²	-5~55℃	0.89			

3F系列脚踏阀 3F Series Foot Valve

Operating Pressure: 使用压力:0~0.8Mpa	型号 Model	螺纹尺寸 Port Size	有效截面积 Orifice Size	使用温度 Operating Temperature	阀型 Valve Type	控制型式 Control Type	说明 Notes	
		3F210-06	G1/8		-20~70℃	三口二位(标准型) 3/2 Way (Standard Type)	脚踏控制直动式 常闭型 Foot Control Direct Motion Normally Closed Type	螺纹类型: -PT: PT螺纹 -NPT: NPT 螺纹 -G: G螺纹 Thread Type: -PT: PT Thread -NPT: NPT Thread -G: G Thread
		3F210-08	G1/4		-20~70℃			
		3FM210-M5	M5		-20~70℃	三口二位(迷你型) 3/2 Way (Mini Type)		
		3FM210-06	G1/8		-20~70℃			
		3FM210-08	G1/4		-20~70℃			

4F系列脚踏阀 4F Series Foot Valve

Operating Pressure: 使用压力:0~0.8Mpa	型号 Model	螺纹尺寸 Port Size	有效截面积 Orifice Size	使用温度 Operating Temperature	CV值 CV Value	控制型式 Control Type	阀型 Valve Type	说明 Notes	
		4F210-08	G1/4	16mm ²	-5~55℃	0.89	空白:标准型 Blank: Without Lock Type	五口二位 5/2 Way	螺纹类型: -PT: PT螺纹 -NPT: NPT 螺纹 -G: G螺纹 Thread Type: -PT: PT Thread -NPT: NPT Thread -G: G Thread
		4F210-08L	G1/4	16mm ²	-5~55℃	0.89	L:带锁型 L: With Lock Type		
		4F210-08F	G1/4	24mm ²	-5~55℃	1.20	F:带保护罩型 F: With Guard Type		
		4F210-08LF	G1/4	24mm ²	-5~55℃	1.20	LF:带锁带保护罩型 LF: With Lock and Guard Type		

FV系列脚踏阀 FV Series Foot Valve

Operating Pressure: 使用压力:0~0.8Mpa	型号 Model	螺纹尺寸 Port Size	有效截面积 Orifice Size	使用温度 Operating Temperature	CV值 CV Value	控制型式 Control Type	阀型 Valve Type	说明 Notes	
		FV-02	G1/4	16mm ²	-5~55℃	0.89	弹簧复位式 Spring Return	三口二位常闭型 3/2 Way Normally Closed Type	螺纹类型: -PT: PT螺纹 -NPT: NPT 螺纹 -G: G螺纹 Thread Type: -PT: PT Thread -NPT: NPT Thread -G: G Thread
		FV320	G1/4	16mm ²	-5~55℃	0.89	弹簧复位式 Spring Return		
		FV420	G1/4	16mm ²	-5~55℃	0.89	弹簧复位式 Spring Return	四口二位常闭型 4/2 Way Normally Closed Type	

ST系列脚踏阀 ST Series Foot Valve

Operating Pressure: 使用压力:0~0.8Mpa	型号 Model	螺纹尺寸 Port Size	有效截面积 Orifice Size	使用温度 Operating Temperature	CV值 CV Value	控制型式 Control Type	阀型 Valve Type	说明 Notes	
		ST-402	G1/4	24mm ²	-5~55℃	1.20	手动复位式 Hand Return	五口二位 5/2 Way	螺纹类型: -PT: PT螺纹 -NPT: NPT 螺纹 -G: G螺纹 Thread Type: -PT: PT Thread -NPT: NPT Thread -G: G Thread
		ST-403	G3/8	24mm ²	-5~55℃	1.20			
		ST-402A	G1/4	24mm ²	-5~55℃	1.20	弹簧复位式 Spring Return		
		ST-403A	G3/8	24mm ²	-5~55℃	1.20			

K系列脚踏阀 K Series Foot Valve

Operating Pressure: 使用压力:0~0.8Mpa 	型号 Model	螺纹尺寸 Port Size	有效截面积 Orifice Size	使用温度 Operating Temperature	阀型 Valve Type	说明 Notes
	K23R7-8	G1/4	6mm ²	-5~55℃	三口二位 3/2 Way	螺纹类型: -PT: PT螺纹 -NPT: NPT 螺纹 -G: G螺纹 Thread Type: -PT: PT Thread -NPT: NPT Thread -G: G Thread
	K25R7-8	G1/4	6mm ²	-5~55℃		
	K25R7-10	G3/8	8mm ²	-5~55℃	五口二位 5/2 Way	
K25R7-15	G1/2	8mm ²	-5~55℃			

CV系列单向阀 CV Series Check Valve

Operating Pressure: 使用压力:0~0.8Mpa 	型号 Model	螺纹尺寸 Port Size	流量孔径 Effective Area	使用温度 Operating Temperature	使用介质 Using Medium	材质 Material	说明 Notes
	CV-01	G1/8	6mm	-5~55℃	空气 Air	铜 Brass	螺纹类型: -PT: PT螺纹 -NPT: NPT 螺纹 -G: G螺纹 Thread Type: -PT: PT Thread -NPT: NPT Thread -G: G Thread
	CV-02	G1/4	8mm	-5~55℃			
	CV-03	G3/8	10mm	-5~55℃			
CV-04	G1/2	15mm	-5~55℃				

LCV系列单向阀 LCV Series Check Valve

Operating Pressure: 使用压力:0~0.8Mpa 	型号 Model	螺纹尺寸 Port Size	流量孔径 Effective Area	使用温度 Operating Temperature	使用介质 Using Medium	材质 Material	说明 Notes
	LCV-06	G1/8	6mm	-5~55℃	空气 Air	铝合金 Aluminum Alloy	螺纹类型: -PT: PT螺纹 -NPT: NPT 螺纹 -G: G螺纹 Thread Type: -PT: PT Thread -NPT: NPT Thread -G: G Thread
	LCV-08	G1/4	8mm	-5~55℃			
	LCV-10	G3/8	10mm	-5~55℃			
	LCV-15	G1/2	15mm	-5~55℃			
	LCV-20	G3/4	20mm	-5~55℃			
LCV-25	G1	25mm	-5~55℃				

ST系列梭阀 ST Series Shuttle Valve

Operating Pressure: 使用压力:0.05~0.8Mpa 	型号 Model	螺纹尺寸 Port Size	使用温度 Operating Temperature	使用介质 Using Medium	最低启动压力 MIN. Operating Pressure	材质 Material	说明 Notes
	ST-01	G1/8	-5~55℃	空气 Air	0.05Mpa	铝合金 Aluminum Alloy	螺纹类型: -PT: PT螺纹 -NPT: NPT 螺纹 -G: G螺纹 Thread Type: -PT: PT Thread -NPT: NPT Thread -G: G Thread
	ST-02	G1/4	-5~55℃				
	ST-03	G3/8	-5~55℃				
ST-04	G1/2	-5~55℃					

KV系列梭阀 KV Series Shuttle Valve

Operating Pressure: 使用压力:0.05~0.8Mpa 	型号 Model	螺纹尺寸 Port Size	使用温度 Operating Temperature	使用介质 Using Medium	最低启动压力 MIN. Operating Pressure	材质 Material	说明 Notes
	KV-06	G1/8	-5~55℃	空气 Air	0.05Mpa	铝合金 Aluminum Alloy	螺纹类型: -PT: PT螺纹 -NPT: NPT 螺纹 -G: G螺纹 Thread Type: -PT: PT Thread -NPT: NPT Thread -G: G Thread
	KV-08	G1/4	-5~55℃				
	KV-10	G3/8	-5~55℃				
	KV-15	G1/2	-5~55℃				
	KV-20	G3/4	-5~55℃				
KV-25	G1	-5~55℃					

KKP系列快速排气阀 KKP Quick Exhaust Valve

Operating Pressure: 使用压力:0.05~0.8Mpa 	型号 Model	螺纹尺寸 Port Size	使用温度 Operating Temperature	使用介质 Using Medium	最低启动压力 MIN. Operating Pressure	材质 Material	说明 Notes
	KKP-06	G1/8	-5~55℃	空气 Air	0.05Mpa	铝合金 Aluminum Alloy	螺纹类型: -PT: PT螺纹 -NPT: NPT 螺纹 -G: G螺纹 Thread Type: -PT: PT Thread -NPT: NPT Thread -G: G Thread
	KKP-08	G1/4	-5~55℃				
	KKP-10	G3/8	-5~55℃				
	KKP-15	G1/2	-5~55℃				
	KKP-20	G3/4	-5~55℃				
KKP-25	G1	-5~55℃					

QE系列快速排气阀 QE Series Quick Exhaust Valve

Operating Pressure: 使用压力:0~0.8Mpa 	型号 Model	螺纹尺寸 Port Size	流量孔径 Effective Area	使用温度 Operating Temperature	使用流体 Fluid	材质 Material	说明 Notes
	QE-01	G1/8	3.8mm	-5~55℃	空气 Air	铝合金 Aluminum Alloy	螺纹类型: -PT: PT螺纹 -NPT: NPT 螺纹 -G: G螺纹 Thread Type: -PT: PT Thread -NPT: NPT Thread -G: G Thread
	QE-02	G1/4	6mm	-5~55℃			
	QE-03	G3/8	32mm	-5~55℃			
QE-04	G1/2	32.8mm	-5~55℃				

BQE系列快速排气阀 BQE Series Quick Exhaust Valve

Operating Pressure: 使用压力:0~0.8Mpa 	型号 Model	螺纹尺寸 Port Size	有效截面积 Orifice Size	使用温度 Operating Temperature	使用流体 Fluid	本体材质 Body Material	说明 Notes
	BQE-01	G1/8	3.8mm	-5~55℃	空气 Air	铜 Brass	螺纹类型: -PT: PT螺纹 -NPT: NPT 螺纹 -G: G螺纹 Thread Type: -PT: PT Thread -NPT: NPT Thread -G: G Thread
	BQE-02	G1/4	6mm	-5~55℃			
	BQE-03	G3/8	32mm	-5~55℃			
	BQE-04	G1/2	32.8mm	-5~55℃			

SEU系列快速排气阀 SEU Series Quick Exhaust Valve

Operating Pressure: 使用压力:0~0.8Mpa 	型号 Model	螺纹尺寸 Port Size	有效截面积 Orifice Size	使用温度 Operating Temperature	使用流体 Fluid	本体材质 Body Material	说明 Notes
	SEU-01	G1/8	3.8mm	-5~55℃	空气 Air	铝合金 Aluminum Alloy	螺纹类型: -PT: PT螺纹 -NPT: NPT 螺纹 -G: G螺纹 Thread Type: -PT: PT Thread -NPT: NPT Thread -G: G Thread
	SEU-02	G1/4	6mm	-5~55℃			
	SEU-03	G3/8	32mm	-5~55℃			
	SEU-04	G1/2	32.8mm	-5~55℃			

KLA系列单向节流阀 KLA Series One Way Throttle Valve

Operating Pressure: 使用压力:0~0.8Mpa 	型号 Model	螺纹尺寸 Port Size	使用温度 Operating Temperature	使用介质 Using Medium	材质 Material	说明 Notes
	KLA-6	G1/8	-5~55℃	空气 Air	铝合金 Aluminum Alloy	螺纹类型: -PT: PT螺纹 -NPT: NPT 螺纹 -G: G螺纹 Thread Type: -PT: PT Thread -NPT: NPT Thread -G: G Thread
	KLA-8	G1/4	-5~55℃			
	KLA-10	G3/8	-5~55℃			
	KLA-15	G1/2	-5~55℃			
	KLA-20	G3/4	-5~55℃			
	KLA-25	G1	-5~55℃			
	KLA-40	G1-1/2	-5~55℃			
KLA-50	G2	-5~55℃				

ASC系列流量控制阀 ASC Series Speed Control Valve

Operating Pressure: 使用压力:0~0.8Mpa 	型号 Model	螺纹尺寸 Port Size	有效截面积 Orifice Size	使用温度 Operating Temperature	使用流体 Fluid	材质 Material	说明 Notes
	ASC-06	G1/8	3.8mm	-5~55℃	空气 Air	铝合金 Aluminum Alloy	螺纹类型: -PT: PT螺纹 -NPT: NPT 螺纹 -G: G螺纹 Thread Type: -PT: PT Thread -NPT: NPT Thread -G: G Thread
	ASC-08	G1/4	6mm	-5~55℃			
	ASC-10	G3/8	32mm	-5~55℃			
	ASC-15	G1/2	32.8mm	-5~55℃			

ASC系列流量控制阀 ASC Series Speed Control Valve

Operating Pressure: 使用压力:0~0.8Mpa 	型号 Model	螺纹尺寸 Port Size	有效截面积 Orifice Size	使用温度 Operating Temperature	使用流体 Fluid	材质 Material	说明 Notes
	ASC100-M5	M5	2.0mm	-5~55℃	空气 Air	铝合金 Aluminum Alloy	螺纹类型: -PT: PT螺纹 -NPT: NPT 螺纹 -G: G螺纹 Thread Type: -PT: PT Thread -NPT: NPT Thread -G: G Thread
	ASC100-06	G1/8	3.8mm	-5~55℃			
	ASC200-08	G1/4	6mm	-5~55℃			
	ASC300-10	G3/8	32mm	-5~55℃			
	ASC300-15	G1/2	32.8mm	-5~55℃			

RE系列流量控制阀 RE Series Speed Control Valve

Operating Pressure: 使用压力:0~0.8Mpa 	型号 Model	螺纹尺寸 Port Size	有效截面积 Orifice Size	使用温度 Operating Temperature	使用流体 Fluid	材质 Material	说明 Notes
	RE-01	G1/8	3.8mm	-5~55℃	空气 Air	铝合金 Aluminum Alloy	螺纹类型: -PT: PT螺纹 -NPT: NPT 螺纹 -G: G螺纹 Thread Type: -PT: PT Thread -NPT: NPT Thread -G: G Thread
	RE-02	G1/4	6mm	-5~55℃			
	RE-03	G3/8	32mm	-5~55℃			
	RE-04	G1/2	32.8mm	-5~55℃			

SMF系列电磁脉冲阀 SMF Series Solenoid Pulse Valve

Operating Pressure: 使用压力:0~0.8Mpa 	型号 Model	螺纹尺寸 Port Size	流量孔径 Effective Area	使用温度 Operating Temperature	CV值 CV Value	线圈功率 Coil Power	型式 Type	电压 Voltage	说明 Notes
	SMF-Z-15P	G1/2	15mm	-5~60℃	4.80	12VA	二口二位 常闭式 2/2 Way Normally Closed	DC12V DC24V AC24V AC36V AC110V AC220V AC380V	螺纹类型: -PT: PT螺纹 -NPT: NPT 螺纹 -G: G螺纹 Thread Type: -PT: PT Thread -NPT: NPT Thread -G: G Thread
	SMF-Z-20P	G3/4	20mm	-5~60℃	7.60	12VA			
	SMF-Z-25P	G1	25mm	-5~60℃	12	12VA			
	SMF-Z-35P	G1-1/2	35mm	-5~60℃	18	12VA			
	SMF-Z-40S	G1-1/2	40mm	-5~60℃	20	12VA			
	SMF-Z-50S	G2	50mm	-5~60℃	48	12VA			
	SMF-Z-62S	G2-1/2	62mm	-5~60℃	60	12VA			
SMF-Z-76S	G3	76mm	-5~60℃	75	12VA				

SMF-Y系列淹没式电磁脉冲阀 SMF-Y Series Submerged Pulse Valve

Operating Pressure: 使用压力:0~0.8Mpa 	型号 Model	螺纹尺寸 Port Size	流量孔径 Effective Area	使用温度 Operating Temperature	CV值 CV Value	线圈功率 Coil Power	型式 Type	电压 Voltage	说明 Notes
	SMF-Y-15P	G1/2	15mm	-5~60℃	4.80	12VA	二口二位 常闭式 2/2 Way Normally Closed	DC12V DC24V AC24V AC36V AC110V AC220V AC380V	螺纹类型: -PT: PT螺纹 -NPT: NPT 螺纹 -G: G螺纹 Thread Type: -PT: PT Thread -NPT: NPT Thread -G: G Thread
	SMF-Y-20P	G3/4	20mm	-5~60℃	7.60	12VA			
	SMF-Y-25P	G1	25mm	-5~60℃	12	12VA			
	SMF-Y-40P	G1-1/2	40mm	-5~60℃	20	12VA			
	SMF-Y-50S	G2	50mm	-5~60℃	48	12VA			
	SMF-Y-62S	G2-1/2	62mm	-5~60℃	60	12VA			
	SMF-Y-76S	G3	76mm	-5~60℃	75	12VA			

SMF-Z系列管式电磁脉冲阀 SMF-Z Series Pipe Connected Type Pulse Valve

Operating Pressure: 使用压力:0~0.8Mpa 	型号 Model	公称通径 Nominal Diameter	连接管径 Connecting Pipe Diameter	材质 Material	型式 Type	电压 Voltage	说明 Notes
	SMF-Z-25DD	25mm	34	不锈钢 Stainless Steel	二口二位 常闭式 2/2 Way Normally Closed	DC12V DC24V AC24V AC36V AC110V AC220V AC380V	螺纹类型: -PT: PT螺纹 -NPT: NPT 螺纹 -G: G螺纹 Thread Type: -PT: PT Thread -NPT: NPT Thread -G: G Thread
	SMF-Z-45DD	45mm	49				

ASV200系列不锈钢角座阀 ASV200 Series Stainless Steel Angle Seat Valve

Operating Pressure: 使用压力:0~0.8Mpa 	型号 Model	螺纹尺寸 Port Size	有效截面积 Orifice Size	使用温度 Operating Temperature	CV值 CV Value	启动压力 Starting Pressure	活塞直径 Piston DIA.	型式 Type	说明 Notes
	ASV200-04	G1/2	15mm	-5~185℃	4.9	0.39 Mpa	50mm	二口二位 常闭式 2/2 Way Normally Closed	螺纹类型: -PT: PT螺纹 -NPT: NPT 螺纹 -G: G螺纹 Thread Type: -PT: PT Thread -NPT: NPT Thread -G: G Thread
	ASV200-06	G3/4	20mm	-5~185℃	9.3	0.39 MPa	50mm		
	ASV200-10	G1	25mm	-5~185℃	22.2	0.2 MPa	63mm		
	ASV200-12	G1-1/4	32mm	-5~185℃	32.1	0.2 MPa	63mm		
	ASV200-14	G1-1/2	40mm	-5~185℃	49	0.2 Mpa	63mm		
	ASV200-20	G2	50mm	-5~185℃	60.7	0.2 MPa	63mm		

ASV200-S系列不锈钢角座阀 ASV200-S Series Stainless Steel Angle Seat Valve

Operating Pressure: 使用压力:0~0.8Mpa 	型号 Model	螺纹尺寸 Port Size	有效截面积 Orifice Size	使用温度 Operating Temperature	CV值 CV Value	启动压力 Starting Pressure	活塞直径 Piston DIA.	型式 Type	说明 Notes
	ASV200-04-S	G1/2	15mm	-5~185℃	4.9	0.39 Mpa	50mm	二口二位 常闭式 2/2 Way Normally Closed	螺纹类型: -PT: PT螺纹 -NPT: NPT 螺纹 -G: G螺纹 Thread Type: -PT: PT Thread -NPT: NPT Thread -G: G Thread
	ASV200-06-S	G3/4	20mm	-5~185℃	9.3	0.39 MPa	50mm		
	ASV200-10-S	G1	25mm	-5~185℃	22.2	0.2 MPa	63mm		
	ASV200-12-S	G1-1/4	32mm	-5~185℃	32.1	0.2 MPa	63mm		
	ASV200-14-S	G1-1/2	40mm	-5~185℃	49	0.2 Mpa	63mm		
	ASV200-20-S	G2	50mm	-5~185℃	60.7	0.2 MPa	63mm		

JZF系列不锈钢角座阀 JZF Series Stainless Steel Angle Seat Valve

Operating Pressure: 使用压力:0~0.8Mpa 	型号 Model	螺纹尺寸 Port Size	DN尺寸 Dn Size	使用温度 Operating Temperature	CV值 CV Value	活塞直径 Piston DIA.	型式 Type	说明 Notes
	JZF15	G1/2	DN15	-5~185℃	5	50mm	二口二位 空白:常闭 NO:常开	螺纹类型: -PT: PT螺纹 -NPT: NPT 螺纹 -G: G螺纹
	JZF20	G3/4	DN20	-5~185℃	9	50mm		
	JZF25	G1	DN25	-5~185℃	20	50mm	2/2 Way Blank: Normally Closed No: Normally Open	Thread Type: -PT: PT Thread -NPT: NPT Thread -G: G Thread
	JZF32	G1-1/4	DN32	-5~185℃	28	63mm		
	JZF40	G1-1/2	DN40	-5~185℃	43	63mm		

JZF-S系列不锈钢角座阀 JZF-S Series Stainless Steel Angle Seat Valve

Operating Pressure: 使用压力:0~1.6Mpa 	型号 Model	螺纹尺寸 Port Size	DN尺寸 DN Size	使用温度 Operating Temperature	CV值 CV Value	活塞直径 Piston DIA.	型式 Type	说明 Notes
	JZF-S-15	G1/2	DN15	-5~185℃	5	50mm	二口二位 空开:常闭 NO:常开	螺纹类型: -PT: PT螺纹 -NPT: NPT 螺纹 -G: G螺纹
	JZF-S-20	G3/4	DN20	-5~185℃	9	50mm		
	JZF-S-25	G1	DN25	-5~185℃	20	50mm	2/2 Way Blank: Normally Closed No: Normally Open	Thread Type: -PT: PT Thread -NPT: NPT Thread -G: G Thread
	JZF-S-32	G1-1/4	DN32	-5~185℃	28	63mm		
	JZF-S-40	G1-1/2	DN40	-5~185℃	43	63mm		

AT系列气动执行器 AT Series Pneumatic Actuator

	型号 Model	螺纹尺寸 Port Size	DN尺寸 DN Size	使用温度 Operating Temperature	旋转角度 Rotation Angle	型式 Type	说明 Notes
	AT52	G1/4	DN8	-20~80℃	90° 120° 180°	SC: 单作用正转 SD: 单作用反转 DR: 双作用正转 DL: 双作用反转	螺纹类型: -PT: PT螺纹 -NPT: NPT 螺纹 -G: G螺纹
	AT63	G1/4	DN8	-20~80℃	90° 120° 180°		
	AT75	G1/4	DN8	-20~80℃	90° 120° 180°		
	AT83	G1/4	DN8	-20~80℃	90° 120° 180°	SC: Single Acting Forward Rotation SD: Single Acting Reveral Rotation DR: Double Acting Forward Rotation DL: Double Acting Reveral Rotation	Thread Type: -PT: PT Thread -NPT: NPT Thread -G: G Thread
	AT92	G1/4	DN8	-20~80℃	90° 120° 180°		
	AT105	G1/4	DN8	-20~80℃	90° 120° 180°		
	AT125	G1/4	DN8	-20~80℃	90° 120° 180°		
	AT140	G1/4	DN8	-20~80℃	90° 120° 180°		

Q641F系列气动法兰球阀 Q641F Series Pneumatic Flanged Ball Valve

	型号 Model	螺纹尺寸 Port Size	DN尺寸 DN Size	使用温度 Operating Temperature	材质 Material	型式 Type	说明 Notes
	Q641F-15	G1/2	DN15	-20~80℃	阀轴材质: 不锈钢 阀体材质: 球墨铸铁、碳钢、不锈钢 球体材质: 不锈钢	密封类型: PTFE、 PPL、 金属密封	螺纹类型: -PT: PT螺纹 -NPT: NPT 螺纹 -G: G螺纹
	Q641F-20	G3/4	DN20	-20~80℃			
	Q641F-32	G1-1/4	DN32	-20~80℃			
	Q641F-40	G1-1/2	DN40	-20~80℃	Valve Shaft: Stainless Steel Valve Body: Nodular Cast Iron, Carbon Steel, Stainless Steel Valve Spherome: Stainless Steel	Seal Type: PTFE Seal, PPL Seal, Metal Seal	Thread Type: -PT: PT Thread -NPT: NPT Thread -G: G Thread
	Q641F-50	G2	DN50	-20~80℃			
	Q641F-65	G2-1/2	DN65	-20~80℃			
	Q641F-80	G3	DN80	-20~80℃			
	Q641F-100	G4	DN100	-20~80℃			

D671X系列气动对夹蝶阀 D671X Series Pneumatic Wafer Butterfly Valve

	型号 Model	螺纹尺寸 Port Size	DN尺寸 DN Size	使用温度 Operating Temperature	材质 Material	型式 Type	说明 Notes
	D671X-40	G1-1/2	DN40	-20~80℃	阀轴材质: 碳钢、不锈钢 阀体材质: 球墨铸铁、不锈钢 阀板材质: 球墨铸铁、不锈钢、尼龙	双作用活塞式 弹簧复位式	螺纹类型: -PT: PT螺纹 -NPT: NPT 螺纹 -G: G螺纹
	D671X-50	G2	DN50	-20~80℃			
	D671X-65	G2-1/2	DN65	-20~80℃			
	D671X-80	G3	DN80	-20~80℃	Valve Shaft: Carbon Steel, Stainless Steel Valve Body: Nodular Cast Iron, Stainless Steel Valve Plate: Nodular Cast Iron, Stainless Steel, Nylon.	Double Acting Piston Type Spring Return Type	Thread Type: -PT: PT Thread -NPT: NPT Thread -G: G Thread
	D671X-100	G4	DN100	-20~80℃			
	D671X-125	G5	DN125	-20~80℃			
	D671X-150	G6	DN150	-20~80℃			
	D671X-200	G8	DN200	-20~80℃			

D943系列电动硬密封对夹蝶阀 D943 Series Electric Wafer Butterfly Valve

	型号 Model	螺纹尺寸 Port Size	DN尺寸 DN Size	使用温度 Operating Temperature	材质 Material	型式 Type	说明 Notes
	D943-50	G2	DN50	-20~80℃	阀轴材质: 不锈钢 阀体材质: 不锈钢 阀板材质: 不锈钢	驱动方式: 电动	螺纹类型: -PT: PT螺纹 -NPT: NPT 螺纹 -G: G螺纹
	D943-65	G2-1/2	DN65	-20~80℃			
	D943-80	G3	DN80	-20~80℃			
	D943-100	G4	DN100	-20~80℃	Valve Shaft: Stainless Steel Valve Body: Stainless Steel Valve Plate: Stainless Steel	Driving Method: Electric Drive	Thread Type: -PT: PT Thread -NPT: NPT Thread -G: G Thread
	D943-125	G5	DN125	-20~80℃			
	D943-150	G6	DN150	-20~80℃			
	D943-200	G8	DN200	-20~80℃			
	D943-250	G10	DN250	-20~80℃			

2S系列不锈钢电磁阀 2S Series Solenoid Valve With Stainless Steel Body

Operating Pressure: 使用压力:0~0.8Mpa 	型号 Model	螺纹尺寸 Port Size	流量孔径 Effective Area	使用温度 Operating Temperature	CV值 CV Value	型式 Type	电压 Voltage	说明 Notes
	2S025-08	G1/4	2.5mm	-5~85℃	0.23	二口二位 直动式 常闭型 2/2 Way Direct Acting & Normally Closed Type	DC12V DC24V AC24V AC36V AC110V AC220V AC380V	螺纹类型: -PT: PT螺纹 -NPT: NPT 螺纹 -G: G螺纹 Thread Type: -PT: PT Thread -NPT: NPT Thread -G: G Thread
	2S040-10	G3/8	4mm	-5~85℃	0.23			
	2S160-15	G1/2	15mm	-5~85℃	4.80			
	2S200-20	G3/4	20mm	-5~85℃	7.60			
	2S250-25	G1	25mm	-5~85℃	12			
	2S350-35	G1-1/4	35mm	-5~85℃	24			
	2S400-40	G1-1/2	40mm	-5~85℃	29			
	2S500-50	G2	50mm	-5~85℃	48			

2WB系列不锈钢电磁阀 2WB Series Solenoid Valve With Stainless Steel Body

Operating Pressure: 使用压力:0~0.8Mpa 	型号 Model	螺纹尺寸 Port Size	流量孔径 Effective Area	使用温度 Operating Temperature	CV值 CV Value	线圈功率 Coil Power	型式 Type	电压 Voltage	说明 Notes
	2WB025-06	G1/8	2.5mm	-5~85℃	0.23	15VA	二口二位 先导式 常闭型 2/2 Way Piloted Acting & Normally Closed Type	DC12V DC24V AC24V AC36V AC110V AC220V AC380V	螺纹类型: -PT: PT螺纹 -NPT: NPT 螺纹 -G: G螺纹 Thread Type: -PT: PT Thread -NPT: NPT Thread -G: G Thread
	2WB025-08	G1/4	2.5mm	-5~85℃	0.23	15VA			
	2WB040-10	G3/8	4mm	-5~85℃	0.60	20VA			
	2WB160-15	G1/2	16mm	-5~85℃	4.80	20VA			
	2WB200-20	G3/4	20mm	-5~85℃	7.60	20VA			
	2WB250-25	G1	25mm	-5~85℃	12	20VA			
	2WB350-35	G1-1/4	35mm	-5~85℃	24	50VA			
	2WB400-40	G1-1/2	40mm	-5~85℃	29	50VA			
2WB500-50	G2	50mm	-5~85℃	48	50VA				

PU220S系列不锈钢电磁阀 PU220S Series Solenoid Valve With Stainless Steel Body

Operating Pressure: 使用压力:0~0.8Mpa 	型号 Model	螺纹尺寸 Port Size	流量孔径 Effective Area	使用温度 Operating Temperature	CV值 CV Value	线圈功率 Coil Power	型式 Type	电压 Voltage	说明 Notes
	PU220-01S	G1/8	1.5mm	-5~85℃	0.10	22VA	二口二位 直动式 常闭型 2/2 Way Direct Acting & Normally Closed Type	DC12V DC24V AC24V AC36V AC110V AC220V AC380V	螺纹类型: -PT: PT螺纹 -NPT: NPT 螺纹 -G: G螺纹 Thread Type: -PT: PT Thread -NPT: NPT Thread -G: G Thread
	PU220-02S	G1/4	2.3mm	-5~85℃	0.18	22VA			
	PU220-03S	G3/8	8mm	-5~85℃	1.00	22VA			
	PU220-04S	G1/2	13mm	-5~85℃	4.00	22VA			
	PU220-06S	G3/4	20mm	-5~85℃	8.60	22VA			
	PU220-08S	G1	25mm	-5~85℃	11.0	22VA			

2WBK系列不锈钢电磁阀 2WBK Series Solenoid Valve With Stainless Steel Body

Operating Pressure: 使用压力:0~0.8Mpa 	型号 Model	螺纹尺寸 Port Size	流量孔径 Effective Area	使用温度 Operating Temperature	CV值 CV Value	线圈功率 Coil Power	型式 Type	电压 Voltage	说明 Notes
	2WBK025-06	G1/8	2.5mm	-5~85℃	0.23	15VA	二口二位 先导式 常开型 2/2 Way Piloted Acting & Normally Open Type	DC12V DC24V AC24V AC36V AC110V AC220V AC380V	螺纹类型: -PT: PT螺纹 -NPT: NPT 螺纹 -G: G螺纹 Thread Type: -PT: PT Thread -NPT: NPT Thread -G: G Thread
	2WBK025-08	G1/4	2.5mm	-5~85℃	0.23	15VA			
	2WBK040-10	G3/8	4mm	-5~85℃	0.60	20VA			
	2WBK160-15	G1/2	16mm	-5~85℃	4.80	20VA			
	2WBK200-20	G3/4	20mm	-5~85℃	7.60	20VA			
	2WBK250-25	G1	25mm	-5~85℃	12	20VA			
	2WBK350-35	G1-1/4	35mm	-5~85℃	24	50VA			
	2WBK400-40	G1-1/2	40mm	-5~85℃	29	50VA			
2WBK500-50	G2	50mm	-5~85℃	48	50VA				

2WBF系列不锈钢电磁阀 2WBF Series Solenoid Valve With Stainless Steel Body

Operating Pressure: 使用压力:0~0.8Mpa 	型号 Model	螺纹尺寸 Port Size	流量孔径 Effective Area	使用温度 Operating Temperature	CV值 CV Value	线圈功率 Coil Power	型式 Type	电压 Voltage	说明 Notes
	2WBF160-15	G1/2	16mm	-5~85℃	4.8	20VA	二口二位 直动式 常闭型 2/2 Way Direct Acting & Normally Closed Type	DC12V DC24V AC24V AC36V AC110V AC220V AC380V	螺纹类型: -PT: PT螺纹 -NPT: NPT 螺纹 -G: G螺纹 Thread Type: -PT: PT Thread -NPT: NPT Thread -G: G Thread
	2WBF200-20	G3/4	20mm	-5~85℃	7.6	20VA			
	2WBF250-25	G1	25mm	-5~85℃	12	20VA			
	2WBF350-35	G1-1/4	35mm	-5~85℃	24	50VA			
	2WBF400-40	G1-1/2	40mm	-5~85℃	29	50VA			
	2WBF500-50	G2	50mm	-5~85℃	48	50VA			

2W系列电磁阀 2W Series Solenoid Valve

Operating Pressure: 使用压力:0~0.8Mpa 	型号 Model	螺纹尺寸 Port Size	流量孔径 Effective Area	使用温度 Operating Temperature	CV值 CV Value	线圈功率 Coil Power	型式 Type	电压 Voltage	说明 Notes
	2W025-06	G1/8	2.5mm	-5~85℃	0.23	15VA	二口二位 直动式 常闭型 2/2 Way Direct Acting & Normally Closed Type	DC12V DC24V AC24V AC36V AC110V AC220V AC380V	螺纹类型: -PT: PT螺纹 -NPT: NPT 螺纹 -G: G螺纹 Thread Type: -PT: PT Thread -NPT: NPT Thread -G: G Thread
	2W025-08	G1/4	2.5mm	-5~85℃	0.23	15VA			
	2W040-10	G3/8	4mm	-5~85℃	0.60	20VA			
	2W160-15	G1/2	16mm	-5~85℃	4.80	20VA			
	2W200-20	G3/4	20mm	-5~85℃	7.60	20VA			
	2W250-25	G1	25mm	-5~85℃	12	20VA			
	2W350-35	G1-1/4	35mm	-5~85℃	24	50VA			
	2W400-40	G1-1/2	40mm	-5~85℃	29	50VA			
2W500-50	G2	50mm	-5~85℃	48	50VA				

2WS防水系列电磁阀 2WS Series Water Proof Solenoid valve

Operating Pressure: 使用压力:0~0.8Mpa 	型号 Model	螺纹尺寸 Port Size	流量孔径 Effective Area	使用温度 Operating Temperature	CV值 CV Value	线圈功率 Coil Power	型式 Type	电压 Voltage	说明 Notes
	2WS025-06	G1/8	2.5mm	-5~85℃	0.23	15VA	二口二位 直动式 常闭型 2/2 Way Direct Acting & Normally Closed Type	DC12V DC24V AC24V AC36V AC110V AC220V AC380V	螺纹类型: -PT: PT螺纹 -NPT: NPT 螺纹 -G: G螺纹 Thread Type: -PT: PT Thread -NPT: NPT Thread -G: G Thread
	2WS025-08	G1/4	2.5mm	-5~85℃	0.23	15VA			
	2WS040-10	G3/8	4mm	-5~85℃	0.60	20VA			
	2WS160-15	G1/2	16mm	-5~85℃	4.80	20VA			
	2WS200-20	G3/4	20mm	-5~85℃	7.60	20VA			
	2WS250-25	G1	25mm	-5~85℃	12	20VA			
	2WS350-35	G1-1/4	35mm	-5~85℃	24	50VA			
	2WS400-40	G1-1/2	40mm	-5~85℃	29	50VA			
2WS500-50	G2	50mm	-5~85℃	48	50VA				

2WA系列电磁阀 2WA Series Solenoid Valve

Operating Pressure: 使用压力:0~0.8Mpa 	型号 Model	螺纹尺寸 Port Size	流量孔径 Effective Area	使用温度 Operating Temperature	CV值 CV Value	线圈功率 Coil Power	型式 Type	电压 Voltage	说明 Notes
	2WA025-06	G1/8	2.5mm	-5~85℃	0.23	15VA	二口二位 先导式 常闭型 2/2 Way Piloted Acting & Normally Closed Type	DC12V DC24V AC24V AC36V AC110V AC220V AC380V	螺纹类型: -PT: PT螺纹 -NPT: NPT 螺纹 -G: G螺纹 Thread Type: -PT: PT Thread -NPT: NPT Thread -G: G Thread
	2WA025-08	G1/4	2.5mm	-5~85℃	0.23	15VA			
	2WA040-10	G3/8	4mm	-5~85℃	0.60	20VA			
	2WA160-15	G1/2	16mm	-5~85℃	4.80	20VA			
	2WA200-20	G3/4	20mm	-5~85℃	7.60	20VA			
	2WA250-25	G1	25mm	-5~85℃	12	20VA			
	2WA350-35	G1-1/4	35mm	-5~85℃	24	50VA			
	2WA400-40	G1-1/2	40mm	-5~85℃	29	50VA			
2WA500-50	G2	50mm	-5~85℃	48	50VA				

2L系列耐高温电磁阀 2L Series Solenoid Valve (High Temperature Resistant Type)

Operating Pressure: 使用压力:0~0.8Mpa 	型号 Model	螺纹尺寸 Port Size	流量孔径 Effective Area	使用温度 Operating Temperature	CV值 CV Value	线圈功率 Coil Power	型式 Type	电压 Voltage	说明 Notes
	2L170-10	G3/8	17mm	-5~185℃	4.80	50VA	二口二位 直动式 常闭型 2/2 Way Direct Acting & Normally Closed Type	DC12V DC24V AC24V AC36V AC110V AC220V AC380V	螺纹类型: -PT: PT螺纹 -NPT: NPT 螺纹 -G: G螺纹 Thread Type: -PT: PT Thread -NPT: NPT Thread -G: G Thread
	2L170-15	G1/2	17mm	-5~185℃	4.80	50VA			
	2L200-20	G3/4	20mm	-5~185℃	7.60	50VA			
	2L250-25	G1	25mm	-5~185℃	12	50VA			
	2L350-35	G1-1/4	35mm	-5~185℃	20	50VA			
	2L400-40	G1-1/2	40mm	-5~185℃	20	50VA			
2L500-50	G2	50mm	-5~185℃	48	50VA				

2WK系列电磁阀 2WK Series Solenoid Valve

Operating Pressure: 使用压力:0~0.8Mpa 	型号 Model	螺纹尺寸 Port Size	流量孔径 Effective Area	使用温度 Operating Temperature	CV值 CV Value	线圈功率 Coil Power	型式 Type	电压 Voltage	说明 Notes
	2WK025-06	G1/8	2.5mm	-5~85℃	0.23	15VA	二口二位 先导式 常开型 2/2 Way Piloted Acting & Normally Open Type	DC12V DC24V AC24V AC36V AC110V AC220V AC380V	螺纹类型: -PT: PT螺纹 -NPT: NPT 螺纹 -G: G螺纹 Thread Type: -PT: PT Thread -NPT: NPT Thread -G: G Thread
	2WK025-08	G1/4	2.5mm	-5~85℃	0.23	15VA			
	2WK040-10	G3/8	4mm	-5~85℃	0.60	20VA			
	2WK160-15	G1/2	16mm	-5~85℃	4.80	20VA			
	2WK200-20	G3/4	20mm	-5~85℃	7.60	20VA			
	2WK250-25	G1	25mm	-5~85℃	12	20VA			
	2WK350-35	G1-1/4	35mm	-5~85℃	24	50VA			
	2WK400-40	G1-1/2	40mm	-5~85℃	29	50VA			
2WK500-50	G2	50mm	-5~85℃	48	50VA				

2WG系列耐高温电磁阀 2WG Series Solenoid Valve (High Temperature Resistant Type)

<p>Operating Pressure: 使用压力:0~0.8Mpa</p> 	型号 Model	螺纹尺寸 Port Size	流量孔径 Effective Area	使用温度 Operating Temperature	CV值 CV Value	线圈功率 Coil Power	型式 Type	电压 Voltage	说明 Notes
	2WG025-06	G1/8	2.5mm	-5~180℃	0.23	15VA	二口二位 先导式 常闭型 2/2 Way Piloted Acting & Normally Closed Type	DC12V DC24V AC24V AC36V AC110V AC220V AC380V	螺纹类型: -PT: PT螺纹 -NPT: NPT 螺纹 -G: G螺纹 Thread Type: -PT: PT Thread -NPT: NPT Thread -G: G Thread
	2WG025-08	G1/4	2.5mm	-5~180℃	0.23	15VA			
	2WG040-10	G3/8	4mm	-5~180℃	0.60	20VA			
	2WG160-15	G1/2	16mm	-5~180℃	4.80	20VA			
	2WG200-20	G3/4	20mm	-5~180℃	7.60	20VA			
	2WG250-25	G1	25mm	-5~180℃	12	20VA			
	2WG350-35	G1-1/4	35mm	-5~180℃	24	50VA			
	2WG400-40	G1-1/2	40mm	-5~180℃	29	50VA			
2WG500-50	G2	50mm	-5~180℃	48	50VA				

PU220系列电磁阀 PU220 Series Solenoid Valve

<p>Operating Pressure: 使用压力:0~0.8Mpa</p> 	型号 Model	螺纹尺寸 Port Size	流量孔径 Effective Area	使用温度 Operating Temperature	CV值 CV Value	线圈功率 Coil Power	型式 Type	电压 Voltage	说明 Notes
	PU220-01	G1/8	1.5mm	-5~85℃	0.10	22VA	二口二位 直动式 常闭型 2/2 Way Direct Acting & Normally Closed Type	DC12V DC24V AC24V AC36V AC110V AC220V AC380V	螺纹类型: -PT: PT螺纹 -NPT: NPT 螺纹 -G: G螺纹 Thread Type: -PT: PT Thread -NPT: NPT Thread -G: G Thread
	PU220-02	G1/4	2.3mm	-5~85℃	0.18	22VA			
	PU220-03	G3/8	8mm	-5~85℃	1.00	22VA			
	PU220-04	G1/2	13mm	-5~85℃	4.00	22VA			
	PU220-06	G3/4	20mm	-5~85℃	8.60	22VA			
PU220-08	G1	25mm	-5~85℃	11.0	22VA				

PU225系列电磁阀 PU225 Series Solenoid Valve

<p>Operating Pressure: 使用压力:0~0.8Mpa</p> 	型号 Model	螺纹尺寸 Port Size	流量孔径 Effective Area	使用温度 Operating Temperature	CV值 CV Value	线圈功率 Coil Power	型式 Type	电压 Voltage	说明 Notes
	PU225-03	G3/8	25mm	-5~85℃	12	22VA	二口二位 先导式 常闭型 2/2 Way Piloted Acting & Normally Closed Type	DC12V DC24V AC24V AC36V AC110V AC220V AC380V	螺纹类型: -PT: PT螺纹 -NPT: NPT 螺纹 -G: G螺纹 Thread Type: -PT: PT Thread -NPT: NPT Thread -G: G Thread
	PU225-04	G1/2	25mm	-5~85℃	12	22VA			
	PU225-06	G3/4	38mm	-5~85℃	22	22VA			
PU225-08	G1	38mm	-5~85℃	30	22VA				

VX系列通电磁阀 VX Series Solenoid Valve

<p>Operating Pressure: 使用压力:0~0.8Mpa</p> 	型号 Model	螺纹尺寸 Port Size	流量孔径 Effective Area	使用温度 Operating Temperature	型式 Type	电压 Voltage	说明 Notes
	VX2120-06	G1/8	3mm	-5~85℃	二口二位 直动式 常闭型 2/2 Way Direct Acting & Normally Closed Type	DC12V DC24V AC24V AC36V AC110V AC220V AC380V	螺纹类型: -PT: PT螺纹 -NPT: NPT 螺纹 -G: G螺纹 Thread Type: -PT: PT Thread -NPT: NPT Thread -G: G Thread
	VX2120-08	G1/4	3mm	-5~85℃			
	VX2120-10	G3/8	13mm	-5~85℃			
VX2120-15	G1/2	13mm	-5~85℃				

2Q系列气控阀 2Q Series Air Control Valve

<p>Operating Pressure: 使用压力:0~0.8Mpa</p> 	型号 Model	螺纹尺寸 Port Size	流量孔径 Effective Area	使用温度 Operating Temperature	型式 Type	电压 Voltage	说明 Notes
	2Q200-20	G3/4	22mm	-5~85℃	二位二通 直动式 常闭型 2/2 Way Direct Acting & Normally Closed Type	DC12V DC24V AC24V AC36V AC110V AC220V AC380V	螺纹类型: -PT: PT螺纹 -NPT: NPT 螺纹 -G: G螺纹 Thread Type: -PT: PT Thread -NPT: NPT Thread -G: G Thread
	2Q200-25	G1	22mm	-5~85℃			
	2Q350-35	G1-1/4	35mm	-5~85℃			
2Q500-50	G2	50mm	-5~85℃				

2WBB系列电磁阀 2WBB Series Solenoid Valve

<p>Operating Pressure: 使用压力:0~0.8Mpa</p> 	型号 Model	螺纹尺寸 Port Size	流量孔径 Effective Area	使用温度 Operating Temperature	CV值 CV Value	线圈功率 Coil Power	型式 Type	电压 Voltage	说明 Notes
	2WBB160-15	G1/2	16mm	-5~85℃	4.8	20VA	二口二位 直动式 常闭型 2/2 Way Direct Acting & Normally Closed Type	DC12V DC24V AC24V AC36V AC110V AC220V AC380V	螺纹类型: -PT: PT螺纹 -NPT: NPT 螺纹 -G: G螺纹 Thread Type: -PT: PT Thread -NPT: NPT Thread -G: G Thread
	2WBB200-20	G3/4	20mm	-5~85℃	7.6	20VA			
	2WBB250-25	G1	25mm	-5~85℃	12	20VA			
	2WBB350-35	G1-1/4	35mm	-5~85℃	24	50VA			
	2WBB400-40	G1-1/2	40mm	-5~85℃	29	50VA			
2WBB500-50	G2	50mm	-5~85℃	48	50VA				

Q22\Q23系列电磁阀 Q22\Q23 Seires Solenoid Valve

Operating Pressure: 使用压力:0~0.8Mpa	型号 Model	螺纹尺寸 Port Size	流量孔径 Effective Area	使用温度 Operating Temperature	CV值 CV Value	线圈功率 Coil Power	型式 Type	电压 Voltage
	Q22XD-2L	G1/8	2.0mm	-5~85℃	0.23	15VA	二口二位 常闭式 2/2Way Normally Closed	DC12V DC24V AC24V AC36V
	Q22XD-3L	G1/8	3.0mm	-5~85℃	0.40	15VA		
	Q23XD-2L	G1/8	2.0mm	-5~85℃	0.23	15VA	三口二位 常闭式 3/2Way Normally Closed	AC110V AC220V AC380V
	Q23XD-3L	G1/8	3.0mm	-5~85℃	0.40	15VA		

OPT-A/B系列电子排水阀 OPT-A/B Electronic Drain Valve

Operating Pressure: 使用压力:0~0.8Mpa	型号 Model	螺纹尺寸 Port Size	结构 Structure	间隔时间 Interval Time	排放时间 Discharge Time	使用温度 Operating Temperature	电压 Voltage	说明 Notes
	OPT-A	G1/2	分体型 Split Type	0.5-45分钟 (Mins)	0.5-10秒 (Seconds)	0~90℃	DC12V DC24V DC36V AC36V AC110V AC220V AC380V	螺纹类型: -PT: PT螺纹 -NPT: NPT 螺纹 -G: G螺纹 Thread Type: -PT: PT Thread -NPT: NPT Thread -G: G Thread
OPT-B	G1/2	连体型 Connected Type	0.5-45分钟 (Mins)	0.5-10秒 (Seconds)				

SCG系列电磁阀 SCG Series Solenoid Valve

Operating Pressure: 使用压力:0~0.8Mpa	型号 Model	螺纹尺寸 Port Size	使用温度 Operating Temperature	型式 Type	线圈 Coil	电压 Voltage	说明 Notes
	SCG-331	G1/4	-5~55℃	五口二位 & 三口二位 先导式	A01: 单线圈 A02: 双线圈	DC12V DC24V DC36V AC36V AC110V AC220V AC380V	螺纹类型: -PT: PT螺纹 -NPT: NPT 螺纹 -G: G螺纹 Thread Type: -PT: PT Thread -NPT: NPT Thread -G: G Thread
	SCG-531	G1/4	-5~55℃				
	SCG-551	G1/4	-5~55℃	5/2 Way & 3/2 Way Piloted Acting Type			
	SCG-553	G1/4	-5~55℃				

2VT系列电磁阀 2VT Series Solenoid Valve

Operating Pressure: 使用压力:0~0.8Mpa	型号 Model	螺纹尺寸 Port Size	流量孔径 Effective Area	使用温度 Operating Temperature	CV值 CV Value	线圈功率 Coil Power	型式 Type	电压 Voltage	说明 Notes
	2VT-06	G1/8	2.5mm	-5~85℃	0.23	3VA	二口二位 常闭式 2/2 Way Normally Closed	DC12V DC24V DC36V AC36V AC110V AC220V AC380V	螺纹类型: -PT: PT螺纹 -NPT: NPT 螺纹 -G: G螺纹 Thread Type: -PT: PT Thread -NPT: NPT Thread -G: G Thread
	2VT-08	G1/4	2.5mm	-5~85℃	0.23	3VA			
	2VT-10	G3/8	4.0mm	-5~85℃	0.60	3VA			
	2VT-15	G1/2	16mm	-5~85℃	4.80	3VA			
	2VT-20	G3/4	20mm	-5~85℃	7.60	3VA			
	2VT-25	G1	25mm	-5~85℃	12	3VA			

2WF/FB2E/DC231系列电磁阀 2WF/FB2E/DC231 Series Solenoid Valve

Operating Pressure: 使用压力:0~0.8Mpa	型号 Model	螺纹尺寸 Port size	流量孔径 Effective area	使用温度 Operating Temperature	CV值 CV value	线圈功率 Coil power	型式 Type	电压 Voltage	说明 Notes
	2WF	G1/2	16mm	-5~85℃	4.80	20VA	二口二位 2/2Way	DC12V DC24V AC24V AC36V AC110V AC220V AC380V	螺纹类型: -PT: PT螺纹 -NPT: NPT 螺纹 -G: G螺纹 Thread Type: -PT: PT Thread -NPT: NPT Thread -G: G Thread
	FB2E-V	G1/4	3.5mm	-5~85℃	0.23	15VA			
	DC231-Y	G1/4	1.6mm	-5~85℃	0.23	15VA	三口二位 3/2 Way		

LT23JD系列电磁阀 LT23JD Series Solenoid Valve

Operating Pressure: 使用压力:0~2.4Mpa	型号 Model	螺纹尺寸 Port Size	有效截面积 Orifice Size	使用温度 Operating Temperature	换向时间 Conversion Time	型式 Type	电压 Voltage	说明 Notes
	LT23JD-08	G1/4	20mm ²	-5~55℃	0.04S	空白: 内部先导式 P2: 外部先导 Acting Type Blank: Inner Piloted P2: Outer Piloted Acting Type	DC12V DC24V DC36V AC36V AC110V AC220V AC380V	螺纹类型: -PT: PT螺纹 -NPT: NPT 螺纹 -G: G螺纹 Thread Type: -PT: PT Thread -NPT: NPT Thread -G: G Thread
	LT23JD-15	G1/2	60mm ²	-5~55℃	0.08S			
	LT23JD-08-P2	G1/4	20mm ²	-5~55℃	0.04S			
	LT23JD-15-P2	G1/2	60mm ²	-5~55℃	0.08S			

A系列气控阀 A Series Air Control Valve

Operating Pressure: 使用压力:0~0.8Mpa	型号 Model	螺纹尺寸 Port Size	有效截面积 Orifice Size	使用温度 Operating Temperature	CV值 CV Value	控制型式 Control Type	阀型 Valve Type	说明 Notes
	A-01	G1/8	16mm ²	-5~55℃	0.89	手动复位式 Hand Return	五口二位 5/2 Way	螺纹类型: -PT: PT螺纹 -NPT: NPT 螺纹 -G: G螺纹 Thread Type: -PT: PT Thread -NPT: NPT Thread -G: G Thread
	A-02	G1/4						
	A-03	G3/4						

HFS系列控制阀 HFS Series Control Valve

Operating Pressure: 使用压力:0~0.8Mpa 	型号 Model	螺纹尺寸 Port Size	最大流量 Max. Rated Flow	使用温度 Operating Temperature	建议用油 Recommended Oil	选项/说明 Notes
	HFS-15	G1/2	650L/min	-5~55℃	ISO VG32透平1号油 ISO VG32 No.1 Turbine Oil	螺纹类型: -PT: PT螺纹 -NPT: NPT 螺纹 -G: G螺纹
	HFS-20	G3/4	750L/min	-5~55℃	最高液体温度100℃ Max. Liquid Temperature 100℃	Thread Type: -PT: PT Thread -NPT: NPT Thread -G: G Thread
	HFS-25	G1	1000L/min	-5~55℃		

BV系列安全阀 BV Series Safety Valves

Operating Pressure: 使用压力:0~0.8Mpa 	型号 Model	型号 Model	泄荷压力 Setting Pressure	使用温度 Operating Temperature Range	说明 Notes
	BV-01-2 PT1/8	BV-03-2 PT3/8	0.2Mpa	-5~85℃	螺纹类型: -PT: PT螺纹 -NPT: NPT 螺纹 -G: G螺纹 Thread Type: -PT: PT Thread -NPT: NPT Thread -G: G Thread
	BV-01-4 PT1/8	BV-03-4 PT3/8	0.4Mpa	-5~85℃	
	BV-01-7 PT1/8	BV-03-7 PT3/8	0.7Mpa	-5~85℃	
	BV-01-10 PT1/8	BV-03-10 PT3/8	1.0Mpa	-5~85℃	
	BV-02-2 PT1/4	BV-04-2 PT1/2	0.2Mpa	-5~85℃	
	BV-02-4 PT1/4	BV-04-4 PT1/2	0.4Mpa	-5~85℃	
	BV-02-7 PT1/4	BV-04-7 PT1/2	0.7Mpa	-5~85℃	
BV-02-10 PT1/4	BV-04-10 PT1/2	1.0Mpa	-5~85℃		

K系列滑柱式换向阀 K Series Control Change Solenoid Valve

Operating Pressure: 使用压力:0~0.8Mpa 	型号 Model	螺纹尺寸 Port Size	流量孔径 Effective Area	使用温度 Operating Temperature	控制方式 Control Type	型式 Type	电压 Voltage	说明 Notes
	K25D-6	G1/8	6mm	-5~55℃	K25D:单线圈 K25D2:双线圈 K25K:单气控 K25K2:双气控	五口二位 5/2Way	DC12V DC24V AC24V AC36V AC110V AC220V AC380V	螺纹类型: -PT: PT螺纹 -NPT: NPT 螺纹 -G: G螺纹 Thread Type: -PT: PT Thread -NPT: NPT Thread -G: G Thread
	K25D-8	G1/4	8mm	-5~55℃				
	K25D-10	G3/8	10mm	-5~55℃				
	K25D-15	G1/2	15mm	-5~55℃				
	K25D-20	G3/4	20mm	-5~55℃	K25D: Single Coil K25D2: Double Coil K25K: Single Air Control K25K2: Double Air Control			
	K25D-25	G1	25mm	-5~55℃				
	K25D-30	G1-1/4	30mm	-5~55℃				
	K25D-40	G1-1/2	40mm	-5~55℃				
	K25D-50	G2	50mm	-5~55℃				

VHS系列残压释放阀 VHS Series Pressure Relief Valve

Operating Pressure: 使用压力: 0~0.8Mpa 	型号 Model	进出螺纹尺寸 Inlet & Outlet Port Size	泄荷螺纹尺寸 Exhaust Port Size	使用温度 Operating Temperature	适用型号 Applicable Model	说明 Notes
	VHS20-01	PT1/8	PT1/8	-5~55℃	AC2010	螺纹类型: -PT: PT螺纹 -NPT: NPT 螺纹 -G: G螺纹 Thread Type: -PT: PT Thread -NPT: NPT Thread -G: G Thread
	VHS20-02	PT1/4	PT1/8	-5~55℃	AC2010	
	VHS30-02	PT1/4	PT1/4	-5~55℃	AC3010	
	VHS30-03	PT3/8	PT1/4	-5~55℃	AC3010	
	VHS40-02	PT1/4	PT3/8	-5~55℃	AC4010	
	VHS40-03	PT3/8	PT3/8	-5~55℃	AC4010	
	VHS40-04	PT1/2	PT3/8	-5~55℃	AC4010	
	VHS40-06	PT3/4	PT1/2	-5~55℃	AC4010-06	
	VHS50-06	PT3/4	PT1/2	-5~55℃	AC5010	
VHS50-10	PT1	PT1/2	-5~55℃	AC5010		

QPM/QPF-1系列压力开关 QPM/QPF-1 Series Pressure Control Switch

Operating Pressure: 使用压力:0~0.8Mpa 	型号 Model	螺纹接口 Port Size	最低闭合压力 Min Closed Pressure	最高断开压力 Max. Open Pressure	差压调节范围 Adjustable Pressure Range	出厂设定 Leave Factory Set	型式 Type	说明 Notes
	QPM11-NO-01	PT1/8	0.02MPa	0.07MPa	0.02~0.6MPa	0.04MPa	NO:常开 NO:Normally Open	螺纹类型: -PT: PT螺纹 -NPT: NPT 螺纹 -G: G螺纹 Thread Type: -PT: PT Thread -NPT: NPT Thread -G: G Thread
	QPM11-NO-02	PT1/4	0.02MPa	0.07MPa	0.02~0.7MPa	0.04MPa		
	QPM11-NC-01	PT1/8	0.02MPa	0.07MPa	0.02~0.6MPa	0.04MPa	NC:常闭 NC:Normally Closed	
	QPM11-NC-02	PT1/4	0.02MPa	0.07MPa	0.02~0.7MPa	0.04MPa		
	QPF-1	PT1/8	0.02MPa	0.07MPa	0.02~0.6MPa	0.04MPa	常开常闭一体式 Both Normally Open and Normally Closed Type	
	QPF-2	PT1/4	0.02MPa	0.07MPa	0.02~0.6MPa	0.04MPa		
	QPF-3	PT3/8	0.02MPa	0.07MPa	0.02~0.6MPa	0.04MPa		

CBP系列单压开关 CBP Series Single Pressure Control Switch

Operating Pressure: 使用压力:0~0.8Mpa	型号 Model	压力范围 Pressure Range(Bar)	差压 Differential Pressure(Bar)	出厂设定 Factory Setting(Bar)		最大气密试验压力 Max. Gas Tight Test Pressure(Bar)
				Fig.1	Fig.2	
	CBP502	-0.5~2	0.2~0.7	1	0.5	16.5
	CBP503	-0.5~3	0.35~1.5	2	1	16.5
	CBP506	-0.5~6	0.6~4	3	2	16.5
	CBP506M	-0.5~5.5	≤1	手动复位 Manual Reset	3	16.5
	CBP110	1~10	1~3	6	5	16.5
	CBP516	5~16	2~5	10	8	33
	CBP520	5~20	2~5	16	14	33
	CBP530D	5~30	3~10	20	15	33
	CBP530	8~30	3~5固定 Fixation	20	15~17	33
	CBP503M	8~30	≤5	20	手动复位 Manual Reset	33

CBP系列双压开关 CBP Series Double Pressure Control Switch

Operating Pressure: 使用压力:0~0.8Mpa	型号 Model	低压 Low Pressure		高压 High Pressure		出厂设定 Factory Setting(Bar)			
		压力范围 Pressure Range(Bar)	差压 Differential Pressure(Bar)	压力范围 Pressure Range(Bar)	差压 Differential Pressure(Bar)	Fig.1 Fig.2 Fig.1 Fig.2			
						Fig.1	Fig.2	Fig.1	Fig.2
	CBP803	-0.5~6	0.6~4	8~30	3~5固定 Fixation	3	2	20	15
	CBP830HM	-0.5~6	0.6~4	8~30	≤5	3	2	20	手动 Manual
	CBP830	-0.5~5.5	≤1	8~30	≤5	手动 Manual	3	20	手动 Manual

PS系列压力开关 PS Series Pressure Control Switch

Operating Pressure: 使用压力:0~0.8Mpa	型号 Model	最低闭合压力 Min. Closed Pressure	最高断开压力 Max. Open Pressure	差压调节范围 Adjustable Pr- essure Range	出厂设定 Leave Factory Set	额定电压电流 Rated Voltage Rated Ampere	额定电压电流 Rated Voltage Rated Ampere	螺纹接口 Port Size	说明 Notes
	PS10-1H1	2.0kgf/cm ²	7.0kgf/cm ²	1.5~2.5kgf/cm ²	4.0~5.5kgf/cm ²	110V,20A	220V,12A	G1/4	螺纹类型: -PT: PT螺纹 -NPT: NPT 螺纹 -G: G螺纹 Thread Type: -PT: PT Thread -NPT: NPT Thread -G: G Thread
	PS10-1H2	2.5kgf/cm ²	10.5kgf/cm ²	2.0~3.0kgf/cm ²	6.0~8.0kgf/cm ²	110V,20A	220V,12A	G1/4	
	PS10-1H3	3.5kgf/cm ²	12.5kgf/cm ²	2.5~3.5kgf/cm ²	7.0~10kgf/cm ²	110V,20A	220V,12A	G1/4	
	PS10-4H1	2.0kgf/cm ²	7.0kgf/cm ²	1.5~2.5kgf/cm ²	4.0~5.5kgf/cm ²	110V,20A	220V,12A	G1/4	
	PS10-4H2	2.5kgf/cm ²	10.5kgf/cm ²	2.0~3.0kgf/cm ²	6.0~8.0kgf/cm ²	110V,20A	220V,12A	G1/4	
	PS10-4H3	3.5kgf/cm ²	12.5kgf/cm ²	2.5~3.5kgf/cm ²	7.0~10kgf/cm ²	110V,20A	220V,12A	G1/4	

RNS系列压力开关 RNS Series Pressure Control Switch

Operating Pressure: 使用压力:0~0.8Mpa	型号 Model	螺纹接口 Port Size	最低闭合压力 Min. Closed Pressure	最高断开压力 Max. Open Pressure	差压调节范围 Adjustable Pr- essure Range	出厂设定 Leave Factory Set	额定电压电流 Rated Voltage Rated Ampere	额定电压电流 Rated Voltage Rated Ampere	说明 Notes
	RNS-103	M11×1.25	0.01kgf/cm ²	3kgf/cm ²	0.5~1.5kgf/cm ²	0.5~1.5kgf/cm ²	110V,20A	220V,12A	螺纹类型: -PT: PT螺纹 -NPT: NPT 螺纹 -G: G螺纹 Thread Type: -PT: PT Thread -NPT: NPT Thread -G: G Thread
	RNS-106	M11×1.25	1.0kgf/cm ²	6kgf/cm ²	0~3.0kgf/cm ²	1.0~3.0kgf/cm ²	110V,20A	220V,12A	
	RNS-110	M11×1.25	1kgf/cm ²	9kgf/cm ²	0~3.0kgf/cm ²	4.0~6.0kgf/cm ²	110V,20A	220V,12A	
	RNS-120	M11×1.25	1.5kgf/cm ²	17kgf/cm ²	0~5kgf/cm ²	12~15kgf/cm ²	110V,20A	220V,12A	
	RNS-130	M11×1.25	3kgf/cm ²	25kgf/cm ²	0~5kgf/cm ²	15~20kgf/cm ²	110V,20A	220V,12A	

HSV系列滑动开关 HSV Series Hand Slide Valve

Operating Pressure: 使用压力:0~0.8Mpa	型号 Model	螺纹尺寸 Port Size	使用温度 Operating Temperature	螺纹型式 Port Type	使用流体 Fluid	阀型 Valve Type	材质 Material	说明 Notes
	HSV-06	G1/8	-5~55℃	MM: 双外牙 MF: 内外牙 FF: 双内牙	空气 Air	五口二位 5/2 Way	-A: 铝合金 -B: 铜	螺纹类型: -PT: PT螺纹 -NPT: NPT 螺纹 -G: G螺纹 Thread Type: -PT: PT Thread -NPT: NPT Thread -G: G Thread
	HSV-08	G1/4	-5~55℃					
	HSV-10	G3/8	-5~55℃					
	HSV-15	G1/2	-5~55℃					

HL/SHL系列钮子开关 HL/SHL Series Toggle Switch

Operating Pressure: 使用压力:0~0.8Mpa	型号 Model	螺纹尺寸 Port Size	有效截面积 Orifice Size	使用温度 Operating Temperature	CV值 CV Value	阀型 Valve Type	控制型式 Control Type	说明 Notes	
									G1/8
	HL-2301	G1/8	16mm ²	-5~55℃	0.89	三口二位 3/2 Way	手动复位式 Hand-Operated Return Back 常闭型 Normally Closed Type	螺纹类型: -PT: PT螺纹 -NPT: NPT 螺纹 -G: G螺纹 Thread Type: -PT: PT Thread -NPT: NPT Thread -G: G Thread	
	HL-2501	G1/8	16mm ²	-5~55℃	0.89	五口二位 5/2 Way			
	SHL-01	G1/8	16mm ²	-5~55℃	0.89	三口二位 3/2 Way			

AV系列直动式电磁阀 AV Series Solenoid Valve	型号 Model	螺纹尺寸 Port Size
	AV21-01	PT1/8
	AV21-02	PT1/4
	AV21-03	PT3/8
	AV21-04	PT1/2
	AV21-06	PT3/4
	AV21-08	PT1"

TXTJF系列常闭直动式电磁阀 TXTJF Series Solenoid Valve	型号 Model	螺纹尺寸 Port Size
	TXTJF-01	G1/8
	TXTJF-02	G1/4
	TXTJF-03	G3/8
	TXTJF-04	G1/2
	TXTJF-06	G3/4
	TXTJF-08	G1"

TX2120系列常闭直动式电磁阀 TX2120 Series High Pressure Solenoid Valve	型号 Model	螺纹尺寸 Port Size
	TX2120-01	G1/8
	TX2120-02	G1/4
	TX2120-03	G3/8
	TX2120-04	G1/2
	TX2120-06	G3/4
	TX2120-08	G1"

5404系列高压系列电磁阀 5404 Series High Pressure Solenoid Valve	型号 Model	螺纹尺寸 Port Size
	5401-01	G1/8
	5404-02	G1/4
	5404-03	G3/8
	5404-04	G1/2
	5404-06	G3/4
	5404-08	G1

6213系列电磁阀 6213 Series Solenoid Valve	型号 Model	螺纹尺寸 Port Size
	6213-01	G1/8
	6213-02	G1/4
	6213-03	G3/8
	6213-04	G1/2
	6213-06	G3/4
	6213-08	G1

0927系列电磁阀 0927 Series Solenoid Valve	型号 Model	螺纹尺寸 Port Size
	0927000	8MM
	0927100	10MM
	0927200	12MM
	0927300	20MM
	0927400	25MM
	0927500	32MM
	0927600	40MM
	0927700	50MM

NS系列氮气弹簧 NS Series Nitrogen Spring	型号 Model	
	NS750-10	NS750-50
	NS750-13	NS750-63
	NS750-16	
	NS750-19	
	NS750-25	
	NS750-32	
	NS750-38	

CPR系列二氧化碳调压阀 CPR Series Pressure Regulator	型号 Model	
	CPR-01	
	CPR-02	
	CPR-03	
	CPR-04	
	CPR-06	
	CPR-08	

DBF系列空压蝶式制动器 DBF Series Air Clutches Brake	型号 Model	
	DBF-08	
	DBF-10	
	DBF-15	

K22JD系列截止阀 K22JD Series Cut-off Valve	型号 Model	
	K22JD-8W	
	K22JD-10W	
	K22JD-15W	
	K22JD-20W	
	K22JD-25W	
	K22JD-32W	
	K22JD-40W	

K23JD系列截止阀 K23JD Series Cut-off Valve	型号 Model	
	K23JD-8W	
	K23JD-10W	
	K23JD-15W	
	K23JD-20W	
	K23JD-25W	
	K23JD-32W	
	K23JD-40W	

K25JK系列气控阀 K25JK Series Air Control Valve	型号 Model	
	K25JK-8W	
	K25JK-10W	
	K25JK-15W	
	K25JK-20W	
	K25JK-25W	
	K25JK-32W	

R系列振动器 R Series Vibrator	型号 Model	
	R-50	
	R-65	
	R-80	

K系列振动器 K Series Vibrator	型号 Model	
	K-08	K-20
	K-10	K-25
	K-13	K-32
	K-16	K-36

GT系列振动器 GT Series Vibrator	型号 Model	
	GT-08	GT-36
	GT-10	GT-40
	GT-13	GT-48
	GT-16	GT-65
	GT-20	
	GT-25	
	GT-32	

TK-10系列压力控制器 TK-10 Pressure Controller

适用型号 Applicable Model
TK-10
TK-15
TK-20

ZSE系列压力开关 ZSE Pressure Control Switch

适用型号 Applicable Model
ZSE30A-01-N
ZSE30AF-01-N

PIC-20X型脉冲喷吹控制仪 PIC-20X Pulse Valve Controller

适用型号 Applicable Model
DF-40F
DF-50F
DF-65F
DF-80F
DF-100F

SK系列敲击锤 SK Series Air Hammer

适用型号 Applicable Model
SK-30
SK-40
SK-60
SK-80

3V系列汇流板(亚德客型) 3V Series Manifold (AirTac Type)

型号 Model	集装位数 Stations
100M:PT1/4	1F-13F
200M:PT1/4	1F-13F
300M:PT3/8	1F-13F

4V系列汇流板(亚德客型) 4V Series Manifold (AirTac Type)

型号 Model	集装位数 Stations
100M:PT1/4	1F-13F
200M:PT1/4	1F-13F
300M:PT3/8	1F-13F
400M:PT1/2	1F-13F

M系列汇流板(小金井型) M Series Manifold (Koganei Type)

型号 Model	集装位数 Stations
M062	1F-17F
M100	1F-17F
M125	1F-17F
M126	1F-17F
M200	1F-17F
M254	1F-17F

VF系列汇流板(SMC型) VF Series Manifold (SMC Type)

型号 Model	集装位数 Stations
VF1000	1F-17F
VF3000	1F-17F
VF5000	1F-17F

VQZ系列汇流板(SMC型) VQZ Series Manifold (SMC Type)

型号 Model	集装位数 Stations
VQZ100	1F-17F
VQZ200	1F-17F
VQZ300	1F-17F

SY系列汇流板(SMC型) SY Series Manifold (SMC Type)

型号 Model	集装位数 Stations
SY3:PT1/4	1F-17F
SY5:PT1/4	1F-17F
SY7:PT3/8	1F-17F

SV系列汇流板(气立可型) SV Series Manifold (Chelic Type)

型号 Model	集装位数 Stations
SV500	1F-13F
SV600	1F-13F
SV800	1F-13F
SV900	1F-13F

PMB系列汇流板(气立可型) PMB Series Manifold (Chelic Type)

型号 Model	集装位数 Stations
PMB110	1F-13F
PMB220	1F-13F
PMB330	1F-13F

MVSC系列汇流板(金器型) MVSC Series Manifold (MindMan Type)

型号 Model	集装位数 Stations
MVSC220	1F-17F
MVSC260	1F-17F
MVSC300	1F-17F
MVSC460	1F-17F

L系列汇流板(FESTO型) L Series Manifold (FESTO Type)

型号 Model	集装位数 Stations
L1	1F-17F
L2	1F-17F
L12	1F-17F
L22	1F-17F

VABM系列汇流板(FESTO型) VABM Series Manifold (FESTO Type)

型号 Model	集装位数 Stations
PMB110	1F-13F
PMB220	1F-13F
PMB330	1F-13F

355系列汇流板(ASCO型) 355 Series Manifold (ASCO Type)

型号 Model	集装位数 Stations
M520	1F-17F
M521	1F-17F
M531	1F-17F

KV系列汇流板(SYM型) KV Series Manifold (SYM Type)

型号 Model	集装位数 Stations
KV110	1F-13F
KV210	1F-13F
KV310	1F-13F

PHS系列汇流板(Parker型) PHS Series Manifold (Parker Type)

型号 Model	集装位数 Stations
PHS320	1F-13F
PHS520	1F-13F
PHS530	1F-13F
PHS540	1F-13F

TZ系列汇流板(NOK型) TZ Series Manifold (NOK Type)

型号 Model	集装位数 Stations
TZ511	1F-13F
TZ522	1F-13F

4GD系列汇流板(CKD型) 4GD Series Manifold (CKD Type)

型号 Model	集装位数 Stations
4GD110	1F-17F
4GD119	1F-17F
4GD210	1F-17F
4GD219	1F-17F
4GD310	1F-17F
4GD319	1F-17F

4V系列盲板(亚德客型) 4V Series Plank Plate (AirTac Type)

型号 Model	集装位数 Stations
100M	1F-13F
200M	1F-13F
300M	1F-13F
400M	1F-13F

SY系列盲板(SMC型) SY Series Plank Plate (SMC Type)

型号 Model	集装位数 Stations
SY3	1F-17F
SY5	1F-17F
SY7	1F-17F

气动阀配件 Pneumatic Valve Accessory



DMF膜片
 DMF Diaphragm



DMF膜片
 DMF Diaphragm



DMF膜片
 DMF Diaphragm

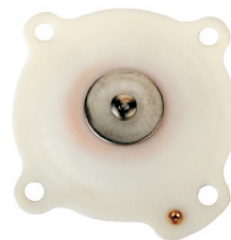

DMF膜片
 DMF Diaphragm



2W-15膜片
 2W-15 Diaphragm



2W-25膜片
 2W-25 Diaphragm



2W-40膜片
 2W-40 Diaphragm



2W-50膜片
 2W-50 Diaphragm



2W-15先导头
 2W-15 Pilot Head



2W-50先导头
 2W-50 Pilot Head



US-15先导头
 US-15 Pilot Head



US-40先导头
 US-40 Pilot Head



US-50先导头
 US-50 Pilot Head



DMF-A-25先导头
 DMF-A-25 Pilot Head



DMF-A-40先导头
 DMF-A-40 Pilot Head



DMF-Z-25先导头
 DMF-Z-25 Pilot Head



DMF-D-25先导头
 DMF-D-25 Pilot Head



DMF-Z-40先导头
 DMF-Z-40 Pilot Head



US-15活塞
 US-15 Piston



US-25活塞
 US-25 Piston



US-40活塞
 US-40 Piston



US-50活塞
 US-50 Piston



产品名称 Product Name:2W-8
 线圈孔径高度 Coil Dia. & Height:Φ14×31
 电压 Voltage:AC12V~220V DC12V~24V
 线圈防护等级 Coil Protection:IP65



产品名称 Product Name:2W-15
 线圈孔径高度 Coil Dia. & Height:Φ16×37
 电压 Voltage:AC12V~220V DC12V~24V
 线圈防护等级 Coil Protection:IP65



产品名称 Product Name:US
 线圈孔径高度 Coil Dia. & Height:Φ23×55
 电压 Voltage:AC12V~220V DC12V~24V
 线圈防护等级 Coil Protection:IP65



产品名称 Product Name:KSD
 线圈孔径高度 Coil Dia. & Height:Φ13.5×26
 电压 Voltage:AC12V~220V DC12V~24V
 线圈防护等级 Coil Protection:IP65



产品名称 Product Name:AV21-01
 线圈孔径高度 Coil Dia. & Height:Φ11.5×37
 电压 Voltage:AC12V~220V DC12V~24V
 线圈防护等级 Coil Protection:IP65



产品名称 Product Name:AV21-02
 线圈孔径高度 Coil Dia. & Height:Φ13.5×30.5
 电压 Voltage:AC12V~220V DC12V~24V
 线圈防护等级 Coil Protection:IP65



1381防爆线圈/1381 Explosion Proof Coil
 线圈孔径高度 Coil Dia. & Height:Φ13×43
 电压 Voltage:AC12V~220V DC12V~24V
 线圈防护等级 Coil Protection:IP65



1681防爆线圈/1681 Explosion Proof Coil
 线圈孔径高度 Coil Dia. & Height:Φ16×43
 电压 Voltage:AC12V~220V DC12V~24V
 线圈防护等级 Coil Protection:IP65



2081防爆线圈/2081 Explosion Proof Coil
 线圈孔径高度 Coil Dia. & Height:Φ20×63
 电压 Voltage:AC12V~220V DC12V~24V
 线圈防护等级 Coil Protection:IP65



产品名称 Product Name:CY123
 线圈孔径高度 Coil Dia. & Height:Φ23×38.5
 电压 Voltage:AC12V~220V DC12V~24V
 线圈防护等级 Coil Protection:IP65



产品名称 Product Name:0545
 线圈孔径高度 Coil Dia. & Height:Φ14.5×42
 电压 Voltage:AC12V~220V DC12V~24V
 线圈防护等级 Coil Protection:IP65



产品名称 Product Name:BD-A
 线圈孔径高度 Coil Dia. & Height:Φ18.5×41.5
 电压 Voltage:AC12V~220V DC12V~24V
 线圈防护等级 Coil Protection:IP65



产品名称 Product Name:DMF
 线圈孔径高度 Coil Dia. & Height:Φ23×38.5
 电压 Voltage:AC12V~220V DC12V~24V
 线圈防护等级 Coil Protection:IP65



产品名称 Product Name:A044
 线圈孔径高度 Coil Dia. & Height:Φ14.5×42
 电压 Voltage:AC12V~220V DC12V~24V
 线圈防护等级 Coil Protection:IP65



产品名称 Product Name:A051
 线圈孔径高度 Coil Dia. & Height:Φ18.5×41.5
 电压 Voltage:AC12V~220V DC12V~24V
 线圈防护等级 Coil Protection:IP65



US防爆线圈/US Water Proof Coil
 线圈孔径高度 Coil Dia. & Height:Φ13×43
 电压 Voltage:AC12V~220V DC12V~24V
 线圈防护等级 Coil Protection:IP65



产品名称 Product Name:CKD Type
 线圈孔径高度 Coil Dia. & Height:Φ16×38
 电压 Voltage:AC12V~220V DC12V~24V
 线圈防护等级 Coil Protection:IP65



产品名称 Product Name:0200
 线圈孔径高度 Coil Dia. & Height:Φ13×41
 电压 Voltage:AC12V~220V DC12V~24V
 线圈防护等级 Coil Protection:IP65



名称/Name: 定时器Timer
 型号/Model: OPT



产品名称 Product Name:2P025
 线圈孔径高度 Coil Dia. & Height:Φ9×29.5
 电压 Voltage:AC12V~220V DC12V~24V
 线圈防护等级 Coil Protection:IP65



产品名称 Product Name:VX
 线圈孔径高度 Coil Dia. & Height:Φ11×35
 电压 Voltage:AC12V~220V DC12V~24V
 线圈防护等级 Coil Protection:IP65

VTM系列真空发生器 VTM Series Vacuum Ejector

型号 Model	供气口 Air Supply Port	真空口、排气口 Vacuum Port Exhaust Port	最大真空度 Max Vacuum Degree	最大真空流量 Max Vacuum Flow NL/Min	空气消耗 Air Consumption NL/Min	说明 Notes
VTM301	G1/4	G3/4	-94 Kpa	380	120-160	螺纹类型: -PT: PT螺纹 -NPT: NPT 螺纹 -G: G螺纹 Thread Type: -PT: PT Thread -NPT: NPT Thread -G: G Thread
VTM302	G1/4	G3/4	-94 Kpa	620	220-320	
VTM303	G1/4	G3/4	-94 Kpa	860	320-460	
VTM304	G1/4	G3/4	-94 Kpa	990	420-560	
VTM305	G1/4	G1	-94 Kpa	1380	560-805	
VTM306	G1/4	G1	-94 KPa	1460	660-940	

VIM系列真空发生器 VIM Series Vacuum Ejector

型号 Model	供气口 Air Supply Port	真空口、排气口 Vacuum Port Exhaust Port	最大真空度 Max Vacuum Degree	最大真空流量 Max Vacuum Flow NL/Min	空气消耗 Air Consumption NL/Min	说明 Notes
VIM301	G1/8	G1/2	-93 KPa	84	36-48	螺纹类型: -PT: PT螺纹 -NPT: NPT 螺纹 -G: G螺纹 Thread Type: -PT: PT Thread -NPT: NPT Thread -G: G Thread
VIM302	G1/8	G1/2	-93 KPa	152	70-92	
VIM303	G1/8	G1/2	-93 KPa	260	100-125	
VIM304	G1/8	G1/2	-93 KPa	290	145-175	

BX系列迷你型真空发生器 BX Series Mini Vacuum Ejector

型号 Model	供气口 Air Supply Port	真空口 Vacuum Port	最大真空度 Max Vacuum Degree	最大真空流量 Max Vacuum Flow NL/Min	空气消耗 Air Consumption NL/Min	说明 Notes
BX05	G1/8	G3/8	-92 KPa	32	21-24	螺纹类型: -PT: PT螺纹 -NPT: NPT 螺纹 -G: G螺纹 Thread Type: -PT: PT Thread -NPT: NPT Thread -G: G Thread
BX10	G1/8	G3/8	-92 KPa	62	43-48	
BX20	G1/8	G3/8	-92 KPa	124	86-96	
BX30	G1/8	G3/8	-92 KPa	185	129-144	

VBM系列迷你型真空发生器 VBM Series Mini Vacuum Ejector

型号 Model	供气口 Air Supply Port	真空口 Vacuum Port	最大真空度 Max Vacuum Degree	最大真空流量 Max Vacuum Flow NL/Min	空气消耗 Air Consumption NL/Min	说明 Notes
VBM201	G1/8	G3/8	-85 KPa	75	30	螺纹类型: -PT: PT螺纹 -NPT: NPT 螺纹 -G: G螺纹 Thread Type: -PT: PT Thread -NPT: NPT Thread -G: G Thread
VBM202	G1/8	G3/8	-85 KPa	150	60	
VBM203	G1/8	G3/8	-85 KPa	225	88	

VK系列真空发生器 VK Series Vacuum Ejector

型号 Model	喷嘴直径 Nozzle Diameter	真空口 Vacuum Port	最大真空度 Max Vacuum Degree	最大真空流量 Max Vacuum Flow NL/Min	空气消耗 Air Consumption NL/Min	说明 Notes
VK-05	0.5mm	—	—	6.5	11.5-15	螺纹类型: -PT: PT螺纹 -NPT: NPT 螺纹 -G: G螺纹 Thread Type: -PT: PT Thread -NPT: NPT Thread -G: G Thread
VK-07	0.7mm	—	—	16	21-28	
VK-10	1.0mm	—	—	40	34-46	
VK-12	1.2mm	—	—	50	47-70	

RF系列真空过滤器 RF Series Vacuum Filter

型号 Model	接管尺寸 Port Size	过滤精度 Filtration	使用压力 Operating Pressure	流量 Flow NL/Min	内部真空量 Inner Vacuum Capacity	说明 Notes
RF-10	G3/8	10um	-100~0 KPa	150	45 cm ²	螺纹类型: -PT: PT螺纹 -NPT: NPT 螺纹 -G: G螺纹 Thread Type: -PT: PT Thread -NPT: NPT Thread -G: G Thread
RF-15	G1/2	10um	-100~0 KPa	900	195 cm ²	
RF-20	G3/4	10um	-100~0 KPa	900	205 cm ²	
RF-25	G1	10um	-100~0 KPa	2520	195 cm ²	

EV系列真空发生器 EV Series Vacuum Ejector

	型号 Model	接管尺寸 Port Size	喷嘴直径 Nozzle Dia.	最大吸入流量 Max. Suction Flow Rate L/min	空气消耗量 Air Consumption L/min	型式 Type	说明 Notes
	EV-05	G1/8	0.5mm	6	13	空白:标准型 CK:附可调式压力开关 C:附不可调式压力开关 Blank: Standard Type CK: Attached Adjustabel Pressure Switch C: Attached Non-Adjustabel Pressure Switch	螺纹类型: -PT: PT螺纹 -NPT: NPT 螺纹 -G: G螺纹 Thread Type: -PT: PT Thread -NPT: NPT Thread -G: G Thread
	EV-10	G1/8	1.0mm	27	44		
	EV-15	G1/4	1.5mm	63	100		
	EV-20	G1/4	2.0mm	110	180		
	EV-25	G3/8	2.5mm	160	265		
	EV-30	G1/2	3.0mm	225	385		

ZFC系列真空发生器 ZFC Series Vacuum Ejector

	型号 Model	适合管子外径 Outer Diameter Of Applicable Pipe	流量 Flux l/min	使用介质 Using Medium	过滤精度 Filtration Accuracy	使用温度 Operating Temperature	说明 Notes
	ZFC100-04B	Φ4	10	空气、氮气 Air, Nitrogen Gas	10 μm	0~60℃	螺纹类型: -PT: PT螺纹 -NPT: NPT 螺纹 -G: G螺纹 Thread Type: -PT: PT Thread -NPT: NPT Thread -G: G Thread
	ZFC100-06B	Φ6	20		10 μm	0~60℃	
	ZFC200-06B	Φ6	30		10 μm	0~60℃	
	ZFC200-08B	Φ8	50		10 μm	0~60℃	

ZH系列真空发生器 ZH Series Vacuum Ejector

	型号 Model	接管尺寸 Port Size	喷嘴直径 Nozzle Dia.	最大吸入流量 Max. Suction Flow Rate L/min	空气消耗量 Air Consumption L/min	型式 Type	阀型 Valve Type	说明 Notes
	ZH05BS-06-06	φ6	0.5mm	5	13	B-盒式 B-Box Type	S-最高真空度: +88Kpa S-Max. Vacuum: +88Kpa	螺纹类型: -PT: PT螺纹 -NPT: NPT 螺纹 -G: G螺纹 Thread Type: -PT: PT Thread -NPT: NPT Thread -G: G Thread
	ZH07BS-06-06	φ6	0.7mm	12	23			
	ZH10BS-06-06	φ6	1.0mm	24	46			
	ZH13BS-08-06	φ6, φ8	1.3mm	40	78			
	ZH05BL-06-06	φ6	0.5mm	8	13		L-最高真空度: 48Kpa L-Max. Vacuum: +48Kpa	Thread Type: -PT: PT Thread -NPT: NPT Thread -G: G Thread
	ZH07BL-06-06	φ6	0.7mm	20	23			
	ZH10BL-06-06	φ6	1.0mm	34	46			
ZH13BL-08-06	φ6, φ8	1.3mm	70	78				

ZH系列真空发生器 ZH Series Vacuum Ejector

	型号 Model	接管尺寸 Port Size	喷嘴直径 Nozzle Dia.	最大吸入流量 Max. Suction Flow Rate L/min	空气消耗量 Air Consumption L/min	型式 Type	阀型 Valve Type	说明 Notes	
	ZH05BS-01-01	G1/8	0.5mm	5	13	B-盒式 B-Box Type	S-最高真空度: +88Kpa S-Max. Vacuum: +88Kpa	螺纹类型: -PT: PT螺纹 -NPT: NPT 螺纹 -G: G螺纹 Thread Type: -PT: PT Thread -NPT: NPT Thread -G: G Thread	
	ZH07BS-01-01	G1/8	0.7mm	12	23				
	ZH10BS-01-01	G1/8	1.0mm	24	46				
	ZH13BS-02-01	G1/4, G1/8	1.3mm	40	78		L-最高真空度: 48Kpa L-Max. Vacuum: +48Kpa		Thread Type: -PT: PT Thread -NPT: NPT Thread -G: G Thread
	ZH05BL-01-01	G1/8	0.5mm	8	13				
	ZH07BL-01-01	G1/8	0.7mm	20	23				
	ZH10BL-01-01	G1/8	1.0mm	34	46		D-直接接管式 D. Directly Piping Type		Thread Type: -PT: PT Thread -NPT: NPT Thread -G: G Thread
	ZH13BL-02-02	G1/4	1.3mm	70	78				

ZH系列真空发生器 ZH Series Vacuum Ejector

	型号 Model	接管尺寸 Port Size	喷嘴直径 Nozzle Dia.	最大吸入流量 Max. Suction Flow Rate L/min	空气消耗量 Air Consumption L/min	型式 Type	阀型 Valve Type	说明 Notes	
	ZH05DS-06-06-06	φ6	0.5mm	5	13	D-直接接管式 D. Directly Piping Type	S-最高真空度: +88Kpa S-Max. Vacuum: +88Kpa	螺纹类型: -PT: PT螺纹 -NPT: NPT 螺纹 -G: G螺纹 Thread Type: -PT: PT Thread -NPT: NPT Thread -G: G Thread	
	ZH07DS-06-06-06	φ6	0.7mm	12	23				
	ZH10DS-06-06-06	φ6	1.0mm	24	46				
	ZH13DS-08-06-06	φ6, φ8	1.3mm	40	78				
	ZH15DS-08-10-10	φ8, φ10	1.5mm	55	95				
	ZH18DS-10-12-12	φ10, φ12	1.8mm	65	150		L-最高真空度: 48Kpa L-Max. Vacuum: +48Kpa		
	ZH20DS-12-16-16	φ12, φ16	2.0mm	85	185				
	ZH05DL-06-06-06	φ6	0.5mm	8	13				
	ZH07DL-06-06-06	φ6	0.7mm	20	23				
	ZH10DL-06-06-06	φ6	1.0mm	34	46				
	ZH13DL-08-06-06	φ6, φ8	1.3mm	70	78		D-直接接管式 D. Directly Piping Type		Thread Type: -PT: PT Thread -NPT: NPT Thread -G: G Thread
	ZH15DL-08-10-10	φ8, φ10	1.5mm	75	95				
	ZH18DL-10-12-12	φ10, φ12	1.8mm	110	150				
	ZH20DL-12-16-16	φ12, φ16	2.0mm	135	185				

ZH系列真空发生器 ZH Series Vacuum Ejector



型号 Model	接管尺寸 Port Size	喷嘴直径 Nozzle Dia	最大吸入流量 Max. Suction Flow Rate L/min	空气消耗量 Air Consumption L/min	型式 Type	阀型 Valve Type	说明 Notes
ZH05DS-01-01-01	G1/8	0.5mm	5	13	D.直接接管式 D: Directly Piping Type	S-最高真空度: +88Kpa S-Max. Vacuum: +88Kpa	螺纹类型: -PT: PT螺纹 -NPT: NPT 螺纹 -G: G螺纹 Thread Type: -PT: PT Thread -NPT: NPT Thread -G: G Thread
ZH07DS-01-01-01	G1/8	0.7mm	12	23			
ZH10DS-01-01-01	G1/8	1.0mm	24	46			
ZH13DS-01-02-02	G1/4,G1/8	1.3mm	40	78			
ZH15DS-02-03-03	G3/8,G1/4	1.5mm	55	95			
ZH18DS-03-03-03	G3/8	1.8mm	65	150			
ZH20DS-03-04-04	G1/2,G3/8	2.0mm	85	185			
ZH05DL-01-01-01	G1/8	0.5mm	8	13		L-最高真空度: 48Kpa L-Max. Vacuum: +48Kpa	
ZH07DL-01-01-01	G1/8	0.7mm	20	23			
ZH10DL-01-01-01	G1/8	1.0mm	34	46			
ZH13DL-01-02-02	G1/4,G1/8	1.3mm	70	78			
ZH15DL-02-03-03	G3/8,G1/4	1.5mm	75	95			
ZH18DL-03-03-03	G3/8	1.8mm	110	150			
ZH20DL-03-04-04	G1/2,G3/8	2.0mm	135	185			

ZU系列真空发生器 ZU Series Vacuum Ejector



型号 Model	接管尺寸 Port Size	喷嘴直径 Nozzle Dia	最大吸入流量 Max. Suction Flow Rate L/min	空气消耗量 Air Consumption L/min	型式 Type	阀型 Valve Type	说明 Notes
ZU05S	φ6	0.5mm	7	9.5	管式 Tube Type	S-最高真空度: +88Kpa S-Max. Vacuum: +88Kpa	螺纹类型: -PT: PT螺纹 -NPT: NPT 螺纹 -G: G螺纹 Thread Type: -PT: PT Thread -NPT: NPT Thread -G: G Thread
ZU07S	φ6	0.7mm	12	19			
ZU05L	φ6	0.5mm	12	9.5		L-最高真空度: 48Kpa L-Max. Vacuum: +48Kpa	
ZU07L	φ6	0.7mm	21	19			

ZP系列真空吸盘 ZP Series Vacuum Pad



型号 Model	吸盘直径 Pad Dia.	吸盘类型 Pad Type	材料 Material	锁圈 Lock Ring
ZP02	02mm	U: 平形 C: 平形带肋 D: 深形 B: 风琴形	N: 丁腈橡胶 S: 硅橡胶 U: 聚氨酯橡胶 F: 氟化橡胶	无: 不带锁圈 -X19*: 不带锁圈
ZP04	04mm			
ZP06	06mm			
ZP08	08mm			
ZP10	10mm	U: Flat C: Flat With Ribs D: Deep B: Bellows	N: NBR S: Silicon Rubber U: Urethane Rubber F: Fluoro Rubber	Nil: Lock Ring -X19*: Without Lock Ring
ZP13	13mm			
ZP16	16mm			
ZP20	20mm			
ZP25	25mm			
ZP32	32mm			

ZPT系列垂直真空口带缓冲型吸盘 ZPT Series Vertical Vacuum Entry With Buffer Vacuum Pad



型号 Model	吸盘直径 Pad Dia.	吸盘类型 Pad Type	材料 Material	缓冲类型 Buffer Type	缓冲行程 Buffer Stroke	真空口连接 Vacuum Entry Port
ZPT02	02mm	U: 平形 C: 平形带肋 D: 深形 B: 风琴形	N: 丁腈橡胶 S: 硅橡胶 U: 聚氨酯橡胶 F: 氟化橡胶	J: 可回转型 K: 不可回转型	1: 2mm-8mm 2: 20mm-32mm 3: 40mm 4: 50mm	1: 外螺纹 (M3, M5, PT01) 2: 倒钩接头 (φ4mm, φ6mm) 3: 快速接头 (φ4mm, φ6mm, φ8mm)
ZPT04	04mm					
ZPT06	06mm					
ZPT08	08mm					
ZPT10	10mm	U: Flat C: Flat With Ribs D: Deep B: Bellows	N: NBR S: Silicon Rubber U: Urethane Rubber F: Fluoro Rubber	J: Rotating K: Non-Rotating	1: 2mm-8mm 2: 20mm-32mm 3: 40mm 4: 50mm	1: Male Thread (M3, M5, PT01) 2: Barb Fitting (φ4mm, φ6mm) 3: One-Touch Fitting (φ4mm, φ6mm, φ8mm)
ZPT13	13mm					
ZPT16	16mm					
ZPT20	20mm					
ZPT25	25mm					
ZPT32	32mm					

ZPR系列水平真空口带缓冲型吸盘 ZPR Series Lateral Vacuum Entry With Buffer Vacuum Pad



型号 Model	吸盘直径 Pad Dia.	吸盘类型 Pad Type	材料 Material	缓冲类型 Buffer Type	缓冲行程 Buffer Stroke	真空口连接 Vacuum Entry Port
ZPR02	02mm	U: 平形 C: 平形带肋 D: 深形 B: 风琴形	N: 丁腈橡胶 S: 硅橡胶 U: 聚氨酯橡胶 F: 氟化橡胶	J: 可回转型 K: 不可回转型	1: 2mm-8mm 2: 20mm-32mm 3: 40mm 4: 50mm	快速接头 (φ4mm, φ6mm, φ8mm)
ZPR04	04mm					
ZPR06	06mm					
ZPR08	08mm					
ZPR10	10mm	U: Flat C: Flat With Ribs D: Deep B: Bellows	N: NBR S: Silicon Rubber U: Urethane Rubber F: Fluoro Rubber	J: Rotating K: Non-Rotating	1: 2mm-8mm 2: 20mm-32mm 3: 40mm 4: 50mm	One-Touch Fitting (φ4mm, φ6mm, φ8mm)
ZPR13	13mm					
ZPR16	16mm					
ZPR20	20mm					
ZPR25	25mm					
ZPR32	32mm					

DSBC系列标准气缸 DSBC Series Standard Cylinder

Operating Pressure: 使用压力:0~0.8Mpa	型号 Model	缸径 Bore	接管尺寸 Port Size	活塞杆螺纹尺寸 Piston Port Size	可选用附件 Available Accessories	派生型号 Derivative Model	说明 Notes
	DSBC32	32	G1/8	M10 × 1.25	FNC-前法兰 SNCL-单显耳 SNCB-双显耳 LNG-斜单耳 HNC-双脚架 ZNC-前端盖中摆 ZNCM-中间摆轴 LZNG-中间耳轴座	DSBC:标准复动型 DSBC-S2:双轴复动型 DSBC-S3:双轴复动行程可调型 DSBC-A:带磁性 DSBC-空白:-5℃~80℃ DSBC-S6:-5℃~150℃	螺纹类型: -PT: PT螺纹 -NPT: NPT 螺纹 -G: G螺纹
	DSBC40	40	G1/4	M12 × 1.25			
	DSBC50	50	G1/4	M16 × 1.5			
	DSBC63	63	G3/8	M16 × 1.5			
	DSBC80	80	G3/8	M20 × 1.5			
	DSBC100	100	G1/2	M20 × 1.5			
	DSBC125	125	G1/2	M27 × 2			

DSBG系列标准气缸 DSBG series Standard Cylinder

Operating Pressure: 使用压力:0~0.8Mpa	型号 Model	缸径 Bore	接管尺寸 Port Size	活塞杆螺纹尺寸 Piston Port Size	可选用附件 Available Accessories	派生型号 Derivative Model	说明 Notes
	DSBG32	32	G1/8	M10 × 1.25	FNC-前法兰 SNCL-单显耳 SNCB-双显耳 LNG-斜单耳 HNC-双脚架 ZNC-前端盖中摆 ZNCM-中间摆轴 LZNG-中间耳轴座	DSBG:标准复动型 DSBG-S2:双轴复动型 DSBG-S3:双轴复动行程可调型 DSBG-A:带磁性 DSBG-空白:-5℃~80℃ DSBG-S6:-5℃~150℃	螺纹类型: -PT: PT螺纹 -NPT: NPT 螺纹 -G: G螺纹
	DSBG40	40	G1/4	M12 × 1.25			
	DSBG50	50	G1/4	M16 × 1.5			
	DSBG63	63	G3/8	M16 × 1.5			
	DSBG80	80	G3/8	M20 × 1.5			
	DSBG100	100	G1/2	M20 × 1.5			
	DSBG125	125	G1/2	M27 × 2			

DNC系列标准气缸 DNC Series Standard Cylinder

Operating Pressure: 使用压力:0~0.8Mpa	型号 Model	缸径 Bore	接管尺寸 Port Size	活塞杆螺纹尺寸 Piston Port Size	可选用附件 Available Accessories	派生型号 Derivative Model	说明 Notes
	DNC32	32	G1/8	M10 × 1.25	FNC-前法兰 SNCL-单显耳 SNCB-双显耳 LNG-斜单耳 HNC-双脚架 ZNC-前端盖中摆 ZNCM-中间摆轴 LZNG-中间耳轴座	DNC:标准复动型 DNC-S2:双轴复动型 DNC-S3:双轴复动行程可调型 DNC-A:带磁性 DNC-空白:-5℃~80℃ DNC-S6:-5℃~150℃	螺纹类型: -PT: PT螺纹 -NPT: NPT 螺纹 -G: G螺纹
	DNC40	40	G1/4	M12 × 1.25			
	DNC50	50	G1/4	M16 × 1.5			
	DNC63	63	G3/8	M16 × 1.5			
	DNC80	80	G3/8	M20 × 1.5			
	DNC100	100	G1/2	M20 × 1.5			
	DNC125	125	G1/2	M27 × 2			

DNG系列标准气缸 DNG Series Standard Cylinder

Operating Pressure: 使用压力:0~0.8Mpa	型号 Model	缸径 Bore	接管尺寸 Port Size	活塞杆螺纹尺寸 Piston Port Size	可选用附件 Available Accessories	派生型号 Derivative Model	说明 Notes
	DNG160	160	G3/4	M36 × 2	FNC-前法兰 SNCL-单显耳 SNCB-双显耳 LNG-斜单耳 HNC-双脚架 ZNC-前端盖中摆 ZNCM-中间摆轴 LZNG-中间耳轴座	DNG:标准复动型 DNG-S2:双轴复动型 DNG-S3:双轴复动行程可调型 DNG-A:带磁性 DNG-S6:-5℃~120℃	螺纹类型: -PT: PT螺纹 -NPT: NPT 螺纹 -G: G螺纹
	DNG200	200	G3/4	M36 × 2			
	DNG250	250	G1	M42 × 2			
	DNG320	320	G1	M48 × 2			

C95/C96系列圆管拉杆式标准气缸 C95/C96 Series Standard Cylinder

Operating Pressure: 使用压力:0~0.8Mpa	型号 Model	型号 Model	缸径 Bore	接管尺寸 Port Size	活塞杆螺纹尺寸 Piston Port Size	可选用附件 Available Accessories	派生型号 Derivative Model	说明 Notes
	C95 32	C96 32	32	PT1/8	M10 × 1.25	B-基本型 C-单显耳 D-双显耳 F-前法兰 G-无杆侧法兰 L-双脚架	C95/C96-D:带磁性 C95/C96:单轴复动型 C95/C96-W:双轴复动型	螺纹类型: -PT: PT螺纹 -NPT: NPT 螺纹 -G: G螺纹
	C95 40	C96 40	40	PT1/4	M12 × 1.25			
	C95 50	C96 50	50	PT1/4	M16 × 1.5			
	C95 63	C96 63	63	PT3/8	M16 × 1.5			
	C95 80	C96 80	80	PT3/8	M20 × 1.5			
	C95 100	C96 100	100	PT1/2	M20 × 1.5			

CA2系列标准气缸 CA2 Series Standard Cylinder

Operating Pressure: 使用压力:0~0.8Mpa	型号	缸径	接管尺寸	活塞杆螺纹尺寸	可选用附件	派生型号	说明
	Model	Bore	Port Size	Piston Port Size	Available Accessories	Derivative Model	Notes
	CA2 40	40	PT1/4	M14 × 1.5	B-基本型 C-单悬耳 D-双悬耳 F-前法兰 L-双脚架 T-中央耳轴 G-无杆侧法兰 B-Standard C-Single Clevis D-Double Clevis F-Front Flange L-Foot Bracket T-Center Trunnion G-Rodless Side Flange	CA2-D:带磁性 CA2-空:单轴复动型 CA2-W:双轴复动型 CA2-XC8:行程可调型 CA2-J:尼龙帆布型 CA2-K:耐热帆布型	螺纹类型: -PT: PT螺纹 -NPT: NPT 螺纹 -G: G螺纹 Thread Type: -PT: PT Thread -NPT: NPT Thread -G: G Thread
	CA2 50	50	PT3/8	M18 × 1.5			
	CA2 63	63	PT3/8	M18 × 1.5			
	CA2 80	80	PT1/2	M22 × 1.5			
	CA2 100	100	PT1/2	M26 × 1.5			

CS1/CS2系列标准气缸 CS1/CS2 Series Standard Cylinder

Operating Pressure: 使用压力:0~0.8Mpa	型号	型号	缸径	接管尺寸	活塞杆螺纹尺寸	可选用附件	派生型号	说明
	Model	Model	Bore	Port Size	Piston Port Size	Available Accessories	Derivative Model	Notes
	CS1 125	CS2 125	125	PT1/2	M30 × 1.5	B-基本型 C-单悬耳 D-双悬耳 F-前法兰 L-双脚架 T-中央耳轴 G-无杆侧法兰 B-Standard C-Single Clevis D-Double Clevis F-Front Flange L-Foot Bracket T-Center Trunnion G-Rodless Side Flange	CS1/CS2-D:带磁性 CS1/CS2:单轴复动型 CS1/CS2-W:双轴复动型 CS1/CS2-XC8:单轴复动行程可调型 CS1/CS2-J:尼龙帆布型 CS1/CS2-K:耐热帆布型	螺纹类型: -PT: PT螺纹 -NPT: NPT 螺纹 -G: G螺纹 Thread Type: -PT: PT Thread -NPT: NPT Thread -G: G Thread
	CS1 140	CS2 140	140	PT1/2	M30 × 1.5			
	CS1 160	CS2 160	160	PT3/4	M36 × 1.5			
	CS1 180	CS2 180	180	PT3/4	M40 × 1.5			
	CS1 200	CS2 200	200	PT3/4	M45 × 1.5			
	CS1 250	CS2 250	250	PT1	M56 × 2			
	CS1 300	CS2 300	300	PT1	M64 × 2			

CP95/CP96系列拉杆内藏式标准气缸 CP95/CP96 Series Standard Cylinder

Operating Pressure: 使用压力:0~0.8Mpa	型号	型号	缸径	接管尺寸	活塞杆螺纹尺寸	可选用附件	派生型号	说明
	Model	Model	Bore	Port Size	Piston Port Size	Available Accessories	Derivative Model	Notes
	CP95 32	CP96 32	32	PT1/8	M10 × 1.25	B-基本型 C-单悬耳 D-双悬耳 F-前法兰 L-双脚架 B-Standard C-Single Clevis D-Double Clevis F-Front Flange G-Rodless Side Flange L-Foot Bracket	CP95/CP96-D:带磁性 CP95/CP96:单轴复动型 CP95/CP96-W:双轴复动型	螺纹类型: -PT: PT螺纹 -NPT: NPT 螺纹 -G: G螺纹 Thread Type: -PT: PT Thread -NPT: NPT Thread -G: G Thread
	CP95 40	CP96 40	40	PT1/4	M14 × 1.5			
	CP95 50	CP96 50	50	PT1/4	M18 × 1.5			
	CP95 63	CP96 63	63	PT3/8	M18 × 1.5			
	CP95 80	CP96 80	80	PT3/8	M22 × 1.5			
	CP95 100	CP96 100	100	PT1/2	M25 × 1.5			

MB系列拉杆式标准气缸 MB Series Standard Cylinder

Operating Pressure: 使用压力:0~0.8Mpa	型号	缸径	接管尺寸	活塞杆螺纹尺寸	可选用附件	派生型号	说明
	Model	Bore	Port Size	Piston Port Size	Available Accessories	Derivative Model	Notes
	MBB32	32	PT1/8	M10 × 1.25	B-基本型 C-单悬耳 D-双悬耳 F-前法兰 L-双脚架 B-Standard C-Single Clevis D-Double Clevis F-Front Flange G-Rodless Side Flange L-Foot Bracket	MB-D:带磁性 MB-空:单轴复动型 MB-W:双轴复动型	螺纹类型: -PT: PT螺纹 -NPT: NPT 螺纹 -G: G螺纹 Thread Type: -PT: PT Thread -NPT: NPT Thread -G: G Thread
	MBB40	40	PT1/4	M14 × 1.5			
	MBB50	50	PT1/4	M18 × 1.5			
	MBB63	63	PT3/8	M18 × 1.5			
	MBB80	80	PT3/8	M22 × 1.5			
	MBB100	100	PT1/2	M26 × 1.5			
	MBB125	125	PT1/2	M27 × 2			

SMB系列不锈钢标准气缸 SMB Series Stainless Steel Standard Cylinder

Operating Pressure: 使用压力:0~0.8Mpa	型号	缸径	接管尺寸	活塞杆螺纹尺寸	可选用附件	派生型号	说明
	Model	Bore	Port Size	Piston Port Size	Available Accessories	Derivative Model	Notes
	SMB32	32	PT1/8	M10 × 1.25	B-基本型 C-单悬耳 D-双悬耳 F-前法兰 L-双脚架 B-Standard C-Single Clevis D-Double Clevis F-Front Flange G-Rodless Side Flange L-Foot Bracket	SMB-D:带磁性 SMB-空:单轴复动型 SMB-W:双轴复动型	螺纹类型: -PT: PT螺纹 -NPT: NPT 螺纹 -G: G螺纹 Thread Type: -PT: PT Thread -NPT: NPT Thread -G: G Thread
	SMB40	40	PT1/4	M14 × 1.5			
	SMB50	50	PT1/4	M18 × 1.5			
	SMB63	63	PT3/8	M18 × 1.5			
	SMB80	80	PT3/8	M22 × 1.5			
	SMB100	100	PT1/2	M26 × 1.5			
	SMB125	125	PT1/2	M27 × 2			

MB1系列拉杆内藏式标准气缸 MB1 Series Standard Cylinder

Operating Pressure: 使用压力:0~0.8Mpa	型号 Model	缸径 Bore	接管尺寸 Port Size	活塞杆螺纹尺寸 Piston Port Size	可选用附件 Available Accessories	派生型号 Derivative Model	说明 Notes
	MB1B32	32	PT1/8	M10×1.25	B-基本型 C-单悬耳 D-双悬耳 F-前法兰 G-无杆侧法兰 L-双脚架 B-Standard C-Single Clevis D-Double Clevis F-Front Flange G-Rodless Side Flange L-Foot Bracket	MB1-D:带磁性 MB1-空白:单轴复动型 MB1-W:双轴复动型 MB1-D:With Magnet MB1-Blank:Single Rod Double Acting MB1-W:Double Rods Double Acting	螺纹类型: -PT: PT螺纹 -NPT: NPT 螺纹 -G: G螺纹 Thread Type: -PT: PT Thread -NPT: NPT Thread -G: G Thread
	MB1B40	40	PT1/4	M14×1.5			
	MB1B50	50	PT1/4	M18×1.5			
	MB1B63	63	PT3/8	M18×1.5			
	MB1B80	80	PT3/8	M22×1.5			
	MB1B100	100	PT1/2	M26×1.5			
	MB1B125	125	PT1/2	M27×2			

SE系列标准气缸 SE Series Standard Cylinder

Operating Pressure: 使用压力:0~0.8Mpa	型号 Model	缸径 Bore	接管尺寸 Port Size	活塞杆螺纹尺寸 Piston Port Size	可选用附件 Available Accessories	派生型号 Derivative Model	说明 Notes
	SE32	32	PT1/8	M10×1.25	FA-前法兰 FB-后法兰 CA-单悬耳 CB-双悬耳 LB-双脚架 Y-Y接头 I-接头 TC-中间摆轴 FA-Front Flange FB-Rear Flange CA-Single Clevis CB-Double Clevis LB-Foot Bracket Y-Y Joint I-Joint TC-Centertrunnion	SE-单轴复动型 SE-S:带磁性 SED:双轴复动型 SEJ:双轴复动可调型 SE: Single Rod Double Acting SE-S:With Magnet SED:Double Rods Double Acting SEJ:Double Rods Double Acting Adjustable	螺纹类型: -PT: PT螺纹 -NPT: NPT 螺纹 -G: G螺纹 Thread Type: -PT: PT Thread -NPT: NPT Thread -G: G Thread
	SE40	40	PT1/4	M12×1.25			
	SE50	50	PT1/4	M16×1.5			
	SE63	63	PT3/8	M16×1.5			
	SE80	80	PT3/8	M20×1.5			
	SE100	100	PT1/2	M20×1.5			
	SE125	125	PT1/2	M27×2			

SI系列标准气缸 SI Series Standard Cylinder

Operating Pressure: 使用压力:0~0.8Mpa	型号 Model	缸径 Bore	接管尺寸 Port Size	活塞杆螺纹尺寸 Piston Port Size	可选用附件 Available Accessories	派生型号 Derivative Model	说明 Notes
	SI32	32	PT1/8	M10×1.25	FA-前法兰 FB-后法兰 CA-单悬耳 CB-双悬耳 CR-斜单耳 LB-双脚架 TC-中间摆轴 FTC-前端盖中摆 FA-Front Flange FB-Rear Flange CA-Single Clevis CB-Double Clevis CR-Oblique Single Ear LB-Foot Bracket TC-Center Trunnion FTC-Frontend Cap/Pendulum	SI:单轴复动型 SI-S:带磁性 SID:双轴复动可调型 SAI:前弹簧(预伸)型 STI:后弹簧(预伸)型 SI-B:304不锈钢活塞杆型 SI-F:带电磁阀型 SI-LF:前端带锁型 SI-LB:后端带锁型 SI: Single Rod Double Acting SI-S:With Magnet SID:Double Rods Double Acting SAI:Front Spring STI:Rear Spring SI-B:304 Stainless steel Piston SI-F:With Solenoid Valve SI-LF:Front End Lock Type SI-LB:Rear End Lock Type	螺纹类型: -PT: PT螺纹 -NPT: NPT 螺纹 -G: G螺纹 Thread Type: -PT: PT Thread -NPT: NPT Thread -G: G Thread
	SI40	40	PT1/4	M12×1.25			
	SI50	50	PT1/4	M16×1.5			
	SI63	63	PT3/8	M16×1.5			
	SI80	80	PT3/8	M20×1.5			
	SI100	100	PT1/2	M20×1.5			
	SI125	125	PT1/2	M27×2			
	SI160	160	PT3/4	M36×2			
	SI200	200	PT3/4	M36×2			

JSI系列标准气缸 JSI Series Standard Cylinder

Operating Pressure: 使用压力:0~0.8Mpa	型号 Model	缸径 Bore	接管尺寸 Port Size	活塞杆螺纹尺寸 Piston Port Size	可选用附件 Available Accessories	派生型号 Derivative Model	说明 Notes
	JSI32	32	PT1/8	M10×1.25	FA-前法兰 FB-后法兰 CA-单悬耳 CB-双悬耳 CR-斜单耳 LB-双脚架 TC-中间摆轴 FA-Front Flange FB-Rear Flange CA-Single Clevis CB-Double Clevis CR-Oblique Single Ear LB-Foot Bracket TC-Center Trunnion	JSI:标准复动型 JSID:双轴复动型 JSIJ:双轴复动行程可调型 JSI: Single Rod Double Acting JSID:Double Rods Double Acting JSIJ:Double Rods Double Acting Adjustable	螺纹类型: -PT: PT螺纹 -NPT: NPT 螺纹 -G: G螺纹 Thread Type: -PT: PT Thread -NPT: NPT Thread -G: G Thread
	JSI40	40	PT1/4	M14×1.5			
	JSI50	50	PT1/4	M18×1.5			
	JSI63	63	PT3/8	M18×1.5			
	JSI80	80	PT3/8	M22×1.5			
	JSI100	100	PT1/2	M26×1.5			
	JSI125	125	PT1/2	M27×2			

SSI系列不锈钢标准气缸 SSI Series Stainless Steel Standard Cylinder

Operating Pressure: 使用压力:0~0.8Mpa	型号 Model	缸径 Bore	接管尺寸 Port Size	活塞杆螺纹尺寸 Piston Port Size	可选用附件 Available Accessories	派生型号 Derivative Model	说明 Notes
	SSI32	32	PT1/8	M10×1.25	FA-前法兰 FB-后法兰 CA-单悬耳 CB-双悬耳 CR-斜单耳 LB-双脚架 TC-中间摆轴 FTC-前端盖中摆 FA-Front Flange FB-Rear Flange CA-Single Clevis CB-Double Clevis CR-Oblique Single Ear LB-Foot Bracket TC-Center Trunnion FTC-Frontend Cap/Pendulum	SSI:单轴复动型 SSI-S:带磁性 SSID:双轴复动型 SSIJ:双轴复动行程可调型 SSAI:前弹簧(预伸)型 SSTI:后弹簧(预伸)型 SSI-B:304不锈钢活塞杆型 SSI-F:带电磁阀型 SSI-LF:前端带锁型 SSI-LB:后端带锁型 SSI: Single Rod Double Acting SSI-S:With Magnet SSID:Double Rods Double Acting SSIJ:Double Rods Double Acting Adjustable SSAI:Front Spring SSTI:Rear Spring SSI-B:304 Stainless steel Piston SSI-F:With Solenoid Valve SSI-LF:Front End Lock Type SSI-LB:Rear End Lock Type	螺纹类型: -PT: PT螺纹 -NPT: NPT 螺纹 -G: G螺纹 Thread Type: -PT: PT Thread -NPT: NPT Thread -G: G Thread
	SSI40	40	PT1/4	M12×1.25			
	SSI50	50	PT1/4	M16×1.5			
	SSI63	63	PT3/8	M16×1.5			
	SSI80	80	PT3/8	M20×1.5			
	SSI100	100	PT1/2	M20×1.5			
	SSI125	125	PT1/2	M27×2			
	SSI160	160	PT3/4	M36×2			
	SSI200	200	PT3/4	M36×2			

SC系列标准气缸 SC Series Standard Cylinder

Operating Pressure: 使用压力:0~0.8Mpa	型号 Model	缸径 Bore	接管尺寸 Port Size	活塞杆螺纹尺寸 Piston Port Size	可选用附件 Available Accessories	派生型号 Derivative Model	说明 Notes	
	SC32	32	PT1/8	M10 × 1.25	FA-前法兰 FB-后法兰 CA-单悬耳 CB-双悬耳 LB-双脚架 Y-Y接头 TC-中间摆轴 I-接头 FA-Front Flange FB-Rear Flange CA-Single Clevis CB-Double Clevis LB-Foot Bracket Y-Y Joint I-I Joint TC-Center Trunnion	SC-S:单轴复动型 SC-S:带磁性 SCD:双轴复动型 SCJ:双轴复动可调型 SAC:前弹簧(预伸型) STC:后弹簧(预伸型) SC-B:304不锈钢活塞杆型 SC-F:带电磁阀型 SC-T:多位复动型 SC-LF:前端带锁型 SC-LB:后端带锁型 BSC:拖架型	SC:Single Rod Double Acting SC-S:With Magnet SCD:Double Rods Double Acting SCJ:Double Rods Double Acting Adjustable SAC:Front Spring STC:Rear Spring SC-B:304 Stainless steel Piston SC-F:With Solenoid Valve SC-T:Multi-position Type SC-LF:Front End Lock Type SC-LB:Rear End Lock Type BSC:Enclasp Type	螺纹类型: -PT: PT 螺纹 -NPT: NPT 螺纹 -G: G 螺纹
	SC40	40	PT1/4	M12 × 1.25				
	SC50	50	PT1/4	M16 × 1.5				
	SC63	63	PT3/8	M16 × 1.5				
	SC80	80	PT3/8	M20 × 1.5				
	SC100	100	PT1/2	M20 × 1.5				
	SC125	125	PT1/2	M27 × 2				
	SC160	160	PT1/2	M36 × 2				
	SC200	200	PT3/4	M36 × 2				
	SC250	250	PT3/4	M42 × 2				
SC320	320	PT3/4	M48 × 2					

SSC系列不锈钢标准气缸 SSC Series Stainless Steel Standard Cylinder

Operating Pressure: 使用压力:0~0.8Mpa	型号 Model	缸径 Bore	接管尺寸 Port Size	活塞杆螺纹尺寸 Piston Port Size	可选用附件 Available Accessories	派生型号 Derivative Model	说明 Notes	
	SSC32	32	PT1/8	M10 × 1.25	FA-前法兰 FB-后法兰 CA-单悬耳 CB-双悬耳 LB-双脚架 Y-Y接头 TC-中间摆轴 I-接头 FA-With Flange FB-Rear Flange CA-Single Clevis CB-Double Clevis LB-Foot Bracket Y-Y Joint I-I Joint TC-Center Trunnion	SSC-S:单轴复动型 SSC-S:带磁性 SSCD:双轴复动型 SSCJ:双轴复动可调型 SSAC:前弹簧(预伸型) SSTC:后弹簧(预伸型) SSC-B:304不锈钢活塞杆型 SSC-F:带电磁阀型 SSC-T:多位复动型 SSC-LF:前端带锁型 SSC-LB:后端带锁型 BSSC:拖架型	SSC:Single Rod Double Acting SSC-S:With Magnet SSCD:Double Rods Double Acting SSCJ:Double Rods Double Acting Adjustable SSAC:Front Spring SSTC:Rear Spring SSC-B:304 Stainless steel Piston SSC-F:With Solenoid Valve SSC-T:Multi-position Type SSC-LF:Front End Lock Type SSC-LB:Rear End Lock Type BSSC:Enclasp Type	螺纹类型: -PT: PT 螺纹 -NPT: NPT 螺纹 -G: G 螺纹
	SSC40	40	PT1/4	M12 × 1.25				
	SSC50	50	PT1/4	M16 × 1.5				
	SSC63	63	PT3/8	M16 × 1.5				
	SSC80	80	PT3/8	M20 × 1.5				
	SSC100	100	PT1/2	M20 × 1.5				
	SSC125	125	PT1/2	M27 × 2				
	SSC160	160	PT1/2	M36 × 2				
	SSC200	200	PT3/4	M36 × 2				
	SSC250	250	PT3/4	M42 × 2				
SSC320	320	PT3/4	M48 × 2					

SU系列标准气缸 SU Series Standard Cylinder

Operating Pressure: 使用压力:0~0.8Mpa	型号 Model	缸径 Bore	接管尺寸 Port Size	活塞杆螺纹尺寸 Piston Port Size	可选用附件 Available Accessories	派生型号 Derivative Model	说明 Notes	
	SU32	32	PT1/8	M10 × 1.25	FA-前法兰 FB-后法兰 CA-单悬耳 CB-双悬耳 LB-双脚架 Y-Y接头 I-接头 TC-中间摆轴 FA-Front Flange FB-Rear Flange CA-Single Clevis CB-Double Clevis LB-Foot Bracket Y-Y Joint I-I Joint TC-Centertrunnion	SU-S:带磁性 SUD:双轴型 SUJ:双轴可调型 SAU:前弹簧(预伸型) STU:后弹簧(预伸型) SU-B:304不锈钢活塞杆型 SU-F:带电磁阀型 SU-LF:前端带锁型 SU-LB:后端带锁型	SU:Single Rod Double Acting(Steel) SUD:Double Rod SUJ:Double Rod Adjustable SAU:Front Spring STU:Rear Spring SU-B:304 Stainless steel Piston SU-F:With Solenoid Valve SU-LF:Front End Lock Type SU-LB:Rear End Lock Type	螺纹类型: -PT: PT 螺纹 -NPT: NPT 螺纹 -G: G 螺纹
	SU40	40	PT1/4	M12 × 1.25				
	SU50	50	PT1/4	M16 × 1.5				
	SU63	63	PT3/8	M16 × 1.5				
	SU80	80	PT3/8	M20 × 1.5				
	SU100	100	PT1/2	M20 × 1.5				
	SU125	125	PT1/2	M27 × 2				
	SU160	160	PT1/2	M36 × 2				

SG/SGC系列标准气缸 SG/SGC Series Standard Cylinder

Operating Pressure: 使用压力:0~0.8Mpa	型号 Model	缸径 Bore	接管尺寸 Port Size	活塞杆螺纹尺寸 Piston Port Size	可选用附件 Available Accessories	派生型号 Derivative Model	说明 Notes	
	SG125	125	PT1/2	M27 × 2.0	FA-前法兰 FB-后法兰 CA-单悬耳 CB-双悬耳 CR-斜单耳 LB-双脚架 FTC-前端盖中摆 TC-中间摆轴 FA-Front Flange FB-Rear Flange CA-Single Clevis CB-Double Clevis CR-Oblique Single Ear LB-Foot Bracket TC-Center Trunnion FTC-Front End Cap Pendulum	SG:标准复动型(钢管型) SGD:双轴复动型(钢管型) SGJ:双轴复动行程可调型(钢管型) SGC:标准复动型(铝管型) SGCD:双轴复动行程可调型(铝管型) SGCJ:双轴复动行程可调型(铝管型) SG:Single Rod Double Acting(Steel) SGD:Double Rods Double Acting(Steel) SGJ:Double Rods Double Acting Adjustable(Steel) SGC:Single Rod Double Acting(Aluminum Barrel) SGCD:Double Rods Double Acting(Aluminum Barrel) SGCJ:Double Rods Double Acting Adjustable(Aluminum Barrel)	SG:Standard Double Acting(Steel) SGD:Double Rods Double Acting(Steel) SGJ:Double Rods Double Acting Adjustable(Steel) SGC:Single Rod Double Acting(Aluminum Barrel) SGCD:Double Rods Double Acting(Aluminum Barrel) SGCJ:Double Rods Double Acting Adjustable(Aluminum Barrel)	螺纹类型: -PT: PT 螺纹 -NPT: NPT 螺纹 -G: G 螺纹
	SG160	160	PT3/4	M36 × 2.0				
	SG200	200	PT3/4	M36 × 2.0				
	SG250	250	PT1	M42 × 2.0				

QGA、QGB系列标准气缸 QGA、QGB Series Standard Cylinder

Operating Pressure: 使用压力:0~0.8Mpa	型号 Model	型号 Model	缸径 Bore	接管尺寸 Port Size	活塞杆螺纹尺寸 Piston Port Size	可选用附件 Available Accessories	派生型号 Derivative Model	说明 Notes
		QGA63	QGB63	63	G1/4	M16×1.5	MF1-前法兰 MF2-后法兰 MF4-单悬耳 MF2-双悬耳 MS1-底座式 MT4-中间轴销式 MF1-Front Flange MF2-Rear Flange MP4-Single Clevis MP2-Double Clevis MS1-Base Type MT4-Center Trunnion Type	QG:不带磁性 QG-S:带磁性 QGA:无缓冲型 QGB:带缓冲型 QG:No Magnet QG-S:With Magnet QGA:No Cushioning QGB:With Cushioning
QGA80	QGB80	80	G1/4	M16×1.5				
QGA100	QGB100	100	G1/2	M20×1.5				
QGA125	QGB125	125	G1/2	M27×2				
QGA160	QGB160	160	G1/2	M33×2				
QGA200	QGB200	200	G1/2	M36×2				
QGA250	QGB250	250	G3/4	M42×2				
QGA320	QGB320	320	G3/4	M48×2				
QGA400	QGB400	400	G1	M56×4				

DSNU系列不锈钢迷你气缸 DSNU Series Stainless Steel Mini Cylinder

Operating Pressure: 使用压力:0~0.8Mpa	型号 Model	缸径 Bore	接管尺寸 Port Size	活塞杆螺纹尺寸 Piston Port Size	可选用附件 Available Accessories	派生型号 Derivative Model	说明 Notes
	DSNU8	8	M5	M4	FNB-法兰板 HBN-脚架 LBN-耳环座 Y-双肘Y接头 I-单肘接头 FNB-Flange HBN-Foot Bracket LBN-Earring Joint Y-Y Fitting I-Rod End Joint	DSNU:单轴双动型 DSNU-A:带磁性 DSNU-S2:双轴 DSNU-S3:双可调 ESNU:单轴单动(前置弹簧) ESNUZ:单轴单动(后置弹簧) DSNU:Single Rod Double Acting DSNU-A:With Magnet DSNU-S2:Double Rods DSNU-S3:Double Rods Adjustable ESNU:Single Rod Single Acting(Front Spring) ESNUZ:Single Rod Single Acting(Rear Spring)	螺纹类型: -PT: PT螺纹 -NPT: NPT 螺纹 -G: G螺纹 Thread Type: -PT: PT Thread -NPT: NPT Thread -G: G Thread
DSNU10	10	M5	M4				
DSNU12	12	M5	M6				
DSNU16	16	M5	M6				
DSNU20	20	M5	M8				
DSNU25	25	G1/8	M10×1.25				

CG1系列铝合金轻型气缸 CG1 Series Aluminum Alloy Light-Duty Cylinder

Operating Pressure: 使用压力:0~0.8Mpa	型号 Model	缸径 Bore	接管尺寸 Port Size	活塞杆螺纹尺寸 Piston Port Size	可选用附件 Available Accessories	派生型号 Derivative Model	说明 Notes
	CG1 20	20	G1/8	M8×1.25	B-基本型 D-双悬耳 W-双肘Y接头 G-无杆侧法兰 L-双脚架 C-单悬耳 F-前法兰 V-单肘接头 B-Standard C-Single Clevis D-Double Clevis F-Front Flange W-Double Knuckle Joint V-Rod End Joint G-Rodless Side Flange L-Foot Bracket	CDG1BN:带磁性 CG1K:活塞杆不回转型 CG1R:直接安装型 CG1-J:尼龙帆布型 CG1-K:耐热帆布型 CDM2B:With Magnet CG1K:Non-rotating Rod CG1:Direct Installation CG1-J:Nylon Tarpaulin CG1-K:Heat Resistant Tarpaulin	螺纹类型: -PT: PT螺纹 -NPT: NPT 螺纹 -G: G螺纹 Thread Type: -PT: PT Thread -NPT: NPT Thread -G: G Thread
CG1 25	25	G1/8	M10×1.25				
CG1 32	32	G1/8	M10×1.25				
CG1 40	40	G1/8	M14×1.5				
CG1 50	50	G1/4	M18×1.5				
CG1 63	63	G1/4	M18×1.5				
CG1 80	80	G3/8	M22×1.5				
CG1 100	100	G1/2	M26×1.5				

C85系列不锈钢迷你气缸 C85 Series Stainless Steel Mini Cylinder

Operating Pressure: 使用压力:0~0.8Mpa	型号 Model	缸径 Bore	接管尺寸 Port Size	活塞杆螺纹尺寸 Piston Port Size	可选用附件 Available Accessories	派生型号 Derivative Model	说明 Notes
	C85 08	8	M5	M4×0.7	B-基本型 L-双脚架 W-双肘Y接头 G-无杆侧法兰 B-Standard F-Front Flange L-Foot Bracket T-Front & Rear Trunnion W-Double Knuckle Joint V-Rod End Joint G-Rodless Side Flange	CD85:带磁性 C85W:双轴型 C85-S:前弹簧(预缩) C85-T:后弹簧(预伸) C85-J:尼龙帆布型 C85-K:耐热帆布型 CD85:With Magnet C85W:Double Rod C85-S:Front Spring C85-T:Rear Spring C85-J:Nylon Tarpaulin C85-K:Heat Resistant Tarpaulin	螺纹类型: -PT: PT螺纹 -NPT: NPT 螺纹 -G: G螺纹 Thread Type: -PT: PT Thread -NPT: NPT Thread -G: G Thread
C85 10	10	M5	M4×0.7				
C85 12	12	M5	M6×1				
C85 16	16	M5	M6×1				
C85 20	20	G1/8	M8×1.25				
C85 25	25	G1/8	M10×1.25				

CM2B系列不锈钢迷你气缸 CM2B Series Stainless Steel Mini Cylinder

Operating Pressure: 使用压力:0~0.8Mpa	型号 Model	缸径 Bore	接管尺寸 Port Size	活塞杆螺纹尺寸 Piston Port Size	可选用附件 Available Accessories	派生型号 Derivative Model	说明 Notes
	CM2B16	16	M5	M6×1	B-基本型 D-双悬耳 W-双肘Y接头 G-无杆侧法兰 L-双脚架 B-Standard C-Single Clevis D-Double Clevis F-Front Flange W-Double Knuckle Joint V-Rod End Joint G-Rodless Side Flange L-Foot Bracket	CDM2B:带磁性 CM2R:直接安装型 CM2B-S:前弹簧(预缩) CM2B-T:后弹簧(预伸) CM2B-J:尼龙帆布型 CM2B-K:耐热帆布型 CDM2B:With Magnet CM2R:Direct Installation CM2B-S:Front Spring CM2B-T:Rear Spring CM2B-J:Nylon Tarpaulin CM2B-K:Heat Resistant Tarpaulin	螺纹类型: -PT: PT螺纹 -NPT: NPT 螺纹 -G: G螺纹 Thread Type: -PT: PT Thread -NPT: NPT Thread -G: G Thread
CM2B20	20	G1/8	M8×1.25				
CM2B25	25	G1/8	M10×1.25				
CM2B32	32	G1/8	M10×1.25				
CM2B40	40	G1/4	M14×1.5				

CJ1系列微型气缸 CJ1 Series Mini Cylinder

Operating Pressure: 使用压力:0~0.8Mpa	型号 Model	缸径 Bore	接管尺寸 Port Size	活塞杆螺纹尺寸 Piston Port Size	派生型号 Derivative Model	说明 Notes	
		CJ1 4 × 5	4	气管(Tube):4mm × 2.5mm	M2 × 0.4	CJ1B:单轴复动型 CJ1BS:单动弹簧压回型 CJ1B:Single Rod Double Acting CJ1BS:Single Rod Spring Return	螺纹类型: -PT: PT螺纹 -NPT: NPT 螺纹 -G: G螺纹 Thread Type: -PT: PT Thread -NPT: NPT Thread -G: G Thread
		CJ1 4 × 10	4	气管(Tube):4mm × 2.5mm	M2 × 0.4		
		CJ1 4 × 15	4	气管(Tube):4mm × 2.5mm	M2 × 0.4		
		CJ1 4 × 20	4	气管(Tube):4mm × 2.5mm	M2 × 0.4		

CJ2B系列不锈钢迷你气缸 CJ2B Series Stainless Steel Mini Cylinder

Operating Pressure: 使用压力:0~0.8Mpa	型号 Model	缸径 Bore	接管尺寸 Port Size	活塞杆螺纹尺寸 Piston Port Size	可选用附件 Available Accessories	派生型号 Derivative Model	说明 Notes	
		CJ2B	6	M5	M3 × 0.5	B-基本型 C-单悬耳 D-双悬耳 F-前法兰 W-双肘Y接头 V-单肘接头 G-无杆侧法兰 L-双脚架	CDJ2B:带磁性 CJ2WB:双轴型 CJ2BK:活塞杆不同转型 CJ2R:直接安装型 CJ2Z:内置速度控制阀	螺纹类型: -PT: PT螺纹 -NPT: NPT 螺纹 -G: G螺纹
		CJ2B	10	M5	M4 × 0.7	B-Standard C-Single Clevis D-Double Clevis F-Front Flange W-Double Knuckle Joint V-Rod End Joint G-Rodless Side Flange L-Foot Bracket	CDJ2B: With Magnet CJ2WB: Double Rod CJ2BK: Non-rotating Rod CJ2R: Direct Installation CJ2Z: Built-in Speed Controller Type	Thread Type: -PT: PT Thread -NPT: NPT Thread -G: G Thread
		CJ2B	16	M5	M5 × 0.8			

CJPB系列螺纹气缸(单作用) CJPB Series Slim Cylinder(Single Acting)

Operating Pressure: 使用压力:0~0.8Mpa	型号 Model	缸径 Bore	接管尺寸 Port Size	活塞杆螺纹尺寸 Piston Port Size	可选用附件 Available Accessories	派生型号 Derivative Model	说明 Notes	
		CJPB6	6	M5	M3 × 0.5	—	CJP:单动弹簧压回型 CJP-B:面板安装型 CJP-S:埋入型 CJPD:带磁性	螺纹类型: -PT: PT螺纹 -NPT: NPT 螺纹 -G: G螺纹
		CJPB10	10	M5	M4 × 0.7			
		CJPB15	15	M5	M5 × 0.8			Thread Type: -PT: PT Thread -NPT: NPT Thread -G: G Thread

CJP2系列微型气缸(双作用) CJP2 Series Mini Cylinder (Double Acting)

Operating Pressure: 使用压力:0~0.8Mpa	型号 Model	缸径 Bore	接管尺寸 Port Size	活塞杆螺纹尺寸 Piston Port Size	可选用附件 Available Accessories	派生型号 Derivative Model	说明 Notes	
		CJP2 6	6	M5	M3 × 0.5	B-基本型 D-双悬耳 F-前法兰 L-双脚架 T-耳轴型	CJP2:单轴复动型 CDJP2:带磁性	螺纹类型: -PT: PT螺纹 -NPT: NPT 螺纹 -G: G螺纹
		CJP2 10	10	M5	M4 × 0.7			
		CJP2 15	15	M5	M5 × 0.8		B-Standard D-Double Clevis F-Front Flange L-Foot Bracket T-Trunnion Type	CJP2:Single Rod Double Acting CDJP2:With Magnet

PB/PBR系列笔形气缸 PB/PBR Series Pen Shape Cylinder

Operating Pressure: 使用压力:0~0.8Mpa	型号 Model	型号 Model	缸径 Bore	接管尺寸 Port Size	活塞杆螺纹尺寸 Piston Port Size	可选用附件 Available Accessories	派生型号 Derivative Model	说明 Notes	
		PB4	PBR4	4	M5 × 0.8	M2 × 0.4	FA-前法兰 LB-双脚架 CJ-脚架型 FA-Front Flange LB-Foot Bracket CJ-Foot Type	PB/PBR:复动型 PSB/PSBR:单动伸出型 PTB/PTBR:单动伸入型 PBD:双轴复动型 PBJ:双轴复动行程可调型 PB/PBR:Double Acting Spring Pull PSB/PSBR:Single Acting Spring Push PTB/PTBR:Single Acting Spring Push PBD:Double Rods Double Acting PBJ:Double Rods Double Acting Adjustable	螺纹类型: -PT: PT螺纹 -NPT: NPT 螺纹 -G: G螺纹 Thread Type: -PT: PT Thread -NPT: NPT Thread -G: G Thread
		PB6	PBR6	6	M5 × 0.8	M3 × 0.5			
		PB8	PBR8	8	M5 × 0.8	M4 × 0.7			
		PB10	PBR10	10	M5 × 0.8	M4 × 0.7			
		PB12	PBR12	12	M5 × 0.8	M5 × 0.8			
		PB16	PBR16	16	M5 × 0.8	M5 × 0.8			

MAL/MBL系列铝合金迷你气缸 MAL/MBL Series Aluminum Alloy Slim Cylinder

Operating Pressure: 使用压力:0~0.8Mpa	型号 Model	型号 Model	缸径 Bore	接管尺寸 Port Size	活塞杆螺纹尺寸 Piston Port Size	可选用附件 Available Accessories	派生型号 Derivative Model	说明 Notes	
		MAL16	MBL16	16	M5	M6 × 1	FA-前法兰 SDB-铰耳固定架 LB-双脚架 FA-Front Flange SDB-Hinge Ear Bracket LB-Foot Bracket	MAL:复动型 MSAL:单动伸出型 MTAL:单动引入型 MAJL:双轴复动型 MAL:双轴复动行程可调型 MSAL:Single Acting Spring Pull MTAL:Single Acting Spring Push MAL:Double Rods Double Acting MAJL:Double Rods Double Acting Adjustable	螺纹类型: -PT: PT螺纹 -NPT: NPT 螺纹 -G: G螺纹 Thread Type: -PT: PT Thread -NPT: NPT Thread -G: G Thread
		MAL20	MBL20	20	PT1/8	M8 × 1.25			
		MAL25	MBL25	25	PT1/8	M10 × 1.25			
		MAL32	MBL32	32	PT1/8	M10 × 1.25			
		MAL40	MBL40	40	PT1/4	M12 × 1.25			

SMAL系列不锈钢迷你气缸 SMAL Series Stainless Steel Slim Cylinder

Operating Pressure: 使用压力:0~0.8Mpa	型号 Model	缸径 Bore	接管尺寸 Port Size	活塞杆螺纹尺寸 Piston Port Size	可选用附件 Available Accessories	派生型号 Derivative Model	说明 Notes
		SMAL16	16	M5	M6 × 1	FA-前法兰 SDB-铰耳固定架 LB-双脚架 FA-Front Flange SDB-Hinge Ear Bracket LB-Foot Bracket	SMAL: 复动型 SMSAL: 单动伸出型 SMTAL: 单动引入型 SMADL: 双轴复动型 SMAJL: 双轴复动行程可调型 SMAL: Double Acting SMTAL: Single Acting Spring Pull SMTAL: Single Acting Spring Push SMADL: Double Rods Double Acting SMAJL: Double Rods Double Acting Adjustable
SMAL20	20	PT1/8	M8 × 1.25				
SMAL25	25	PT1/8	M10 × 1.25				
SMAL32	32	PT1/8	M10 × 1.25				
SMAL40	40	PT1/4	M12 × 1.25				

MA系列不锈钢迷你气缸 MA Series Stainless Steel Slim Cylinder

Operating Pressure: 使用压力:0~0.8Mpa	型号 Model	缸径 Bore	接管尺寸 Port Size	活塞杆螺纹尺寸 Piston Port Size	可选用附件 Available Accessories	派生型号 Derivative Model	说明 Notes
		MA16	16	M5	M6 × 1	FA-前法兰 LB-双脚架 FB-后法兰 Y-Y接头 CA-单悬耳 I-接头 CB-双悬耳 FA-Front Flange FB-Rear Flange CA-Single Clevis CB-Double Clevis LB-Foot Bracket Y-Y Joint I-I Joint	MA: 复动型 MSA: 单动伸出型 MAD: 双轴复动型 MAJ: 双轴复动行程可调型 MAR: 直接安装型 MAC: 复动缓冲可调型 MACD: 双轴复动缓冲可调型 MACJ: 双轴复动缓冲可调型 MTA: 单动引入型 MA: Double Acting MSA: Single Acting Spring Pull MAD: Double Rods Double Acting MAJ: Double Rods Double Acting Adjustable MAR: Direct Installation MAC: Double Acting With Cushion MACD: Double Rod With Cushion MACJ: Adjustable Stroke With Cushion MTA: Single Acting Spring Push
MA20	20	PT1/8	M8 × 1.25				
MA25	25	PT1/8	M10 × 1.25				
MA32	30	PT1/8	M10 × 1.25				
MA40	40	PT1/8	M12 × 1.25				

MG系列不锈钢迷你气缸 MG Series Stainless Steel Slim Cylinder

Operating Pressure: 使用压力:0~0.8Mpa	型号 Model	缸径 Bore	接管尺寸 Port Size	活塞杆螺纹尺寸 Piston Port Size	可选用附件 Available Accessories	派生型号 Derivative Model	说明 Notes
		MG20	20	M5	M8 × 1.25	FA-前法兰 LB-双脚架 SDB-铰耳固定架 FA-Front Flange LB-Foot Bracket CB-Double Clevis SDB-Hinge Ear Bracket	MG: 复动型 MSG: 单动伸出型 MTG: 单动引入型 MGD: 双轴复动型 MGC: 复动缓冲可调型 MGCD: 双轴复动缓冲可调型 MG: Double Acting MSG: Single Acting Spring Pull MTG: Single Acting Spring Push MGD: Double Rods Double Acting MGC: Double Acting With Cushion MGCD: Double Rod With Cushion
MG25	25	PT1/8	M10 × 1.25				
MG32	32	PT1/8	M10 × 1.25				
MG40	40	PT1/8	M14 × 1.5				
MG50	50	PT1/4	M18 × 1.5				
MG63	63	PT1/4	M18 × 1.5				

MI系列不锈钢迷你气缸 MI Series Stainless Steel Slim Cylinder

Operating Pressure: 使用压力:0~0.8Mpa	型号 Model	缸径 Bore	接管尺寸 Port Size	活塞杆螺纹尺寸 Piston Port Size	可选用附件 Available Accessories	派生型号 Derivative Model	说明 Notes
		MI8	8	M5	M4 × 0.7	FA-前法兰 SDB-铰耳固定架 LB-双脚架 FA-Front Flange SDB-Hinge Ear Bracket LB-Foot Bracket	MI: 复动型 MTI: 单动引入型 MSI: 单动伸出型 MID: 双轴复动型 MIJ: 双轴复动行程可调型 MIC: 复动缓冲可调型 MICD: 双轴复动缓冲可调型 MI: Double Acting MTI: Single Acting Spring Push MSI: Single Acting Spring Pull MID: Double Rods Double Acting MIJ: Double Rods Double Acting Adjustable MIC: Double Acting With Cushion MICD: Double Rod With Cushion
MI10	10	M5	M4 × 0.7				
MI12	12	M5	M6 × 1.0				
MI16	16	M5	M6 × 1.0				
MI20	20	PT1/8	M8 × 1.25				
MI25	25	PT1/8	M10 × 1.25				
MI32	32	PT1/8	M10 × 1.25				
MI40	40	PT1/4	M12 × 1.25				

DA系列直接安装型不锈钢迷你气缸 DA Series Direct Installation Stainless Steel Mini Cylinder

Operating Pressure: 使用压力:0~0.8Mpa	型号 Model	缸径 Bore	接管尺寸 Port Size	活塞杆螺纹尺寸 Piston Port Size	可选用附件 Available Accessories	派生型号 Derivative Model	说明 Notes
		DA20	20	PT1/8	M8 × 1.25	1: 双脚支架型 3: 法兰型 11: 尾部耳轴型 12: 活塞杆耳轴型 1: Double Foot Mounting Type 3: Flange Mounting Type 11: Head Trunnion Type 12: Rod Trunnion Type	SA: 单轴单动行 DA: 单轴复动型 DAB: 直接安装型 SA: Single Rod Single Acting DA: Single Rod Double Acting DAB: Direct Installation
DA25	25	PT1/8	M10 × 1.25				
DA32	32	PT1/8	M10 × 1.25				
DA40	40	PT1/8	M14 × 1.5				
DA50	50	PT1/4	M14 × 1.5				

ADN/AEN系列超薄气缸 AND/AEN Series Compact Cylinder

Operating Pressure: 使用压力:0~0.8Mpa 	型号 Model	缸径 Bore	接管尺寸 Port Size	活塞杆螺纹尺寸 Piston Port Size	可选用附件 Available Accessories	派生型号 Derivative Model	说明 Notes	
	ADN12	12	M5	M3	FNC-前法兰 SNCL-单悬耳 SNCB-双悬耳 LNG-斜单耳 HNC-双脚架 ZNC-前端盖中横 ZNCM-中间摆轴 FNC-Front Flange SNCL-Single Clevis SNCB-Double Clevis LNG-Oblique Single Ear HNC-Foot Bracket ZNC-Center Trunnion ZNCM-Front End Cap Pendulum LNG-Oblique Single Ear	ADN:单轴复动型 AEN:单动伸出型 AENZ:单动伸入型 ADN-S2:双轴复动型 ADN-S3:双轴复动伸出行程可调型	螺纹类型: -PT: PT螺纹 -NPT: NPT 螺纹 -G: G螺纹	
	ADN16	16	M5	M4		ADN: Single Rod Double Acting AEN: Single Acting Spring Pull AENZ: Single Acting Spring Push ADN-S2: Double Rods Double Acting ADN-S3: Double Rods Double Acting Adjustable	Thread Type: -PT: PT Thread -NPT: NPT Thread -G: G Thread	
	ADN20	20	M5	M6				
	ADN25	25	M5	M6				
	ADN32	32	G1/8	M8				
	ADN40	40	G1/8	M8				
	ADN50	50	G1/8	M10				
	ADN63	63	G1/8	M10				
	ADN80	80	G1/8	M12				
	ADN100	100	G1/8	M12				
ADN125	125	G1/4	M16					

ADVC/AEVC系列超薄气缸 ADVC/AEVC Series Compact Cylinder

Operating Pressure: 使用压力:0~0.8Mpa 	型号 Model	缸径 Bore	接管尺寸 Port Size	活塞杆螺纹尺寸 Piston Port Size	可选用附件 Available Accessories	派生型号 Derivative Model	说明 Notes	
	ADVC4	4	M3	-	FNC-前法兰 SNCL-单悬耳 SNCB-双悬耳 LNG-斜单耳 HNC-双脚架 ZNC-前端盖中横 ZNCM-中间摆轴 FNC-Front Flange SNCL-Single Clevis SNCB-Double Clevis LNG-Oblique Single Ear HNC-Foot Bracket ZNC-Center Trunnion ZNCM-Front End Cap Pendulum LNG-Oblique Single Ear	ADVC:复动短行程气缸 AEVC:单动短行程气缸	螺纹类型: -PT: PT螺纹 -NPT: NPT 螺纹 -G: G螺纹	
	ADVC6	6	M3	-		ADVC: Double Acting Short Stroke Cylinder AEVC: Single Acting Short Stroke Cylinder	Thread Type: -PT: PT Thread -NPT: NPT Thread -G: G Thread	
	ADVC10	10	M5	-				
	ADVC12	12	M5	M3				
	ADVC16	16	M5	M4				
	ADVC20	20	M5	M5				
	ADVC25	25	M5	M5				
	ADVC32	32	G1/8	M6				
	ADVC40	40	G1/8	M6				
	ADVC50	50	G1/8	M8				
ADVC63	63	G1/8	M8					
ADVC80	80	G1/8	M10					
ADVC100	100	G1/4	M12					

ADVU系列超薄气缸 ADVU Series Compact Cylinder

Operating Pressure: 使用压力:0~0.8Mpa 	型号 Model	缸径 Bore	接管尺寸 Port Size	活塞杆螺纹尺寸 Piston Port Size	可选用附件 Available Accessories	派生型号 Derivative Model	说明 Notes	
	ADVU12	12	M5	M3	FNC-前法兰 SNCL-单悬耳 SNCB-双悬耳 LNG-斜单耳 HNC-双脚架 ZNC-前端盖中横 ZNCM-中间摆轴 FNC-Front Flange SNCL-Single Clevis SNCB-Double Clevis LNG-Oblique Single Ear HNC-Foot Bracket ZNC-Center Trunnion ZNCM-Front End Cap Pendulum LNG-Oblique Single Ear	ADVU:单轴复动型 AEVU:单动伸出型 AEVUZ:单动伸入型 ADVU-S2:双轴复动型 ADVU-S3:双轴复动伸出行程可调型	螺纹类型: -PT: PT螺纹 -NPT: NPT 螺纹 -G: G螺纹	
	ADVU16	16	M5	M4		ADVU: Single Rod Double Acting AEVU: Single Acting Spring Pull AEVUZ: Single Acting Spring Push ADVU-S2: Double Rods Double Acting ADVU-S3: Double Rods Double Acting Adjustable	Thread Type: -PT: PT Thread -NPT: NPT Thread -G: G Thread	
	ADVU20	20	M5	M5				
	ADVU25	25	M5	M5				
	ADVU32	32	G1/8	M6				
	ADVU40	40	G1/8	M6				
	ADVU50	50	G1/8	M8				
	ADVU63	63	G1/8	M8				
	ADVU80	80	G1/8	M10				
	ADVU100	100	G1/4	M12				
ADVU125	125	G1/4	M16					

DMM系列紧凑自由安装气缸 DMM Series Compact Free Installation Cylinder

Operating Pressure: 使用压力: 0.1 ~ 1 Mpa 	型号 Model	缸径 Bore	接管尺寸 Port Size	活塞杆螺纹尺寸 Piston Port Size	可选用附件 Available Accessories	派生型号 Derivative Model	说明 Notes		
	DMM10	10	M3	M4	—	DMM:基本型 DML:抗扭矩型 DMM: Standard Type DML: Non-rotating Rod Type	螺纹类型: -PT: PT螺纹 -NPT: NPT 螺纹 -G: G螺纹		
	DMM16	16	M5	M6			Thread Type: -PT: PT Thread -NPT: NPT Thread -G: G Thread		
	DMM20	20	M5	M8					
	DMM25	25	M5	M10 × 1.25					
	DMM32	32	G1/8	M10 × 1.25					

CQSB系列薄型气缸 CQSB Series Compact Cylinder

Operating Pressure: 使用压力: 0.1 ~ 1 Mpa 	型号 Model	缸径 Bore	接管尺寸 Port Size	活塞杆螺纹尺寸 Piston Port Size	可选用附件 Available Accessories	派生型号 Derivative Model	说明 Notes	
	CQSB12	12	M5	M3 × 0.5 M5 × 0.8	B-基本型 D-双悬耳 F-前法兰 L-双脚架 A-两端螺孔式 G-无杆侧法兰 B-Standard D-Double Clevis F-Front Flange L-Foot Bracket A-Both Ends Tapped G-Rodless Side Flange	CQS:不带磁 CQQS:带磁性 CQSW:双轴型 CQSB-XC8:双轴可调型	螺纹类型: -PT: PT螺纹 -NPT: NPT 螺纹 -G: G螺纹	
	CQSB16	16	M5	M4 × 0.7 M6 × 1		CQS: No Magnet CQQS: With Magnet CQSW: Double Rods CQSB-XC8: Double Rods Adjustable	Thread Type: -PT: PT Thread -NPT: NPT Thread -G: G Thread	
	CQSB20	20	M5	M5 × 0.8 M8 × 1.25				
	CQSB25	25	M5	M6 × 1 M10 × 1.25				

CQ2B系列薄型气缸 CQ2B Series Compact Cylinder

Operating Pressure: 使用压力:0~0.8Mpa	型号 Model	缸径 Bore	接管尺寸 Port Size	活塞杆螺纹尺寸 Piston Port Size	可选用附件 Available Accessories	派生型号 Derivative Model	说明 Notes
	CQ2B12	12	M5	M3×0.5 M5×0.8	B-基本型 D-双悬耳 F-前法兰 L-双脚架 A-两端螺孔式 G-无杆侧法兰 B-Standard D-Double Clevis F-Front Flange L-Foot Bracket A-Both Ends Tapped G-Rodless Side Flange	CQ2:不带磁 CDQ2B:带磁性 CQ2WB:双轴型 CQ2B-XC8:双轴可调型 CD2:No Magnet CDQ2B:With Magnet CQ2WB:Double Rods CQ2B-XC8:Double Rods Adjustable	螺纹类型: -PT: PT螺纹 -NPT: NPT 螺纹 -G: G螺纹 Thread Type: -PT: PT Thread -NPT: NPT Thread -G: G Thread
	CQ2B16	16	M5	M4×0.7 M6×1			
	CQ2B20	20	M5	M5×0.8 M8×1.25			
	CQ2B25	25	M5	M6×1 M10×1.25			
	CQ2B32	32	G1/8	M8×1.25 M14×1.5			
	CQ2B40	40	G1/8	M8×1.25 M14×1.5			
	CQ2B50	50	G1/4	M10×1.5 M18×1.5			
	CQ2B63	63	G1/4	M10×1.5 M18×1.5			
	CQ2B80	80	G3/8	M16×2 M22×1.5			
	CQ2B100	100	G3/8	M20×2.5 M26×1.5			
	CQ2B125	125	G3/8	M22×2.5 M30×1.5			
	CQ2B140	140	G3/8	M22×2.5 M30×1.5			
CQ2B160	160	G3/8	M24×3 M30×1.5				

CQMB系列带导杆超薄气缸 CQMB Series Guide Rod Type Compact Cylinder

Operating Pressure: 使用压力:0~0.8Mpa	型号 Model	缸径 Bore	接管尺寸 Port Size	活塞杆螺纹尺寸 Piston Port Size	可选用附件 Available Accessories	派生型号 Derivative Model	说明 Notes
	CQMB12	12	M5	M3×0.5 M4×0.7	—	CQM:不带磁 CDQM:带磁性 CQM:No Magnet CDQM:With Magnet	螺纹类型: -PT: PT螺纹 -NPT: NPT 螺纹 -G: G螺纹 Thread Type: -PT: PT Thread -NPT: NPT Thread -G: G Thread
	CQMB16	16	M5	M3×0.5 M4×0.7			
	CQMB20	20	M5	M4×0.7 M6×1			
	CQMB25	25	M5	M5×0.8 M6×1			
	CQMB32	32	M5	M5×0.8 M6×1			
	CQMB40	40	PT1/8	M5×0.8 M6×1			
	CQMB50	50	PT1/4	M6×1 M8×1.25			
	CQMB63	63	PT1/4	M6×1 M10×1.5			
	CQMB80	80	PT3/8	M8×1.25 M12×1.75			
	CQMB100	100	PT3/8	M10×1.5 M12×1.75			

RQ系列超薄气缸 RQ Series Compact Cylinder

Operating Pressure: 使用压力: 0.1~1 Mpa	型号 Model	缸径 Bore	接管尺寸 Port Size	活塞杆螺纹尺寸 Piston Port Size	可选用附件 Available Accessories	派生型号 Derivative Model	说明 Notes
	RDQB20	20	M5	M5×0.8	B-基本型 D-双悬耳 F-前法兰 L-双脚架 A-两端螺孔式 G-无杆侧法兰 B-Standard D-Double Clevis F-Front Flange L-Foot Bracket A-Both Ends Tapped G-Rodless Side Flange	RQ:不带磁 RDQ:带磁性 RQ:No Magnet RDQ:With Magnet	螺纹类型: -PT: PT螺纹 -NPT: NPT 螺纹 -G: G螺纹 Thread Type: -PT: PT Thread -NPT: NPT Thread -G: G Thread
	RDQB25	25	M5	M6×1.0			
	RDQB32	32	PT1/8	M8×1.25			
	RDQB40	40	PT1/8	M8×1.25			
	RDQB50	50	PT1/4	M10×1.5			
	RDQB63	63	PT1/4	M10×1.5			
	RDQB80	80	PT3/8	M16×2			
	RDQB100	100	PT3/8	M20×2.5			

CU系列自由安装型气缸 CU Series Free Installation Cylinder

Operating Pressure: 使用压力: 0.1~1 Mpa	型号 Model	缸径 Bore	接管尺寸 Port Size	活塞杆螺纹尺寸 Piston Port Size	可选用附件 Available Accessories	派生型号 Derivative Model	说明 Notes
	CU 6	6	M5	M3×0.5	Y-Y接头 I-I接头 Y-Y Joint I-I Joint	CU:不带磁 CDU:带磁性 CUK:活塞杆不回转型 CUW:双轴型 CUKW:双轴型活塞杆不回转型 CU:No Magnet CDU:With Magnet CUK:Non-Rotating Rod CUW:Double Rods CUKW:Double Rods & Non-Rotating Rod	螺纹类型: -PT: PT螺纹 -NPT: NPT 螺纹 -G: G螺纹 Thread Type: -PT: PT Thread -NPT: NPT Thread -G: G Thread
	CU 10	10	M5	M4×0.7			
	CU 16	16	M5	M5×0.8			
	CU 20	20	M5	M6×1			
	CU 25	25	M5	M8×1.25			
	CU 32	32	G1/8	M10×1.25			

CUJB系列小型自由安装型气缸 CUJB Series Mini Type Free Installation Cylinder

Operating Pressure: 使用压力: 0.1~1 Mpa	型号 Model	缸径 Bore	接管尺寸 Port Size	活塞杆螺纹尺寸 Piston Port Size	可选用附件 Available Accessories	派生型号 Derivative Model	说明 Notes
	CUJB6	6	M3×0.5	M3×0.5	Y-Y接头 I-I接头 Y-Y Joint I-I Joint	CUJ:不带磁 CDUJ:带磁性 CUJ:No Magnet CDUJ:With Magnet	螺纹类型: -PT: PT螺纹 -NPT: NPT 螺纹 -G: G螺纹 Thread Type: -PT: PT Thread -NPT: NPT Thread -G: G Thread
	CUJB8	8	M3×0.5	M4×0.7			
	CUJB10	10	M3×0.5	M5×0.8			

ZCUK系列真空用自由安装型气缸 ZCUK Series Vacuum Free Installation Cylinder

Operating Pressure: 使用压力: 0.1~1 Mpa	型号 Model	缸径 Bore	接管尺寸 Port Size	活塞杆螺纹尺寸 Piston Port Size	可选用附件 Available Accessories	衍生型号 Derivative Model	说明 Notes
	ZCUK 10	10	M5	M4 × 0.7	—	ZCUK:不带磁 ZCUIK:带磁性 ZCUKC:缸盖外螺纹 ZCUKD:缸盖直接安装吸盘 ZCUKQ:活塞杆外螺纹 ZCUKR:活塞杆直接安装吸盘 ZCUK: No Magnet ZCUIK: With Magnet ZCUKC: Cap Piping Male Thread ZCUKD: Cap Piping Pad Direct Mounting ZCUKQ: Rod Piping Male Thread ZCUKR: Pad Direct Mounting	螺纹类型: -PT: PT螺纹 -NPT: NPT螺纹 -G: G螺纹 Thread Type: -PT: PT Thread -NPT: NPT Thread -G: G Thread
	ZCUK 16	16	M5	M5 × 0.8			
	ZCUK 20	20	M5	M6 × 1			
	ZCUK 25	25	M5	M8 × 1.25			
	ZCUK 32	32	Rc1/8	M10 × 1.25			

BDA系列自由安装气缸 BDA Series Free Installation Cylinder

Operating Pressure: 使用压力: 0~0.8Mpa	型号 Model	缸径 Bore	接管尺寸 Port Size	活塞杆螺纹尺寸 Piston Port Size	可选用附件 Available Accessories	衍生型号 Derivative Model	说明 Notes
	BDA6	6	M5 × 0.8	M3 × 0.5	—	BSA: 单轴推出单作用型 BTA: 单轴压入单作用型 BDAD: 双轴双动型 BDAS: 带磁性 BSA: Single Acting Spring Pull BTA: Single Acting Spring Push BDAD: Double Rods Double Acting BDAS: With Magnet	螺纹类型: -PT: PT螺纹 -NPT: NPT螺纹 -G: G螺纹 Thread Type: -PT: PT Thread -NPT: NPT Thread -G: G Thread
	BDA10	10	M5 × 0.8	M4 × 0.7			
	BDA16	16	M5 × 0.8	M5 × 0.8			

MBDA系列自由安装气缸 MBDA Series Free Installation Cylinder

Operating Pressure: 使用压力: 0~0.8Mpa	型号 Model	缸径 Bore	接管尺寸 Port Size	活塞杆螺纹尺寸 Piston Port Size	可选用附件 Available Accessories	衍生型号 Derivative Model	说明 Notes
	MBDA4.5	4.5	M3 × 0.5	M2 × 0.4	—	MBDA: 单轴双动型 MBSA: 单轴推出单作用型 MB-S: 带磁性 MBDA: Single Rod Double Acting MBSA: Single Acting Spring Pull MB-S: With Magnet	螺纹类型: -PT: PT螺纹 -NPT: NPT螺纹 -G: G螺纹 Thread Type: -PT: PT Thread -NPT: NPT Thread -G: G Thread
	MBDA6	6	M3 × 0.5	M3 × 0.5			
	MBDA10	10	M3 × 0.5	M3 × 0.5			
	MBDA16	16	M3 × 0.5	M4 × 0.7			

ACQ/TACQ系列薄型气缸 ACQ/TACQ Series Compact Cylinder

Operating Pressure: 使用压力: 0~0.8Mpa	型号 Model	缸径 Bore	接管尺寸 Port Size	活塞杆螺纹尺寸 Piston Port Size	可选用附件 Available Accessories	衍生型号 Derivative Model	说明 Notes
	ACQ12	12	M5	M3 × 0.5 M4 × 0.7	FA-前法兰 FB-后法兰 CB-双悬耳 LB-双脚架 FA-Front Flange FB-Rear Flange CB-Double Clevis LB-Foot Bracket	ACQ: 双动型 ASQ: 单动伸出型 ATQ: 单动引入型 ACQD: 双轴双动型 ACQJ: 双轴双动行程可调型 TACQ: 双轴带导杆型 ACQ: Double Acting ASQ: Single Acting Spring Pull ATQ: Single Acting Spring Push ACQD: Double Rods Double Acting ACQJ: Double Rods Double Acting Adjustable TACQ: Double Acting With Guide	螺纹类型: -PT: PT螺纹 -NPT: NPT螺纹 -G: G螺纹 Thread Type: -PT: PT Thread -NPT: NPT Thread -G: G Thread
	ACQ16	16	M5	M4 × 0.7 M4 × 0.7			
	ACQ20	20	M5	M5 × 0.8 M6 × 1			
	ACQ25	25	M5	M6 × 1 M6 × 1			
	ACQ32	32	PT1/8	M8 × 1.25 M6 × 1			
	ACQ40	40	PT1/8	M8 × 1.25 M6 × 1			
	ACQ50	50	PT1/4	M10 × 1.5 M8 × 1.25			
	ACQ63	63	PT1/4	M10 × 1.5 M10 × 1.25			
	ACQ80	80	PT3/8	M16 × 2.0 M12 × 1.75			
	ACQ100	100	PT3/8	M20 × 2.5 M12 × 1.75			
	ACQ125	125	PT3/8	M22 × 2.5 M14 × 2.0			
	ACQ140	140	PT3/8	M22 × 2.5 M14 × 2.0			
	ACQ160	160	PT3/8	M24 × 3.0 M16 × 2.0			

ACP系列超薄气缸 ACP Series Compact Cylinder

Operating Pressure: 使用压力: 0~0.8Mpa	型号 Model	缸径 Bore	接管尺寸 Port Size	活塞杆螺纹尺寸 Piston Port Size	可选用附件 Available Accessories	衍生型号 Derivative Model	说明 Notes
	ACP12	12	M5	M3 × 0.5	FA-前法兰 FB-后法兰 CB-双悬耳 LB-双脚架 FA-Front Flange FB-Rear Flange CB-Double Clevis CA-Single Clevis LB-Foot Bracket	ACP: 双动型 ASP: 单动伸出型 ATP: 单动引入型 ACPD: 双轴双动型 ACPJ: 双轴双动行程可调型 ACP: Double Acting ASP: Single Acting Spring Pull ATP: Single Acting Spring Push ACPD: Double Rods Double Acting ACPJ: Double Rods Double Acting Adjustable	螺纹类型: -PT: PT螺纹 -NPT: NPT螺纹 -G: G螺纹 Thread Type: -PT: PT Thread -NPT: NPT Thread -G: G Thread
	ACP16	16	M5	M4 × 0.7			
	ACP20	20	M5	M5 × 0.8			
	ACP25	25	M5	M5 × 0.8			
	ACP32	32	G1/8	M6 × 1.0			
	ACP40	40	G1/8	M6 × 1.0			
	ACP50	50	G1/8	M8 × 1.25			
	ACP63	63	G1/8	M8 × 1.25			
	ACP80	80	G1/8	M10 × 1.5			
	ACP100	100	G1/4	M12 × 1.75			

SSDA系列不锈钢薄型气缸 SSDA Series Stainless Steel Compact Cylinder

Operating Pressure: 使用压力:0~0.8Mpa	型号 Model	缸径 Bore	接管尺寸 Port Size	活塞杆螺纹尺寸 Piston Port Size		可选用附件 Available Accessories	派生型号 Derivative Model	说明 Notes
	SSDA12	12	M5	M3×0.5	M5×0.8	FA-前法兰 FB-后法兰 CA-单悬耳 CB-双悬耳 LB-双脚架	SSDA: 复动型 SSSA: 单动伸出型 SSTA: 单动引入型 SSDAD: 双轴复动型 SSDAJ: 双轴复动行程可调型 SSDAT: 复动多位型 SSDAW: 双轴复动多位型	螺纹类型: -PT: PT螺纹 -NPT: NPT螺纹 -G: G螺纹
	SSDA16	16	M5	M3×0.5	M5×0.8			
	SSDA20	20	M5	M4×0.7	M5×0.8			
	SSDA25	25	M5	M5×0.8	M6×1			
	SSDA32	32	G1/8	M6×1	M6×1			
	SSDA40	40	G1/8	M8×1.25	M8×1.25			
	SSDA50	50	G1/4	M10×1.5	M8×1.25			
	SSDA63	63	G1/4	M10×1.5	M8×1.25			
	SSDA80	80	G3/8	M14×1.5	M12×1.75			
	SSDA100	100	G3/8	M18×1.5	M14×2.0			
						FA-Front Flange FB-Rear Flange CA-Single Clevis CB-Double Clevis LB-Foot Bracket	SSDA: Double Acting SSSA: Single Acting Spring Pull SSTA: Single Acting Spring Push SSDAD: Double Rods Double Acting SSDAJ: Double Rods Double Acting Adjustable SSDAT: Duplex Type SSDAW: Duplex End Type	Thread Type: -PT: PT Thread -NPT: NPT Thread -G: G Thread

SDA系列薄型气缸 SDA Series Compact Cylinder

Operating Pressure: 使用压力:0~0.8Mpa	型号 Model	缸径 Bore	接管尺寸 Port Size	活塞杆螺纹尺寸 Piston Port Size		可选用附件 Available Accessories	派生型号 Derivative Model	说明 Notes
	SDA12	12	M5	M3×0.5	M5×0.8	FA-前法兰 FB-后法兰 CA-单悬耳 CB-双悬耳 LB-双脚架	SDA: 复动型 SSA: 单动伸出型 STA: 单动引入型 SDAD: 双轴复动型 SDAJ: 双轴复动行程可调型 SDAT: 复动多位型 SDAW: 双轴复动多位型	螺纹类型: -PT: PT螺纹 -NPT: NPT螺纹 -G: G螺纹
	SDA16	16	M5	M3×0.5	M5×0.8			
	SDA20	20	M5	M4×0.7	M5×0.8			
	SDA25	25	M5	M5×0.8	M6×1			
	SDA32	32	G1/8	M6×1	M6×1			
	SDA40	40	G1/8	M8×1.25	M8×1.25			
	SDA50	50	G1/4	M10×1.5	M8×1.25			
	SDA63	63	G1/4	M10×1.5	M8×1.25			
	SDA80	80	G3/8	M14×1.5	M12×1.75			
	SDA100	100	G3/8	M18×1.5	M14×2.0			
						FA-Front Flange FB-Rear Flange CA-Single Clevis CB-Double Clevis LB-Foot Bracket	SDA: Double Acting SSA: Single Acting Spring Pull STA: Single Acting Spring Push SDAD: Double Rods Double Acting SDAJ: Double Rods Double Acting Adjustable SDAT: Duplex Type SDAW: Duplex End Type	Thread Type: -PT: PT Thread -NPT: NPT Thread -G: G Thread

SSD2系列薄型气缸 SSD2 Series Compact Cylinder

Operating Pressure: 使用压力:0~0.8Mpa	型号 Model	缸径 Bore	接管尺寸 Port Size	活塞杆螺纹尺寸 Piston Port Size		可选用附件 Available Accessories	派生型号 Derivative Model	说明 Notes
	SSD2 12	12	M5	M3		FA-前法兰 FB-后法兰 CB-双悬耳 LB-双脚架	SSD2: 单轴复动不带磁 SSD2-L: 单轴复动带磁性	螺纹类型: -PT: PT螺纹 -NPT: NPT螺纹 -G: G螺纹
	SSD2 16	16	M5	M4				
	SSD2 20	20	M5	M5				
	SSD2 25	25	M5	M6				
	SSD2 32	32	PT1/8	M8				
	SSD2 40	40	PT1/8	M8				
	SSD2 50	50	PT1/4	M10				
	SSD2 63	63	PT1/4	M10				
	SSD2 80	80	PT3/8	M16				
	SSD2 100	100	PT3/8	M20				
						FA-Front Flange FB-Rear Flange CB-Double Clevis LB-Foot Bracket	SSD2: Single Rod Double Acting & No Magnet SSD2: Single Rod Double Acting & With Magnet	Thread Type: -PT: PT Thread -NPT: NPT Thread -G: G Thread

DPZ系列双活塞杆气缸 DPZ Series Double Piston Rods Guide Cylinder

Operating Pressure: 使用压力:0~0.8Mpa	型号 Model	缸径 Bore	接管尺寸 Port Size	活塞杆螺纹尺寸 Piston Port Size		可选用附件 Available Accessories	派生型号 Derivative Model	说明 Notes
	DPZ10	10	M5	6		DPZ: 双活塞气缸, 带一块联接板 DPZJ: 双活塞气缸, 带两块联接板 DP-GF: 滑动轴承导轨 DP-KF: 循环滚珠轴承导轨	DPZ: Twin Cylinder with One Yoke Plate DPZJ: Twin Cylinder with through Piston Rods and Two Yoke Plates DP-GF: Plain Bearing Guide DP-KF: Recirculating Ball Bearing Guide	螺纹类型: -PT: PT螺纹 -NPT: NPT螺纹 -G: G螺纹
	DPZ16	16	M5	8				
	DPZ20	20	M5	10				
	DPZ25	25	M5	12				
	DPZ32	32	G1/8	16				
								Thread Type: -PT: PT Thread -NPT: NPT Thread -G: G Thread

CXW系列双活塞杆气缸 CXW Series Double Piston Rods Guide Cylinder

Operating Pressure: 使用压力:0~0.8Mpa	型号 Model	缸径 Bore	接管尺寸 Port Size	活塞杆螺纹尺寸 Piston Port Size		可选用附件 Available Accessories	派生型号 Derivative Model	说明 Notes
	CXW10	10	M5	6		—	CXW-M: 滑动轴承型 CXW-L: 球轴承型	螺纹类型: -PT: PT螺纹 -NPT: NPT螺纹 -G: G螺纹
	CXW16	16	M5	10				
	CXW20	20	M5	12				
	CXW25	25	G1/8	14				
	CXW32	32	G1/8	20				
								Thread Type: -PT: PT Thread -NPT: NPT Thread -G: G Thread

FENG-GF/FENG-KF系列导向装置 FENG-GF/FENG-KF Series Guiding Device

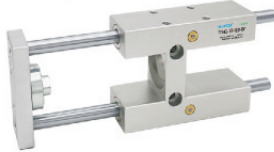
<p>Operating Pressure: 使用压力:0~0.8Mpa</p> 	型号 Model	缸径 Bore	接管尺寸 Port Size	活塞杆螺纹尺寸 Piston Port Size	可选用附件 Available Accessories	派生型号 Derivative Model	说明 Notes
	FENG-GF/KF 32	32	M6	M10 × 1.5	—	—	<p>螺纹类型: -PT: PT 螺纹 -NPT: NPT 螺纹 -G: G 螺纹</p> <p>Thread Type: -PT: PT Thread -NPT: NPT Thread -G: G Thread</p>
	FENG-GF/KF 40	40	M6	M12 × 1.5			
	FENG-GF/KF 50	50	M8	M16 × 1.5			
	FENG-GF/KF 63	63	M8	M16 × 1.5			
	FENG-GF/KF 80	80	M10	M20 × 1.5			
FENG-GF/KF 100	100	M10	M20 × 1.5				

DFM系列导向杆气缸 DFM Series Guide Rod Cylinder

<p>Operating Pressure: 使用压力:0~0.8Mpa</p> 	型号 Model	缸径 Bore	接管尺寸 Port Size	活塞杆螺纹尺寸 Piston Port Size	可选用附件 Available Accessories	派生型号 Derivative Model	说明 Notes
	DMF12	12	M5	10	—	<p>DFM-A:带磁性 DFM-P:两端带弹性缓冲垫 DFM-GF:滑动轴承导轨 DFM-KF:循环滚珠轴承导轨</p> <p>DFM-A:With Magnet DFM-P:Elastic Cushioning Rings/pads at Both Ends DFM-GF:Plain-bearing Guide DFM-KF:Recirculating Ball Bearing Guide</p>	<p>螺纹类型: -PT: PT 螺纹 -NPT: NPT 螺纹 -G: G 螺纹</p> <p>Thread Type: -PT: PT Thread -NPT: NPT Thread -G: G Thread</p>
	DMF16	16	M5	12			
	DMF20	20	M5	14			
	DMF25	25	G1/8	16			
	DMF32	32	G1/8	20			
	DMF40	40	G1/8	20			
	DMF50	50	G1/4	25			
	DMF63	63	G1/4	25			
	DMF80	80	G3/8	30			
DMF100	100	G3/8	35				

CXS系列双轴气缸 CXS Series Double Piston Rods Guide Cylinder

<p>Operating Pressure: 使用压力: 0.1 ~ 1 Mpa</p> 	型号 Model	缸径 Bore	接管尺寸 Port Size	活塞杆螺纹尺寸 Piston Port Size	可选用附件 Available Accessories	派生型号 Derivative Model	说明 Notes
	CXS6	6	M5	4	—	<p>CXS-M:滑动轴承型 CXS-L:球轴承型</p> <p>CXS-M:Slide Bearing CXS-L:Ball Bushing</p>	<p>螺纹类型: -PT: PT 螺纹 -NPT: NPT 螺纹 -G: G 螺纹</p> <p>Thread Type: -PT: PT Thread -NPT: NPT Thread -G: G Thread</p>
	CXS10	10	M5	6			
	CXS15	15	M5	8			
	CXS20	20	M5	10			
	CXS25	25	G1/8	12			
CXS32	32	G1/8	16				

CXSJ系列双联气缸 CXSJ Series Double Piston Rods Guide Cylinder

<p>Operating Pressure: 使用压力:0~0.8Mpa</p> 	型号 Model	缸径 Bore	接管尺寸 Port Size	活塞杆螺纹尺寸 Piston Port Size	可选用附件 Available Accessories	派生型号 Derivative Model	说明 Notes
	CXSJ6	6	M3 × 0.5	4	—	<p>CXSJ-M:滑动轴承型 CXSJ-L:球轴承型</p> <p>CXSJ-M:Slide Bearing CXSJ-L:Ball Bushing</p>	<p>螺纹类型: -PT: PT 螺纹 -NPT: NPT 螺纹 -G: G 螺纹</p> <p>Thread Type: -PT: PT Thread -NPT: NPT Thread -G: G Thread</p>
	CXSJ10	10	M3 × 0.8	6			
	CXSJ15	15	M3 × 0.8	8			
	CXSJ20	20	M3 × 0.8	10			
	CXSJ25	25	M3 × 0.8	12			
CXSJ32	32	PT1/8	16				

TB系列薄型带导杆气缸 TB Series Thin Type Guide Rod Cylinder

<p>Operating Pressure: 使用压力:0~0.8Mpa</p> 	型号 Model	缸径 Bore	接管尺寸 Port Size	活塞杆螺纹尺寸 Piston Port Size	可选用附件 Available Accessories	派生型号 Derivative Model	说明 Notes
	TB10	10	M5 × 0.8	M4 × 0.7	—	<p>TB:基本型 TAB:行程可调型 TRB:回程可调型</p> <p>TB: Standard TAB: Adjustable Stroke TRB: Retraction Adjustable Stroke</p>	<p>螺纹类型: -PT: PT 螺纹 -NPT: NPT 螺纹 -G: G 螺纹</p> <p>Thread Type: -PT: PT Thread -NPT: NPT Thread -G: G Thread</p>
	TB16	16	M5 × 0.8	M5 × 0.8			
	TB20	20	M5 × 0.8	M5 × 0.8			
	TB25	25	M5 × 0.8	M6 × 1			
	TB32	32	G1/8	M6 × 1			
	TB40	40	G1/8	M6 × 1			
	TB50	50	G1/4	M10 × 1.5			
TB63	63	G1/4	M10 × 1.5				

TD系列双活塞杆气缸 TD Series Double Piston Rods Guide Cylinder

Operating Pressure: 使用压力: 0.1~1 Mpa 	型号 Model	缸径 Bore	接管尺寸 Port Size	活塞杆螺纹尺寸 Piston Port Size	可选用附件 Available Accessories	派生型号 Derivative Model	说明 Notes
	TD 6	6	M3	4	—	—	螺纹类型: -PT: PT螺纹 -NPT: NPT 螺纹 -G: G螺纹 Thread Type: -PT: PT Thread -NPT: NPT Thread -G: G Thread
	TD 10	10	M5	6			
	TD 16	16	M5	8			
	TD 20	20	M5	10			
	TD 25	25	M5	12			
	TD 32	32	PT1/8	16			

MGP系列薄型带导杆气缸 MGP Series Thin Type Guide Cylinder

Operating Pressure: 使用压力:0~0.8Mpa 	型号 Model	缸径 Bore	接管尺寸 Port Size	活塞杆螺纹尺寸 Piston Port Size	挡板距离 Baffle Distance	派生型号 Derivative Model	说明 Notes
	MGPM/MGPL12	12	M5	M3×0.5, M5×0.8	56	MGPM:滑动轴承型 MGPL:球轴承型 MGPA:高精度球轴承型 MGPM:Sliding Bearings MGPL:Ball Bearings MGPA:High-Accuracy Ball Bearings	螺纹类型: -PT: PT螺纹 -NPT: NPT 螺纹 -G: G螺纹 Thread Type: -PT: PT Thread -NPT: NPT Thread -G: G Thread
	MGPM/MGPL16	16	M5	M3×0.5, M5×0.8	62		
	MGPM/MGPL20	20	M5	M4×0.7, M6×1	81		
	MGPM/MGPL25	25	M5	M5×0.8, M8×1.25	91		
	MGPM/MGPL32	32	G1/8	M6×1, M10×1.25	110		
	MGPM/MGPL40	40	G1/8	M8×1.25, M14×1.5	118		
	MGPM/MGPL50	50	G1/4	M10×1.5, M18×1.5	146		
MGPM/MGPL63	63	G1/4	M10×1.5, M18×1.5	158			

MGJ系列微型带导杆气缸 MGJ Series Micro Type Guide Cylinder

Operating Pressure: 使用压力:0~0.8Mpa 	型号 Model	缸径 Bore	接管尺寸 Port Size	活塞杆螺纹尺寸 Piston Port Size	挡板距离 Baffle Distance	可选用附件 Available Accessories	派生型号 Derivative Model	说明 Notes
	MGJ6	6	M3×0.5	M2.5×0.45	20.5	—	—	螺纹类型: -PT: PT螺纹 -NPT: NPT 螺纹 -G: G螺纹 Thread Type: -PT: PT Thread -NPT: NPT Thread -G: G Thread
	MGJ10	10	M3×0.5	M3×0.5	23			

TCM/TCL系列薄型带导杆气缸 TCM/TCL Series Thin Type Guide Cylinder

Operating Pressure: 使用压力:0~0.8Mpa 	型号 Model	型号 Model	缸径 Bore	接管尺寸 Port Size	活塞杆螺纹尺寸 Piston Port Size	挡板距离 Baffle Distance	派生型号 Derivative Model	说明 Notes
	TCM 6	TCL 6	6	M3	-	-	TCM:铜套轴承型 TCL:直线轴承型 TCM/TCL-J:行程可调型 TCM: Bronze Bearing TCL: Linear Bearing TCM/TCL-J: Stroke Adjustable	螺纹类型: -PT: PT螺纹 -NPT: NPT 螺纹 -G: G螺纹 Thread Type: -PT: PT Thread -NPT: NPT Thread -G: G Thread
	TCM 10	TCL 10	10	M3	-	-		
	TCM 12	TCL 12	12	M5	M3×0.5, M5×0.8	56		
	TCM 16	TCL 16	16	M5	M3×0.5, M5×0.8	62		
	TCM 20	TCL 20	20	PT1/8	M4×0.7, M6×1	81		
	TCM 25	TCL 25	25	PT1/8	M5×0.8, M8×1.25	91		
	TCM 32	TCL 32	32	PT1/8	M6×1, M10×1.25	110		
	TCM 40	TCL 40	40	PT1/8	M8×1.25, M14×1.5	118		
	TCM 50	TCL 50	50	PT1/4	M10×1.5, M18×1.5	146		
	TCM 63	TCL 63	63	PT1/4	M10×1.5, M18×1.5	158		
	TCM 80	TCL 80	80	PT3/8	-	-		
	TCM 100	TCL 100	100	PT3/8	-	-		

TN/TR系列双活塞杆气缸 TN/TR Series Double Piston Rods Guide Cylinder

Operating Pressure: 使用压力:0~0.8Mpa 	型号 Model	型号 Model	缸径 Bore	接管尺寸 Port Size	活塞杆螺纹尺寸 Piston Port Size	派生型号 Derivative Model	说明 Notes
	TN 6	TR 6	6	M5	4	TN 执行企业标准 TR 执行JIS企业标准 TN: Enterprise Standard TR: JIS Standard	螺纹类型: -PT: PT螺纹 -NPT: NPT 螺纹 -G: G螺纹 Thread Type: -PT: PT Thread -NPT: NPT Thread -G: G Thread
	TN 10	TR 10	10	M5	6		
	TN 16	TR 16	16	M5	8		
	TN 20	TR 20	20	M5	10		
	TN 25	TR 25	25	G1/8	12		
TN 32	TR 32	32	G1/8	16			

STM系列双活塞杆气缸 STM Series Double Piston Rods Cylinder

Operating Pressure: 使用压力:0~0.8Mpa	型号 Model	缸径 Bore	接管尺寸 Port Size	活塞杆螺纹尺寸 Piston Port Size	可选用附件 Available Accessories	派生型号 Derivative Model	说明 Notes
	STM10	10	M5	6	—	STM-B:本体固定型 STM-S:滑块固定型	螺纹类型: -PT: PT螺纹 -NPT: NPT 螺纹 -G: G螺纹 Thread Type: -PT: PT Thread -NPT: NPT Thread -G: G Thread
	STM16	16	M5	8			
	STM20	20	M5	10			
	STM25	25	PT1/8	12			

MGC系列带导杆气缸 MGC Series Guide Cylinder

Operating Pressure: 使用压力:0~0.8Mpa	型号 Model	缸径 Bore	接管尺寸 Port Size	活塞杆螺纹尺寸 Piston Port Size	可选用附件 Available Accessories	派生型号 Derivative Model	说明 Notes
	MGC20	20	M5×0.8	M6×1	B-基本型 F-前法兰	MGM:滑动轴承型 MGCL:球轴承型	螺纹类型: -PT: PT螺纹 -NPT: NPT 螺纹 -G: G螺纹 Thread Type: -PT: PT Thread -NPT: NPT Thread -G: G Thread
	MGC25	25	M5×0.8	M6×1			
	MGC32	32	PT1/8	M6×1			
	MGC40	40	PT1/8	M8×1.25	B-Standard F-Front Flange	MGM:Sliding Bearings MGCL:Ball Bearings	
	MGC50	50	PT1/4	M8×1.25			

MGG系列带导杆气缸 MGG Series Guide Cylinder

Operating Pressure: 使用压力:0~0.8Mpa	型号 Model	缸径 Bore	接管尺寸 Port Size	活塞杆螺纹尺寸 Piston Port Size	可选用附件 Available Accessories	派生型号 Derivative Model	说明 Notes
	MGG20	20	PT1/8	M6×1	B-基本型 F-前法兰	MGM:滑动轴承型 MGGL:球轴承型	螺纹类型: -PT: PT螺纹 -NPT: NPT 螺纹 -G: G螺纹 Thread Type: -PT: PT Thread -NPT: NPT Thread -G: G Thread
	MGG25	25	PT1/8	M6×1			
	MGG32	32	PT1/8	M6×1			
	MGG40	40	PT1/8	M8×1.25			
	MGG50	50	PT1/4	M10×1.5			
	MGG63	63	PT1/4	M12×1.75	B-Standard F-Front Flange	MGM:Sliding Bearings MGGL:Ball Bearings	
	MGG80	80	PT3/8	M12×1.75			
	MGG100	100	PT1/2	M14×2			

MY1系列机械式无杆气缸 MY1 Series Mechanical Type Rodless Cylinder

Operating Pressure: 使用压力:0~0.8Mpa	型号 Model	缸径 Bore	接管尺寸 Port Size	使用速度 Using Speed	可选用附件 Available Accessories	派生型号 Derivative Model	说明 Notes
	MY1-10	10	M5	100~1000 mm/s	—	MY1B:基本型 MY1M:滑动轴承导轨型 MY1C:凸轮随动导轨型 MY1H:直线导轨型 MY1HT:高刚性直线导轨型	螺纹类型: -PT: PT螺纹 -NPT: NPT 螺纹 -G: G螺纹 Thread Type: -PT: PT Thread -NPT: NPT Thread -G: G Thread
	MY1-16	16	M5				
	MY1-20	20	M5				
	MY1-25	25	G1/8				
	MY1-32	32	G1/8				
	MY1-40	40	G1/4				
	MY1-50	50	G3/8				
	MY1-63	63	G3/8				
	MY1-80	80	G1/2				
MY1-100	100	G1/2					

CY3B/CY3R系列磁耦合无杆气缸 CY3B/CY3R Series Magnetic Coupled Rodless Cylinder

Operating Pressure: 使用压力:0~0.8Mpa	型号 Model	型号 Model	缸径 Bore	接管尺寸 Port Size	使用速度 Using Speed	派生型号 Derivative Model	说明 Notes
	CY3B-6	CY3R-6	6	M5	50~500 mm/s	CY3B:基本型 CY3R:直接安装型	螺纹类型: -PT: PT螺纹 -NPT: NPT 螺纹 -G: G螺纹 Thread Type: -PT: PT Thread -NPT: NPT Thread -G: G Thread
	CY3B-10	CY3R-10	10	M5			
	CY3B-15	CY3R-15	15	M5			
	CY3B-20	CY3R-20	20	M5			
	CY3B-25	CY3R-25	25	PT1/8			
	CY3B-32	CY3R-32	32	PT1/8			
	CY3B-40	CY3R-40	40	PT1/4			
	CY3B-50	CY3R-50	50	PT1/4			
	CY3B-63	CY3R-63	63	PT1/4			

CY1S系列磁耦合无杆气缸 CY1S Series Magnetic Coupled Rodless Cylinder

Operating Pressure: 使用压力:0~0.8Mpa 	型号 Model	缸径 Bore	接管尺寸 Port Size	使用速度 Using Speed	派生型号 Derivative Model	说明 Notes
	CY1S-6	6	M3	50~400 mm/s	CY1S:带调整螺钉(2只) CY1S-B:带液压缓冲器(2只) CY1S-BS:带液压缓冲器(1只) CY1S:With Adjusting Bolt(2Pcs) CY1S-B:With Shock Absorbers(2Pcs) CY1S-BS:With Shock Absorbers(1Pcs)	螺纹类型: -PT: PT螺纹 -NPT: NPT 螺纹 -G: G螺纹 Thread Type: -PT: PT Thread -NPT: NPT Thread -G: G Thread
	CY1S-10	10	M5			
	CY1S-15	15	M5			
	CY1S-20	20	PT1/8			
	CY1S-25	25	PT1/8			
	CY1S-32	32	PT1/8			
	CY1S-40	40	PT1/4			

CY1L系列磁耦合无杆气缸 CY1L Series Magnetic Coupled Rodless Cylinder

Operating Pressure: 使用压力:0~0.8Mpa 	型号 Model	缸径 Bore	接管尺寸 Port Size	使用速度 Using Speed	派生型号 Derivative Model	说明 Notes
	CY1L-6	6	M5	50~1000 mm/s	CY1L:带调整螺钉(2只) CY1L-B:带液压缓冲器(2只) CY1L-BS:带液压缓冲器(1只) CY1L:With Adjusting Bolt(2Pcs) CY1L-B:With Shock Absorbers(2Pcs) CY1L-BS:With Shock Absorbers(1Pcs)	螺纹类型: -PT: PT螺纹 -NPT: NPT 螺纹 -G: G螺纹 Thread Type: -PT: PT Thread -NPT: NPT Thread -G: G Thread
	CY1L-10	10	M5			
	CY1L-15	15	M5			
	CY1L-20	20	PT1/8			
	CY1L-25	25	PT1/8			
	CY1L-32	32	PT1/8			
	CY1L-40	40	PT1/4			

RMS系列磁耦合无杆气缸 RMS Series Magnetic Coupled Rodless Cylinder

Operating Pressure: 使用压力:0~0.8Mpa 	型号 Model	缸径 Bore	接管尺寸 Using Speed	使用速度 Using Speed	可选用附件 Available Accessories	派生型号 Derivative Model	说明 Notes
	RMS-6	6	M5	50~500 mm/s	FA-前法兰 LB-双脚架 FA-Front Flange LB-Foot Bracket	RMS-基本型 RMS-P:尺寸规格P型 RMS-F:尺寸规格F型 RMS:Standard RMS-P:P Size Type RMS-F:P Size Type	螺纹类型: -PT: PT螺纹 -NPT: NPT 螺纹 -G: G螺纹 Thread Type: -PT: PT Thread -NPT: NPT Thread -G: G Thread
	RMS-10	10	M5				
	RMS-16	15	M5				
	RMS-20	20	M5				
	RMS-25	25	PT1/8				
	RMS-32	32	PT1/8				
	RMS-40	40	PT1/4				
	RMS-50	50	PT1/4				
RMS-63	63	PT1/4					

RMT/RMTL系列磁耦合无杆气缸 RMT/RMTL Series Magnetic Coupled Rodless Cylinder

Operating Pressure: 使用压力:0~0.8Mpa 	型号 Model	型号 Model	缸径 Bore	接管尺寸 Port Size	使用速度 Using Speed	派生型号 Derivative Model	说明 Notes
	RMT-10	RMTL-10	10	M5	RMT: 50~400 mm/s	RMT/RMTL:调整螺丝2只 RMT/RMTL-A:油压缓冲器2只 RMT/RMTL-S:带磁性 RMS/RMTL:With Two Pcs Adjustable Nuts RMS/RMTL-A:With Two Pcs Shock Absorbers RMS/RMTL-S:With Magnet	螺纹类型: -PT: PT螺纹 -NPT: NPT 螺纹 -G: G螺纹 Thread Type: -PT: PT Thread -NPT: NPT Thread -G: G Thread
	RMT-16	RMTL-16	15	M5			
	RMT-20	RMTL-20	20	PT1/8			
	RMT-25	RMTL-25	25	PT1/8	RMTL: 50~1000 mm/s		
	RMT-32	RMTL-32	32	PT1/8			
	RMT-40	RMTL-40	40	PT1/4			

MHL2系列气动手指 MHL2 Series Air Gripper

Operating Pressure: 使用压力:0~0.8Mpa 	双动型 Double Acting Type	缸径 Bore	闭合力 Closing Force	接管尺寸 Port Size	说明 Notes
	MHL2-10D	10	14N	M5 × 0.8	螺纹类型: -PT: PT螺纹 -NPT: NPT 螺纹 -G: G螺纹 Thread Type: -PT: PT Thread -NPT: NPT Thread -G: G Thread
	MHL2-16D	16	45N	M5 × 0.8	
	MHL2-20D	20	74N	M5 × 0.8	
	MHL2-25D	25	131N	M5 × 0.8	
	MHL2-32D	32	228N	G1/8	
	MHL2-40D	40	396N	G1/8	

MHF2系列气动手指 MHF2 Series Air Gripper

<p>Operating Pressure: 使用压力:0~0.8Mpa</p> 	双动型 Double Acting Type	缸径 Bore	闭合力 Close Force	接管尺寸 Port Size	说明 Notes
	MHF2-8D	8	19N	M3 × 0.5	螺纹类型: -PT: PT螺纹 -NPT: NPT 螺纹 -G: G螺纹
	MHF2-12D	12	48N	M4 × 0.7	
	MHF2-16D	16	90N	M5 × 0.8	Thread Type: -PT: PT Thread -NPT: NPT Thread -G: G Thread
	MHF2-20D	20	141N	M6 × 1	

MHC2系列气动手指 MHC2 Series Air Gripper

<p>Operating Pressure: 使用压力:0~0.8Mpa</p> 	双动型 Double Acting Type	闭合力 Closing Force	单动常开型 Single Acting Normally Open Type	闭合力 Closing Force	螺纹接口 Port Size	标准行程 Standard Stroke	动作频率 Frequency	说明 Notes
	MHC2-10D	9.8N	MHC2-10S	6.9N	M3 × 0.5	4MM	180 c.p.m.	螺纹类型: -PT: PT螺纹 -NPT: NPT 螺纹 -G: G螺纹
	MHC2-16D	39.2N	MHC2-16S	31.4N	M5 × 0.8	6MM	180 c.p.m.	
	MHC2-20D	69.7N	MHC2-20S	54N	M5 × 0.8	10MM	180 c.p.m.	Thread Type: -PT: PT Thread -NPT: NPT Thread -G: G Thread
	MHC2-25D	136N	MHC2-25S	108N	M5 × 0.8	14MM	180 c.p.m.	

MHT2系列气动手指 MHT2 Series Air Gripper

<p>Operating Pressure: 使用压力:0~0.8Mpa</p> 	双动型 Double Acting Type	缸径 Bore	闭合力 Close Force	接管尺寸 Port Size	说明 Notes
	MHT2-32D	32	12.4N	G1/8	螺纹类型: -PT: PT螺纹 -NPT: NPT 螺纹 -G: G螺纹
	MHT2-40D	40	36.0N	G1/4	
	MHT2-50D	50	63.0N	G1/4	Thread Type: -PT: PT Thread -NPT: NPT Thread -G: G Thread
	MHT2-63D	63	106N	G1/4	

MHY2系列气动手指 MHY2 Series Air Gripper

<p>Operating Pressure: 使用压力:0~0.8Mpa</p> 	双动型 Double Acting Type	缸径 Bore	闭合力 Close Force	接管尺寸 Port Size	说明 Notes
	MHY2-10D	10	0.16N	M5 × 08	螺纹类型: -PT: PT螺纹 -NPT: NPT 螺纹 -G: G螺纹
	MHY2-16D	16	0.54N	M5 × 08	
	MHY2-20D	20	1.10N	M5 × 08	Thread Type: -PT: PT Thread -NPT: NPT Thread -G: G Thread
	MHY2-25D	25	2.28N	M5 × 08	

MIW/MIS系列气动手指 MIW/MIS Series Air Gripper

<p>Operating Pressure: 使用压力:0~0.8Mpa</p> 	双动型 Double Acting Type	双动型 Double Acting Type	缸径 Bore	接管尺寸 Port Size	派生型号 Derivative Model	说明 Notes
	MIW-20D	MIS-20D	20	M3 × 0.5	MIW:双爪型 MIS:单爪型	螺纹类型: -PT: PT螺纹 -NPT: NPT 螺纹 -G: G螺纹
	MIW-25D	MIS-25D	25	M3 × 0.5		
	MIW-32D	MIS-32D	32	M5 × 0.8	MIW: Double Finger MIS: Single Finger	Thread Type: -PT: PT Thread -NPT: NPT Thread -G: G Thread
	MIW-40D	MIS-40D	40	M6 × 1		
	MIW-50D	MIS-50D	50	M8 × 1.25		

MHW2系列气动手指 MHW2 Series Air Gripper

<p>Operating Pressure: 使用压力:0~0.8Mpa</p> 	双动型 Double Acting Type	缸径 Bore	闭合力 Close Force	接管尺寸 Port Size	说明 Notes
	MHW2-20D	20	0.30N	M5 × 0.8	螺纹类型: -PT: PT螺纹 -NPT: NPT 螺纹 -G: G螺纹
	MHW2-25D	25	0.73N	M5 × 0.8	
	MHW2-32D	32	1.61N	G1/8	Thread Type: -PT: PT Thread -NPT: NPT Thread -G: G Thread
	MHW2-40D	40	3.70N	G1/8	
	MHW2-50D	50	8.27N	G1/4	

MHZ2系列气动手指(平行开闭型气爪) MHZ2 Series Air Gripper (Parallel Open-close Air Claw)

Operating Pressure: 使用压力:0~0.8Mpa 	双动型 Double Acting Type	打开力 Open Force	闭合力 Closing Force	单动常开型 Single Acting Normal Open Type	闭合力 Closing Force	单动常闭型 Single Acting Normal Closed	打开力 Open Force	螺纹接口 Thread Size	标准行程 Standard Stroke	动作频率 Motion Frequency	说明 Notes
	MHZ2-10D	17N	9.8N	MHZ2-10S	6.3N	MHZ2-10S	12N	M3×0.5	4mm	180c.p.m	螺纹类型: -PT: PT 螺纹 -NPT: NPT 螺纹 -G: G 螺纹 Thread Type: -PT: PT Thread -NPT: NPT Thread -G: G Thread
	MHZ2-16D	40N	30N	MHZ2-16S	24N	MHZ2-16S	31N	M5×0.8	6mm	180c.p.m	
	MHZ2-20D	66N	42N	MHZ2-20S	28N	MHZ2-20S	56N	M5×0.8	10mm	180c.p.m	
	MHZ2-25D	104N	65N	MHZ2-25S	45N	MHZ2-25S	83N	M5×0.8	14mm	180c.p.m	
	MHZ2-32D	193N	158N	MHZ2-32S	131N	MHZ2-32S	161N	M5×0.8	22mm	60c.p.m	
MHZ2-40D	318N	254N	MHZ2-40S	137N	MHZ2-40S	267N	M5×0.8	30mm	60c.p.m		

MHZL2系列气动手指(平行开闭型气爪) MHZL2 Series Air Gripper (Parallel Open-close Air Claw)

Operating Pressure: 使用压力:0~0.8Mpa 	双动型 Double Acting Type	单动常开型 Single Normally Open Type	螺纹接口 Port Size	动作频率 Frequency	说明 Notes
	MHZL2-10D	MHC2-10S	M3×0.5	180 c.p.m.	螺纹类型: -PT: PT 螺纹 -NPT: NPT 螺纹 -G: G 螺纹 Thread Type: -PT: PT Thread -NPT: NPT Thread -G: G Thread
	MHZL2-16D	MHC2-16S	M5×0.8	180 c.p.m.	
	MHZL2-20D	MHC2-20S	M5×0.8	180 c.p.m.	
MHZL2-25D	MHC2-25S	M5×0.8	180 c.p.m.		

HFP系列气动手指 HFP Series Air Gripper

Operating Pressure: 使用压力:0~0.8Mpa 	双动型 Double Acting Type	缸径 Bore	接管尺寸 Port Size	说明 Notes
	HFP10	10	M3×0.5	螺纹类型: -PT: PT 螺纹 -NPT: NPT 螺纹 -G: G 螺纹 Thread Type: -PT: PT Thread -NPT: NPT Thread -G: G Thread
	HFP16	16	M5×0.8	
	HFP20	20	M5×0.8	
	HFP25	25	M5×0.8	
HFP32	32	M5×0.8		

HFR系列气动手指 HFR Series Air Gripper

Operating Pressure: 使用压力:0~0.8Mpa 	双动型 Double Acting Type	缸径 Bore	接管尺寸 Port Size	说明 Notes
	HFR10	10	M5×0.8	螺纹类型: -PT: PT 螺纹 -NPT: NPT 螺纹 -G: G 螺纹 Thread Type: -PT: PT Thread -NPT: NPT Thread -G: G Thread
	HFR16	16	M5×0.8	
	HFR20	20	M5×0.8	
	HFR25	25	M5×0.8	
HFR32	32	M5×0.8		

HFY系列气动手指 HFY Series Air Gripper

Operating Pressure: 使用压力:0~0.8Mpa 	双动型 Double Acting Type	缸径 Bore	接管尺寸 Port Size	说明 Notes
	HFY6	6	M3×0.5	螺纹类型: -PT: PT 螺纹 -NPT: NPT 螺纹 -G: G 螺纹 Thread Type: -PT: PT Thread -NPT: NPT Thread -G: G Thread
	HFY10	10	M3×0.5	
	HFY16	16	M5×0.8	
	HFY20	20	M5×0.8	
	HFY25	25	M5×0.8	
HFY32	32	M5×0.8		

HFZ系列气动手指 HFZ Series Air Gripper

Operating Pressure: 使用压力:0~0.8Mpa 	双动型 Double Acting Type	缸径 Bore	闭合力 Close Force	接管尺寸 Port Size	说明 Notes
	HFZ-6	6	3.3N	M3×0.5	螺纹类型: -PT: PT 螺纹 -NPT: NPT 螺纹 -G: G 螺纹 Thread Type: -PT: PT Thread -NPT: NPT Thread -G: G Thread
	HFZ-10	10	11N	M3×0.5	
	HFZ-16	16	34N	M5×0.8	
	HFZ-20	20	45N	M5×0.8	
	HFZ-25	25	69N	M5×0.8	
	HFZ-32	32	160N	M5×0.8	
HFZ-40	40	255N	M5×0.8		

HDM/HDP系列角度型机械爪 HDM/HDP Series Angle Type Mechanical Claw

Operating Pressure: 使用压力:0~0.8Mpa 	双动型 Double Acting Type	双动型 Double Acting Type	缸径 Bore	接管尺寸 Port Size	说明 Notes
	HDM10	HDP10	10	M5×0.8	螺纹类型: -PT: PT螺纹 -NPT: NPT 螺纹 -G: G螺纹 Thread Type: -PT: PT Thread -NPT: NPT Thread -G: G Thread
	HDM16	HDP16	16	M5×0.8	
	HDM20	HDP20	20	M5×0.8	
	HDM25	HDP25	25	M5×0.8	
	HDM32	HDP32	32	M5×0.8	

HDS系列气动手指 HDS Series Angular Gripper

Operating Pressure: 使用压力:0~0.8Mpa 	双动型 Double Acting Type	缸径 Bore	接管尺寸 Port Size	说明 Notes
	HDS10	10	M5×0.8	螺纹类型: -PT: PT螺纹 -NPT: NPT 螺纹 -G: G螺纹 Thread Type: -PT: PT Thread -NPT: NPT Thread -G: G Thread
	HDS16	16	M5×0.8	
	HDS20	20	M5×0.8	
	HDS25	25	M5×0.8	
	HDS32	32	M5×0.8	

TEJ系列气动夹具 TEJ Series Pneumatic Clamp

Operating Pressure: 使用压力:0~0.8Mpa 	型号 Model	缸径 Bore	可选用附件 Available Accessories	派生型号 Derivative Model	说明 Notes
	TEJ16	16	—	—	螺纹类型: -PT: PT螺纹 -NPT: NPT 螺纹 -G: G螺纹 Thread Type: -PT: PT Thread -NPT: NPT Thread -G: G Thread
	TEJ20	20			

MHS系列气爪 MHS Sliding Rail Cylinder

Operating Pressure: 使用压力:0~0.8Mpa 	型号 Model	缸径 Bore Size
	MHS2 MHS3 MHS4	10 50
		20 63
		25 80
		32 100
		40 125

MXJ系列滑台气缸 MXJ Series Slide Cylinder

Operating Pressure: 使用压力:0~0.8Mpa 	型号 Model	缸径 Bore Size
	MXJ4.5	4.5
	MXJ6	6
	MXJ8	8

MXS系列滑台气缸 MXS Series Slide Cylinder

Operating Pressure: 使用压力:0~0.8Mpa 	型号 Model	缸径 Bore Size
	MXS	6
		8
		12
		16
		20

MXH系列滑台气缸 MXH Series Slide Cylinder

Operating Pressure: 使用压力:0~0.8Mpa 	型号 Model	缸径 Bore Size
	MXH	6
		10
		16
		20

MXQ系列滑台气缸 MXQ Series Slide Cylinder

Operating Pressure: 使用压力:0~0.8Mpa 	型号 Model	缸径 Bore Size
	MXQ	6
		8
		10
		16
		20

SCR(L)系列转角气缸 SCR(L) Series Rotary Cylinder

Operating Pressure: 使用压力:0~0.8Mpa 	型号 Model	缸径 Bore Size
	SCR(L)	20
		25
		32
		40
		50
		63

MK/MK2系列旋转气缸 MK/MK2 Series Rotary Cylinder

Operating Pressure: 使用压力:0~0.8Mpa 	型号 Model	型号 Model	缸径 Bore	接管尺寸 Port Size	旋转角度 Rotary Angle	派生型号 Derivative Model	说明 Notes
	MK 16	MK2 16	16	M5	90°	MK/MK2-B:四个安装孔通孔 MK/MK2-A:四个安装孔带螺纹 MK/MK2-R:右转 MK/MK2-L:左转 MK-B: Four Holes Through Hole MK-A: Four Holes With Thread MK-R: Right MK-L: Left	螺纹类型: -PT: PT螺纹 -NPT: NPT 螺纹 -G: G螺纹 Thread Type: -PT: PT Thread -NPT: NPT Thread -G: G Thread
	MK 20	MK2 20	20	M5	90°		
	MK 25	MK2 25	25	M5	90°		
	MK 32	MK2 32	32	PT1/8	90°		
	MK 40	MK2 40	40	PT1/8	90°		
	MK 50	MK2 50	50	PT1/4	90°		
	MK 63	MK2 63	63	PT1/4	90°		

CK1系列夹紧气缸 CK1 Series Clamp Cylinder

Operating Pressure: 使用压力:0~0.8Mpa 	型号 Model	缸径 Bore Size	接管尺寸 Port Size	最大理论出力 Max. Theoretical Force	活塞杆螺纹尺寸 Piston Port Size	派生型号 Derivative Model	说明 Notes
	CK1 40	40	PT1/4	110kgf	20	CK1:基本型(不带磁) CKG1:带磁性 CLKG:带锁带磁性 CK1:Standard(No Magnet) CKG1:With Magnet CLKG-R: Attach Lock & Magnet	螺纹类型: -PT: PT螺纹 -NPT: NPT 螺纹 -G: G螺纹 Thread Type: -PT: PT Thread -NPT: NPT Thread -G: G Thread
	CK1 50	50	PT1/4	170kgf	20		
	CK1 63	63	PT1/4	280kgf	20		
	CK1 80	80	PT3/8	450kgf	25		

CRB1系列大型叶片式摆动气缸 CRB1 Series Large Vane Swing Cylinder

Operating Pressure: 使用压力:0~0.8Mpa 	型号 Model	缸径 Bore	接管尺寸 Port Size	旋转角度 Rotary Angle	派生型号 Derivative Model	说明 Notes
	CRB1 50	50	PT1/8	单叶片:90°、180°、270° 双叶片:90°	CDRB1: 带磁性(With Magnet) 安装形式: CRB1-B:基本型 CRB1-L:脚座型 叶片形式: CRB1-S:单叶片 CRB1-D:双叶片 MoutingType: CRB1-B:Standard CRB1-L:Foot Bracket CRB1-S:Single Vane CRB1-D:Double Vane	螺纹类型: -PT: PT螺纹 -NPT: NPT 螺纹 -G: G螺纹 Thread Type: -PT: PT Thread -NPT: NPT Thread -G: G Thread
	CRB1 63	63	PT1/8			
	CRB1 80	80	PT1/4	Single Vane:90°、180°、270° Double Vane:90°		
	CRB1 100	100	PT1/4			

CRB2BW系列叶片式摆动气缸 CRB2BW Series Vane Swing Cylinder

Operating Pressure: 使用压力:0~0.8Mpa 	型号 Model	缸径 Bore	接管尺寸 Port Size	旋转角度 Rotary Angle	派生型号 Derivative Model	说明 Notes
	CRB2BW 10	10	M3×0.5	单叶片:90°、180°、270° 双叶片:90°、100°	CDRB2: 带磁性(With Magnet) 安装形式: CRB2-B:基本型 CRB2-F:法兰型 叶片形式: CRB2-S:单叶片 CRB2-D:双叶片 MoutingType: CRB2-B:Standard CRB2-F:Flange Bracket CRB2-S:Single Vane CRB2-D:Double Vane	螺纹类型: -PT: PT螺纹 -NPT: NPT 螺纹 -G: G螺纹 Thread Type: -PT: PT Thread -NPT: NPT Thread -G: G Thread
	CRB2BW 15	15	M3×0.5			
	CRB2BW 20	20	M3×0.5	Single Vane:90°、180°、270° Double Vane:90°、100°		
	CRB2BW 30	30	M5×0.8			
	CRB2BW 40	40	M5×0.8			

CRBU2W系列叶片式摆动气缸 CRBU2W Series Vane Swing Cylinder

Operating Pressure: 使用压力:0~0.8Mpa 	型号 Model	缸径 Bore	接管尺寸 Port Size	旋转角度 Rotary Angle	派生型号 Derivative Model	说明 Notes
	CRBU2W 10	10	M3×0.5	单叶片:90°、180°、270° 双叶片:90°、100°	CDRB2: 带磁性(With Magnet) 安装形式: CRBU2-B:基本型 CRBU2-F:法兰型 叶片形式: CRBU2-S:单叶片 CRBU2-D:双叶片 MoutingType: CRBU2-B:Standard CRBU2-F:Flange Bracket CRBU2-S:Single Vane CRBU2-D:Double Vane	螺纹类型: -PT: PT螺纹 -NPT: NPT 螺纹 -G: G螺纹 Thread Type: -PT: PT Thread -NPT: NPT Thread -G: G Thread
	CRBU2W 15	15	M3×0.5			
	CRBU2W 20	20	M5×0.8	Single Vane:90°、180°、270° Double Vane:90°、100°		
	CRBU2W 30	30	M5×0.8			
	CRBU2W 40	40	M5×0.8			

CRA1系列摆动气缸 CRA1 Series Rotary Cylinder

Operating Pressure: 使用压力:0~0.8Mpa 	型号 Model	缸径 Bore	接管尺寸 Port Size	旋转角度 Rotary Angle	最大夹紧力 Max. Cylinder Clamp force	活塞杆直径 Piston OD.	派生型号 Derivative Model	说明 Notes
	CRA1 30	30	M5	90° 180°	1.9N.m	8	CDRA1:带磁性(With Magnet) 安装形式:CRA1-B:基本型 CRA1-L:脚座型 CRA1-F:法兰型 MoutingType: CRA1-B:Standard CRA1-L:Foot Bracket CRA1-F:Flange Bracket	螺纹类型: -PT: PT螺纹 -NPT: NPT 螺纹 -G: G螺纹 Thread Type: -PT: PT Thread -NPT: NPT Thread -G: G Thread
	CRA1 50	50	G1/8	90° 180°	9.3N.m	15		
	CRA1 63	63	G1/8	90° 180°	17N.m	17		
	CRA1 80	80	G1/4	90° 180°	32N.m	20		
	CRA1 100	100	G3/8	90° 180°	74N.m	25		

MSQ系列摆动气缸 MSQ Series Rotary Cylinder

Operating Pressure: 使用压力:0~0.8Mpa 	型号 Model	缸径 Bore	接管尺寸 Port Size	旋转角度 Rotary Angle	派生型号 Derivative Model	说明 Notes
	MSQ10	10	M5×0.8	190°	MSQ-A:高精度型 MSQ-B:基本型 MSQ-A:High-Accuracy Type MSQ-B:Standard Type	螺纹类型: -PT: PT螺纹 -NPT: NPT 螺纹 -G: G螺纹 Thread Type: -PT: PT Thread -NPT: NPT Thread -G: G Thread
	MSQ20	20	M5×0.8	190°		
	MSQ30	30	PT1/8	190°		
	MSQ50	50	PT1/8	190°		
	MSQ70	70	PT1/8	190°		
	MSQ100	100	PT1/8	190°		
	MSQ200	200	PT1/8	190°		

CRQ2系列摆动气缸 CRQ2 Series Rotary Cylinder

Operating Pressure: 使用压力:0~0.8Mpa 	型号 Model	缸径 Bore	接管尺寸 Port Size	旋转角度 Rotary Angle	派生型号 Derivative Model	说明 Notes
	CRQ2-10	10	M5 × 0.8	90°、180°、360°	CRQ2:不带磁 CDRQ2:带磁性	螺纹类型: -PT: PT螺纹 -NPT: NPT 螺纹 -G: G螺纹
	CRQ2-15	15	M5 × 0.8	90°、180°、360°		
	CRQ2-20	20	PT1/8	90°、180°、360°	CRQ2S:No Magnet CDRQ2:With Magnet	Thread Type: -PT: PT Thread -NPT: NPT Thread -G: G Thread
	CRQ2-30	30	PT1/8	90°、180°、360°		
CRQ2-40	40	PT1/8	90°、180°、360°			

MRHQ系列摆台气爪 MRHQ Series Rotary Gripper

Operating Pressure: 使用压力:0~0.8Mpa 	型号 Model	缸径 Bore	接管尺寸 Port Size	旋转角度 Rotary Angle	派生型号 Derivative Model	说明 Notes
	MRHQ10	10	M4 × 0.7	90°、180°	MRHQ-D:双作用 MRHQ-S:单作用(常开) MRHQ-C:单作用(常闭)	螺纹类型: -PT: PT螺纹 -NPT: NPT 螺纹 -G: G螺纹
	MRHQ16	16	M5 × 0.8	90°、180°		
	MRHQ20	20	M6 × 1	90°、180°	MRH1-D:Double Acting MRH1-S:Single Acting(Normally Open) MRH1-C:Single Acting(Normally Closed)	Thread Type: -PT: PT Thread -NPT: NPT Thread -G: G Thread
	MRHQ25	25	M6 × 1	90°、180°		

MSZ系列摆动气缸 MSZ Series Rotary Cylinder

Operating Pressure: 使用压力:0~0.8Mpa 	型号 Model	缸径 Bore	接管尺寸 Port Size	旋转角度 Rotary Angle	派生型号 Derivative Model	说明 Notes
	MSZB10	10	M5 × 0.8	90°	MSZ-A:高精度型 MSZ-B:基本型	螺纹类型: -PT: PT螺纹 -NPT: NPT 螺纹 -G: G螺纹
	MSZB20	20	M5 × 0.8	90°		
	MSZB30	30	M5 × 0.8	90°	MSZ-A:High-Accuracy Type MSZ-B:Standard Type	Thread Type: -PT: PT Thread -NPT: NPT Thread -G: G Thread
	MSZB50	50	M5 × 0.8	90°		

ACK系列旋转气缸 ACK Series Rotary Cylinder

Operating Pressure: 使用压力:0~0.8Mpa 	型号 Model	缸径 Bore	接管尺寸 Port Size	旋转角度 Rotary Angle	派生型号 Derivative Model	说明 Notes
	ACK25	25	M5 × 0.8	90°	ACK:单边压板 ACKD: 双边压板	螺纹类型: -PT: PT螺纹 -NPT: NPT 螺纹 -G: G螺纹
	ACK32	32	PT1/8	90°		
	ACK40	40	PT1/8	90°	ACK:Single Side Arm ACKD: Double Side Arm	Thread Type: -PT: PT Thread -NPT: NPT Thread -G: G Thread
	ACK50	50	PT1/8	90°		
	ACK63	63	PT1/8	90°		

ASC系列全螺纹转角气缸 ASC Series Full Thread Corner Cylinder

Operating Pressure: 使用压力:0~0.8Mpa 	型号 Model	缸径 Bore	接管尺寸 Port Size	旋转角度 Rotary Angle	压板型式 Clamping Arm Type	派生型号 Derivative Model	说明 Notes
	ASC 25	25	M5	90°	-S: 单边压板 -D: 双边压板	回转方向 L:左转 R: 右转	螺纹类型: -PT: PT螺纹 -NPT: NPT 螺纹 -G: G螺纹
	ASC 32	32	PT1/8	90°			
	ASC 40	40	PT1/8	90°	-S:Single Side Arm -D:Double Side Arm	Rotary Direction L: Turn Left R: Turn Right	Thread Type: -PT: PT Thread -NPT: NPT Thread -G: G Thread
	ASC 50	50	PT1/8	90°			
	ASC 63	63	PT1/8	90°			

SRC系列旋转气缸 SRC Series Rotary Cylinder

Operating Pressure: 使用压力:0~0.8Mpa 	型号 Model	缸径 Bore	接管尺寸 Port Size	标准行程 Standard Stroke	旋转角度 Rotary Angle	最大夹紧力 Max Clamp Force	派生型号 Derivative Model	说明 Notes
	SRC25	25	M5	11	90°	200N	R:右转 L:左转 FB: 附带后法兰	螺纹类型: -PT: PT螺纹 -NPT: NPT 螺纹 -G: G螺纹
	SRC32	32	G1/8	13	90°	360N		
	SRC40	40	G1/8	13	90°	630N	R:Turn Right L:Turn Left FB: Attach Rear Flange	Thread Type: -PT: PT Thread -NPT: NPT Thread -G: G Thread
	SRC50	50	G1/8	15	90°	980N		
	SRC63	63	G1/8	15	90°	1680N		

JGL系列杠杆夹持气缸 JGL Series Lever Clamping Cylinder

Operating Pressure: 使用压力:0~0.8Mpa 	型号 Model	缸径 Bore	接管尺寸 Port Size	旋转角度 Rotary Angle	派生型号 Derivative Model	说明 Notes
	JGL25	25	M5 × 0.8	90°	JGL: 基本型 JGLR: 带磁性 JGL: No Magnet JGLR: With Magnet	螺纹类型: -PT: PT螺纹 -NPT: NPT 螺纹 -G: G螺纹 Thread Type: -PT: PT Thread -NPT: NPT Thread -G: G Thread
	JGL32	32	PT1/8	90°		
	JGL40	40	PT1/8	90°		
	JGL50	50	PT1/4	90°		
	JGL63	63	PT1/4	90°		

TWQ系列止动气缸 TWQ Series Stop Cylinder

Operating Pressure: 使用压力:0~0.8Mpa 	型号 Model	缸径 Bore	接管尺寸 Port Size	旋转角度 Rotary Angle	派生型号 Derivative Model	说明 Notes
	TWQ 20	20	M5 × 0.8	90°	TWQ: 复动型 TTQ: 单动引入型	螺纹类型: -PT: PT螺纹 -NPT: NPT 螺纹 -G: G螺纹
	TWQ 25	25	M5 × 0.8	90°		
	TWQ 32	32	PT1/8	90°	TWQ: Double Acting TTQ: Single Acting Spring Push	Thread Type: -PT: PT Thread -NPT: NPT Thread -G: G Thread
	TWQ 40	40	PT1/8	90°		
	TWQ 50	50	PT1/8	90°		

TWH系列止动气缸 TWH Series Stop Cylinder

Operating Pressure: 使用压力:0~0.8Mpa 	型号 Model	缸径 Bore	接管尺寸 Port Size	旋转角度 Rotary Angle	派生型号 Derivative Model	说明 Notes
	TWH 20	20	M5 × 0.8	90°	TWH: 复动型 TDH: 内置弹簧复动型 TTH: 单动引入型	螺纹类型: -PT: PT螺纹 -NPT: NPT 螺纹 -G: G螺纹
	TWH 25	25	M5 × 0.8	90°		
	TWH 32	32	PT1/8	90°	TWH: 复动型 TDW: 内置弹簧复动型 TTM: 单动引入型	Thread Type: -PT: PT Thread -NPT: NPT Thread -G: G Thread
	TWH 40	40	PT1/8	90°		
	TWH 50	50	PT1/8	90°	TWH: Double Acting Type TDH: Built-In Spring Double Acting Type TTH: Single Acting-Pull Type TWM: Double Acting Type TDM: Built-In Spring Double Acting Type TTM: Single Acting-Pull Type	Thread Type: -PT: PT Thread -NPT: NPT Thread -G: G Thread
	TWH 63	63	PT1/4	90°		
	TWH 80	80	PT1/4	90°		

TWG系列止动气缸 TWG Series Stop Cylinder

Operating Pressure: 使用压力:0~0.8Mpa 	型号 Model	缸径 Bore	接管尺寸 Port Size	旋转角度 Rotary Angle	派生型号 Derivative Model	说明 Notes
	TWG 32	32	PT1/8	90°	TWG: 高度可调复动型 TTG: 高度可调单动引入型	螺纹类型: -PT: PT螺纹 -NPT: NPT 螺纹 -G: G螺纹
	TWG 40	40	PT1/8	90°		
	TWG 50	50	PT1/8	90°	TWG: Double Acting Type (Adjustable for Height) TTG: Single Acting Pull Type (Adjustable for Height)	Thread Type: -PT: PT Thread -NPT: NPT Thread -G: G Thread

RTP系列摆动气缸 RTP Series Rotary Cylinder

Operating Pressure: 使用压力:0~0.8Mpa 	型号 Model	缸径 Bore	接管尺寸 Port Size	旋转角度 Rotary Angle	派生型号 Derivative Model	说明 Notes
	RTP 5	5	PT1/8	90° & 180°	主轴型式: -空白: 单轴 -2D: 双轴	螺纹类型: -PT: PT螺纹 -NPT: NPT 螺纹 -G: G螺纹 Thread Type: -PT: PT Thread -NPT: NPT Thread -G: G Thread
	RTP 10	10	PT1/8			
	RTP 20	20	PT1/8		Axis Type: -Blank: Single Rod -2D: Double Rod	
	RTP 30	30	PT1/8			

RTH系列摆动气缸 RTH Series Rotary Cylinder

Operating Pressure: 使用压力:0~0.8Mpa 	型号 Model	缸径 Bore	接管尺寸 Port Size	旋转角度 Rotary Angle	派生型号 Derivative Model	说明 Notes
	RTH 40	40	PT1/4	90° & 180°	主轴型式: -空白: 单轴 -F: 内孔型 -2D: 双轴	螺纹类型: -PT: PT螺纹 -NPT: NPT 螺纹 -G: G螺纹 Thread Type: -PT: PT Thread -NPT: NPT Thread -G: G Thread
	RTH 63	63	PT3/8			
	RTH 80	80	PT3/8		Rod Type: -Blank: Single Rod -F: Inner Hole Type -2D: Double Rods	

ZH系列气液转换器 ZH Series Air-Liquid Converter

Operating Pressure: 使用压力:0~0.8Mpa 	型号 Model	缸径 Bore	接管尺寸 Port Size	可选用附件 Available Accessories	派生型号 Derivative Model	说明 Notes
	ZH32	32	G1/8	FA-前法兰 FB-后法兰 LB-双脚架 FA-Front Flange FB-Rear Flange LB-Foot Bracket	—	螺纹类型: -PT: PT螺纹 -NPT: NPT 螺纹 -G: G螺纹 Thread Type: -PT: PT Thread -NPT: NPT Thread -G: G Thread
	ZH40	40	G1/4			
	ZH50	50	G1/4			
	ZH63	63	G3/8			
	ZH80	80	G3/8			
	ZH100	100	G1/2			
	ZH125	125	G1/2			

QGZN系列气液阻尼缸 QGZN Series Air-Liquid Damping Cylinder

Operating Pressure: 使用压力:0~0.8Mpa 	型号 Model	缸径 Bore	接管尺寸 Port Size	活塞杆螺纹尺寸 Piston Port Size	可选用附件 Available Accessories	派生型号 Derivative Model	说明 Notes
	QGZN32	32	G1/8	M10 × 1.25	FA-前法兰 FB-后法兰 CA-单尾耳 CB-双尾耳 LB-双脚架 Y-Y接头 I-I接头 TC-中间滚轴 FA-Front Flange FB-Rear Flange CA-Single Clevis CB-Double Clevis LB-Foot Bracket Y-Y Joint I-I Joint TC-Centertrunnion	—	螺纹类型: -PT: PT螺纹 -NPT: NPT 螺纹 -G: G螺纹 Thread Type: -PT: PT Thread -NPT: NPT Thread -G: G Thread
	QGZN40	40	G1/4	M12 × 1.25			
	QGZN50	50	G1/4	M16 × 1.5			
	QGZN63	63	G3/8	M16 × 1.5			
	QGZN80	80	G3/8	M20 × 1.5			
	QGZN100	100	G1/2	M20 × 1.5			
	QGZN125	125	G1/2	M27 × 2			

PM系列打刀气缸 PM Series Strike Knife Cylinder

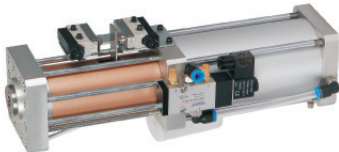
Operating Pressure: 使用压力:0~0.8Mpa 	型号 Model	缸径 Bore	接管尺寸 Port Size	派生型号 Derivative Model	说明 Notes
	PM-3.5T	63	PT3/8	接电方式: 空白:DIN插电式 I:出线式 Power Connection Type: Blank: DIN Plug-In I: Wire Type	螺纹类型: -PT: PT螺纹 -NPT: NPT 螺纹 -G: G螺纹 Thread Type: -PT: PT Thread -NPT: NPT Thread -G: G Thread
	PM-4.5T	63	PT3/8		
	PM-6.0T	70	PT3/8		

MPT/MPTF/MPTS系列气液增压缸 MPT/MPTF/MPTS Series Air-Liquid Boosting Cylinder

Operating Pressure: 使用压力:0~0.8Mpa 	型号 Model	缸径 Bore	接管尺寸 Port Size	活塞杆螺纹尺寸 Piston Port Size	工作频率 Working Frequency	操作速度 Operating Speed	派生型号 Derivative Model	说明 Notes
	MPT-1T	63	PT1/4	M26 × 1.5	20-30次/分钟 20-30 Times/Min	50-700mm/s	MPT:标准型 MPTF:快速型 MPTS:油槽内置型 MPT: Standard Type MPTF: High Speed Type MPTS: Built-in Oil Groove Type	螺纹类型: -PT: PT螺纹 -NPT: NPT 螺纹 -G: G螺纹 Thread Type: -PT: PT Thread -NPT: NPT Thread -G: G Thread
	MPT-3T	63	PT3/8	M30 × 1.5				
	MPT-5T	80	PT3/8	M30 × 1.5	10次/分钟 10 Times/Min			
	MPT-10T	100	PT3/8	M40 × 2				
	MPT-13T	100	PT3/8	M40 × 2				
	MPT-15T	125	PT3/8	M50 × 2				
	MPT-20T	125	PT3/8	M50 × 2				
	MPT-30T	150	PT1/2	M63 × 2				
	MPT-40T	160	PT1/2	M63 × 2				

MPTC/MPTD系列气液增压缸 MPTC/MPTD Series Air-Liquid Boosting Cylinder

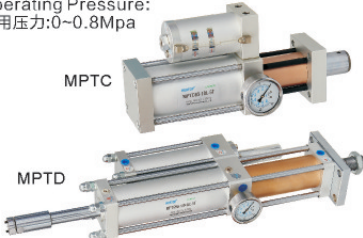
Operating Pressure: 使用压力:0~0.8Mpa 	型号 Model	缸径 Bore	接管尺寸 Port Size	活塞杆螺纹尺寸 Piston Port Size	工作频率 Working Frequency	操作速度 Operating Speed	派生型号 Derivative Model	说明 Notes
	MPTC-1T	50	G1/4	M16 × 2	20次/分钟 20 Times/Min	50-700mm/s	MPTC:直压式 MPTD:全行程可调 MPTC: Direct Pressure Type MPTD: Stroke Adjustable Type	螺纹类型: -PT: PT螺纹 -NPT: NPT 螺纹 -G: G螺纹 Thread Type: -PT: PT Thread -NPT: NPT Thread -G: G Thread
	MPTC-2T	50	G1/4	M16 × 2				
	MPTC-3T	63	G1/4	M16 × 2				
	MPTC-5T	63	G1/4	M16 × 2				
	MPTC-8T	80	G3/8	M16 × 2				
	MPTC-13T	80	G1/2	M20 × 2.5				

BF系列低摩擦气缸 BF Series Lower Friction Cylinder

Operating Pressure: 使用压力:0~0.8Mpa 	型号 Model	缸径 Bore	接管尺寸 Port Size	活塞杆直径 Piston OD	可选用附件 Available Accessories	轴承类型 Bearing Type	说明 Notes
	BF40	40	PT1/8	M10 × 1.25	FA-前法兰 FB-后法兰 CA-单悬耳 CB-双悬耳 LB-双脚架 Y-Y接头 TC-中间摆轴 I-I接头	空白:干性轴承 B1:线性轴承(无密封件) B2:线性轴承(两侧带密封件)	螺纹类型: -PT: PT 螺纹 -NPT: NPT 螺纹 -G: G 螺纹
	BF50	50	PT1/8	M10 × 1.25			
	BF63	63	PT1/4	M12 × 1.5			
	BF80	80	PT1/4	M16 × 1.5			
	BF100	100	PT1/4	M20 × 1.5	FA-Front Flange FB-Rear Flange CA-Single Clevis CB-Double Clevis LB-Foot Bracket Y-Y Joint I-I Joint TC-Center Trunnion	Blank: Dry Bearing B1: Linear Ball Bearing (With Seal) B2: Linear Ball Bearing (Without Seal)	Thread Type: -PT: PT Thread -NPT: NPT Thread -G: G Thread
	BF112	112	PT3/8	M22 × 1.5			
	BF125	125	PT3/8	M24 × 1.5			
BF140	140	PT3/8	M27 × 1.5				

HTCS系列低摩擦气缸 HTCS Series Lower Friction Cylinder

Operating Pressure: 使用压力:0~0.8Mpa 	型号 Model	缸径 Bore	接管尺寸 Port Size	活塞杆直径 Piston OD	可选用附件 Available Accessories	轴承类型 Bearing Type	说明 Notes
	HTCS40	40	PT1/8	M10 × 1.25	FA-前法兰 FB-后法兰 CA-单悬耳 CB-双悬耳 LB-双脚架 Y-Y接头 TC-中间摆轴 I-I接头	空白:干性轴承 B1:线性轴承(无密封件) B2:线性轴承(两侧带密封件)	螺纹类型: -PT: PT 螺纹 -NPT: NPT 螺纹 -G: G 螺纹
	HTCS50	50	PT1/8	M10 × 1.25			
	HTCS63	63	PT1/4	M12 × 1.5			
	HTCS80	80	PT1/4	M16 × 1.5			
	HTCS100	100	PT1/4	M20 × 1.5	FA-Front Flange FB-Rear Flange CA-Single Clevis CB-Double Clevis LB-Foot Bracket Y-Y Joint I-I Joint TC-Center Trunnion	Blank: Dry Bearing B1: Linear Ball Bearing (With Seal) B2: Linear Ball Bearing (Without Seal)	Thread Type: -PT: PT Thread -NPT: NPT Thread -G: G Thread
	HTCS112	112	PT3/8	M22 × 1.5			
	HTCS125	125	PT3/8	M24 × 1.5			
HTCS140	140	PT3/8	M27 × 1.5				

HTCC系列低摩擦比例气缸 HTCC Series Lower Friction Proportional Cylinder

Operating Pressure: 使用压力:0~0.8Mpa 	型号 Model	缸径 Bore	接管尺寸 Port Size	活塞杆直径 Piston OD	可选用附件 Available Accessories	轴承类型 Bearing Type	说明 Notes
	HTCC40	40	PT1/8	M10 × 1.25	FA-前法兰 FB-后法兰 CA-单悬耳 CB-双悬耳 LB-双脚架 Y-Y接头 TC-中间摆轴 I-I接头	空白:干性轴承 B1:线性轴承(无密封件) B2:线性轴承(两侧带密封件)	螺纹类型: -PT: PT 螺纹 -NPT: NPT 螺纹 -G: G 螺纹
	HTCC50	50	PT1/8	M10 × 1.25			
	HTCC63	63	PT1/4	M12 × 1.5			
	HTCC80	80	PT1/4	M16 × 1.5			
	HTCC100	100	PT1/4	M20 × 1.5	FA-Front Flange FB-Rear Flange CA-Single Clevis CB-Double Clevis LB-Foot Bracket Y-Y Joint I-I Joint TC-Center Trunnion	Blank: Dry Bearing B1: Linear Ball Bearing (With Seal) B2: Linear Ball Bearing (Without Seal)	Thread Type: -PT: PT Thread -NPT: NPT Thread -G: G Thread
	HTCC112	112	PT3/8	M22 × 1.5			
	HTCC125	125	PT3/8	M24 × 1.5			
HTCC140	140	PT3/8	M27 × 1.5				

ZQ系列拖链 ZQ Series Cable Track Towing Chain 	型号 Model
	ZQ56 × 95D
	ZQ56 × 125D
	ZQ56 × 150D
	ZQ56 × 175D
	ZQ56 × 200D
	ZQ56 × 225D
	ZQ56 × 250D

HGH系列直线导轨 HGH Series Linear Guides 	型号 Model
	HGH15CA
	HGH20CA
	HGH30CA
	HGH35CA
	HGH45CA
	HGH55CA
	HGH65CA

OST/OSP系列机械式无杆气缸 OST/OSP Series Rodless Cylinder 	型号 Model
	OSP-10
	OSP-16
	OSP-25
	OSP-32
	OSP-40
	OSP-50
	OSP-63
OSP-80	

HTA系列伺服电缸 HTA Series Servo Electric Cylinder 	型号 Model
	HTA-16
	HTA-25
	HTA-40
	HTA-50
	HTA-63
	HTA-80
	HTA-100

HTB系列伺服电缸 HTB Series Servo Electric Cylinder 	型号 Model
	HTB-16
	HTB-25
	HTB-40
	HTB-50
	HTB-63
	HTB-80
	HTB-100

HTC系列伺服电缸 HTC Series Servo Electric Cylinder 	型号 Model
	HTC-16
	HTC-25
	HTC-40
	HTC-50
	HTC-63
	HTC-80
	HTC-100

气动压力机 Air Press

HT-1A系列单柱台式机压力机 HT-1A Series Single Column Air Press	型号 Model
	HT-1A-63
	HT-1A-63A
	HT-1A-80
	HT-1A-100
	HT-1A-125
	HT-1A-160

HT-2A系列双柱台式机压力机 HT-2A Series Double Column Air Press	型号 Model
	HT-2A-63
	HT-2A-63A
	HT-2A-80
	HT-2A-100
	HT-2A-125
	HT-2A-160

HT-2B系列双柱型转盘式压力机 HT-2B Series Double Column Air Press	型号 Model
	HT-2B-63
	HT-2B-80
	HT-2B-100
	HT-2B-125
	HT-2B-160

HT-4A系列四柱气缸型高精压力机 HT-4A Series Quadruple Column High Accuracy Air Press	型号 Model
	HT-4A-63
	HT-4A-80
	HT-4A-100
	HT-4A-125
	HT-4A-160

HT-4B型四柱高精气液增压机 HT-4B Quadruple Column High Accuracy Boosting Press	型号 Model
	HT-4B-63
	HT-4B-80
	HT-4B-100
	HT-4B-125
	HT-4B-150

HT-4C型四柱三板气缸高精压力机 HT-4C Triple Column High Accuracy Air Press	型号 Model
	HT-4C-63
	HT-4C-80
	HT-4C-100
	HT-4C-125
	HT-4C-160

HT-4D型四柱三板气液增压机 HT-4D Triple Column High Accuracy Boosting Press	型号 Model
	HT-4D-63
	HT-4D-80
	HT-4D-100
	HT-4D-125
	HT-4D-150

HTC-1-63系列半弓台式气动压力机 HTC-1-63 Series Column Air Press	型号 Model
	HTC-1-63
	HTC-1-80
	HTC-1-100
	HTC-1-125
	HTC-1-160

HTC-2-63系列半弓台式气动压力机 HTC-2-63 Series Column Air Press	型号 Model
	HTC-2-63
	HTC-2-80
	HTC-2-100
	HTC-2-125
	HTC-2-160

密封圈 Seals



SC系列气缸附件 SC Series Cylinder Accessories

产品图片 Product Photo								
型号 Model	CA	CB	FA	LB	TC	TCM1	Y+PIN	I
材质 Material	铸钢 Cast Steel	铸钢 Cast Steel	32-100:铝合金 Aluminium alloy 125-200:碳钢 Carbon Steel	碳钢 Carbon Steel	铸钢 Cast Steel	铸钢 Cast Steel	铸铁 :Cast Iron	铸铁 :Cast Iron

SI/SAI系列气缸附件 SI/SAI Series Cylinder Accessories

产品图片 Product Photo						
型号 Model	CA	RB	CB	CR	FA	LB
材质 Material	32-125:精铸钢 160-200:球墨铸铁 32-125:Cast Steel 160-200:Nodular Cast Iron	32-100:铝合金 32-100:Aluminium Alloy	32-125:精铸钢 160-200:球墨铸铁 32-125:Cast Steel 160-200:Nodular Cast Iron	铸钢 Cast Steel	32-100:铝合金 Aluminium alloy 160-320:碳钢 Carbon Steel	碳钢 Carbon Steel

产品图片 Product Photo						
型号 Model	FTC/ZNCF	TC/DAMT	TCM1/HZNG	TCM2/LZNG	Y+PINY	I
材质 Material	碳钢 Carbon Steel	碳钢 Carbon Steel	碳钢 Carbon Steel	铝合金 Aluminium alloy	碳钢 Carbon Steel	碳钢 Carbon Steel

DSBC/DSBG/DNC系列气缸附件 DSBC/DSBG/DNC Series Cylinder Accessories

产品图片 Product Photo						
型号 Model	CA/SNCL	CS/SNCS	CB/SNCB	CR/LNG	FA/FNC	LB/HNC
材质 Material	32-125:铝合金 160-320:球墨铸铁 32-125:Aluminium Alloy 160-320:Nodular Cast Iron	32-125:铝合金 160-320:球墨铸铁 32-125:Aluminium Alloy 160-320:Nodular Cast Iron	32-125:铝合金 160-320:球墨铸铁 32-125:Aluminium Alloy 160-320:Nodular Cast Iron	32-125:铝合金 160-320:球墨铸铁 32-125:Aluminium Alloy 160-320:Nodular Cast Iron	碳钢 Carbon Steel	碳钢 Carbon Steel

产品图片 Product Photo						
型号 Model	FTC/ZNCF	TC/DAMT	TCM1/HZNG	TCM2/LZNG	Y+PIN Y	I
材质 Material	碳钢 Carbon Steel	碳钢 Carbon Steel	碳钢 Carbon Steel	铝合金 Aluminium Alloy	碳钢 Carbon Steel	碳钢 Carbon Steel

MBB系列气缸附件 MBB Series Cylinder Accessories

产品图片 Product Photo									
型号 Model	CA/C	CB/D	CR/B	FA/F	LB/L	TC/T	TCM/S	Y	I
材质 Material	球墨铸铁 Nodular Cast Iron	球墨铸铁 Nodular Cast Iron	球墨铸铁 Nodular Cast Iron	球墨铸铁 Nodular Cast Iron	碳钢 Carbon Steel	碳钢 Carbon Steel	球墨铸铁 Nodular Cast Iron	球墨铸铁 Nodular Cast Iron	碳钢 Carbon Steel

CA2BN系列气缸附件 CA2BN Series Cylinder Accessories

产品图片 Product Photo									
型号 Model	CA/C	CB/D	CR/B	FA/F	LB/L	TC/T	TCM/S	Y	I
材质 Material	球墨铸铁 Nodular Cast Iron	球墨铸铁 Nodular Cast Iron	球墨铸铁 Nodular Cast Iron	球墨铸铁 Nodular Cast Iron	碳钢 Carbon Steel	碳钢 Carbon Steel	球墨铸铁 Nodular Cast Iron	球墨铸铁 Nodular Cast Iron	碳钢 Carbon Steel

CS2BN/CS1BN系列气缸附件 CS2BN/CS1BN Series Cylinder Accessories

产品图片 Product Photo							
型号 Model	CA/C	CB/D	FA/F	LB/L	TC/T	Y	I
材质 Material	125-160:碳钢 180-300:铸铁 125-160:Carbon Steel 180-300:Cast Iron	125-160:碳钢 180-300:铸铁 125-160:Carbon Steel 180-300::Cast Iron	碳钢 Carbon Steel	碳钢 Carbon Steel	碳钢 Carbon Steel	125-160:碳钢 180-300:铸铁 125-160:Carbon Steel 180-300::Cast Iron	125-160:碳钢 180-300:铸铁 125-160:Carbon Steel 180-300::Cast Iron





CG1BN/MG系列气缸附件 CG1BN/MG Series Cylinder Accessories

产品图片 Product Photo								
型号 Model	LB/L	FA/F	CB/D	U/T	24A	TCM/S	Y	I
材质 Material	碳钢 Carbon Steel	碳钢 Carbon Steel	铸钢 Cast Steel	铸钢 Cast Steel	碳钢 Carbon Steel	碳钢 Carbon Steel	碳钢 Carbon Steel	碳钢 Carbon Steel



DSNU/C85/MI系列气缸附件 DSNU/C85/MI Series Cylinder Accessories

产品图片 Product Photo						
型号 Model	FBN/FA/F/G	TC/U/T	LB/L	SDB/E-B	Y+PIN	I
材质 Material	碳钢 Carbon Steel	铸钢 Cast Steel	碳钢 Carbon Steel	碳钢 Carbon Steel	碳钢 Carbon Steel	碳钢 Carbon Steel

CQ2B/ACQ/SDA系列气缸附件 CQ2B/ACQ/SDA Series Cylinder Accessories

产品图片 Product Photo				
型号 Model	FA/F/G	CA/C	CB/D	LB/L
材质 Material	碳钢 Carbon Steel	碳钢 Carbon Steel	碳钢 Carbon Steel	碳钢 Carbon Steel

ADVU/ACP系列气缸附件 ADVU/ACP Series Cylinder Accessories

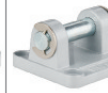
产品图片 Product Photo				
型号 Model	FA/F/G	CA/C	CB/D	LB/L
材质 Material	碳钢 Carbon Steel	铝合金 Aluminium alloy	铸钢 Cast Steel	碳钢 Carbon Steel

CDJ2B/CDM2B/MF/PB系列气缸附件 CDJ2B/CDM2B/MF/PB Series Cylinder Accessories

产品图片 Product Photo								
型号 Model	FA/F/G	CA/C	CB/D	TC/U/T	LB/L	SDB/E-B	Y	I
材质 Material	碳钢 Carbon Steel	碳钢 Carbon Steel	碳钢 Carbon Steel	铸钢 Cast Steel	碳钢 Carbon Steel	碳钢 Carbon Steel	碳钢 Carbon Steel	碳钢 Carbon Steel

MA/MAL系列气缸附件 MAMAL Series Cylinder Accessories

产品图片 Product Photo			
型号 Model	LB	FA/FB	SDB
材质 Material	碳钢 Carbon Steel	碳钢 Carbon Steel	碳钢 Carbon Steel

MO、HO系列油缸附件 MO、HO Series Cylinder Accessories

产品图片 Product Photo					
型号 Model	FA	Y	CB	TC	CA
材质 Material	铸钢 Cast Steel	铸钢 Cast Steel	铸钢 Cast Steel	铸钢 Cast Steel	铸钢 Cast Steel

FJ-10系列浮动接头 FJ-10 Series Floating Joint

	型号 Model	规格 Specification	型号 Model	规格 Specification	型号 Model	规格 Specification
	FJ-1003	M3 × 0.5	FJ-1010	M10 × 1.5	FJ-1022	M22 × 1.5
	FJ-1004	M4 × 0.7	FJ-1012	M12 × 1.25	FJ-1026	M26 × 1.5
	FJ-1005	M5 × 0.8	FJ-1014	M14 × 1.5	FJ-1027	M27 × 2
	FJ-1006	M6 × 1.0	FJ-1016	M16 × 1.5	FJ-1036	M36 × 2
	FJ-1008	M8 × 1.25	FJ-1018	M18 × 1.5		
	FJ-1010	M10 × 1.25	FJ-1020	M20 × 1.5		

FJ-11系列鱼眼接头 FJ-11 Series Fish Eye Joint

	型号 Model	规格 Specification	型号 Model	规格 Specification	型号 Model	规格 Specification
	FJ-1105	M5 × 0.8	FJ-1110	M10 × 1.25	FJ-1116	M16 × 1.5
	FJ-1106	M6 × 1.0	FJ-1112	M12 × 1.25	FJ-1118	M18 × 1.5
	FJ-1108	M8 × 1.25	FJ-1114	M14 × 1.5	FJ-1120	M20 × 1.5

CS1系列磁簧管式磁性开关 CS1 Series Magnetic Reed Switch

型号 Model	适用气缸型号 Applicable Cylinder Models
CS1-A	SC/SCL
CS1-E	SE/ACE
CS1-F	SI/SIL/SU/SUL/JSI/SC/SCL/MI
CS1-G	ACP/ACQ/TACQ/SDA/TWQ/TWH/TWM/MD/MK/TR/TCL/TCM/STW/QCK/HFZ/HFY/HFP
CS1-J	ACQ/TACQ/SDA/TWQ/TWH/TWM/TN/QCK
CS1-M	MG/MA/MAC/MI/PB/PBR/MF/MAL
CS1-T	TWG
CS1-U	SI/SIL/SU/SUL/JSI/SC/SCL/MI

DS1系列电子式磁性开关 DS1 Series Magnetic Solid State Switch

型号 Model	适用气缸型号 Applicable Cylinder Models
DS1-A	SC/SCL
DS1-E	SE/ACE
DS1-F	SI/SIL/SU/SUL/JSI/SC/SCL/MI
DS1-G	ACP/ACQ/TACQ/SDA/TWQ/TWH/TWM/MD/MK/TR/TCL/TCM/STW/QCK/HFZ/HFY/HFP
DS1-H	ACQ/TACQ/SDA/TWQ/TWH/TWM/TN/QCK
DS1-J	ACQ/TACQ/HFZ/HFP/HFR/HLQ/HLS/MU/HLH/MGP/HRQ
DS1-M	MG/MA/MAC/MI/PB/PBR/MF/MAL
DS1-T	TWG
DS1-U	SI/SIL/SU/SUL/JSI/SC/SCL/MI

CMS系列磁性开关 CMS Series Magnetic Switch

型号 Model	适用气缸型号 Applicable Cylinder Models
CMSE	SE/BSE/SAI/ACE
DMSE	
CMSG	ACP/ACQ/TACQ/SDA/TWQ/TCL/TCM/QCK/TWH/TWM/SAU/HFZ/HFY/HFP/MD/MK/AQK/BAQK/TR/STW/HFK/HFKP/PB/MI/MF/MG/MA/MAL/MCK/SC
DMSG	
CMSH	ACQ/TACQ/HFZ/HFY/HFP/HFR/HFC/HFT/QDK/HLQ/HLS/MU/HLH/MPG/HRQ/HFK/HLF/HGS/RMH/HFD/HFKP/HFKL/HFCQ
DMSH(S)	
CMSJ	ACQ/SDA/TWQ/QCK/QDK/TN/TWH/TWM
DMSJ(S)	

SME/SMT/SDBT/CRSMT系列磁性开关 SME/SMT/SDBT/CRSMT Series Magnetic Switch

型号 Model	型号 Model
SME-8-ZS-KL-LED	SMT-8M-A
SME-8K-LED	SMT-8G
SME-8M-ZS-24V-K	SMT-8-SL
SME-8M-DS-24V-K	SDBT-BSW
SME-8M-DS-24V-K-0.3-M8D	CRSMT-8M

D系列磁性开关 D Series Magnetic Switch

型号 Model	适用气缸型号 Applicable Cylinder Models
D-A73	CDQ2B16-25/CQ2B32-200
D-A93	CQ2B/CU/MGPM/CXSJM/MHZ/MHY/MHS
D-C73	CG1BN/CM2B/C85
D-Z73	CXSM/CXSW/MGPM
D-M9B	CDJ2B/CDM2B/CG1BN/MB/CA2/C55/CP96
D-M9N	CDJ2B/CDM2B/CG1BN/MB/CA2/C55/CP96
D-M9P	CDJ2B/CDM2B/CG1BN/MB/CA2/C55/CP96

磁性开关安装支架 Magnetic Switch Mounting Bracket

型号 Model	适用气缸型号 Applicable Cylinder Models
TS-11	拉杆式缸径32-100万能式 Universal Type for Tie Rod Bore Size:32-100
TS-12	拉杆式缸径32-100万能式 Universal Type for Tie Rod Bore Size:32-100
TS-13	拉杆式缸径32-100 Tie-Rod Type Bore Size:32-100
TS-14	拉杆式缸径100/125 Tie-Rod Type Bore Size:100/125
TS-15	拉杆式缸径160 Tie-Rod Type Bore Size:160
TS-17	F万能扎带 方型孔 F Type Universal Bracket(Flat Hole)
TS-18	S万能扎带 方型孔 S Type Universal Bracket(Flat Hole)
TS-19	F万能扎带 圆型孔 F Type Universal Bracket(Round Hole)

DNC气缸套件 DNC Cylinder Kits	型号 Model
	Φ32
	Φ40
	Φ50
	Φ63
	Φ80
	Φ100
	Φ125

SI气缸套件 SI Cylinder Kits	型号 Model
	Φ32
	Φ40
	Φ50
	Φ63
	Φ80
	Φ100
	Φ125

SC气缸套件 SC Cylinder Kits	型号 Model
	Φ32
	Φ40
	Φ50
	Φ63
	Φ80
	Φ100
	Φ125

DNC方形管 DNC Square Aluminum Tube	型号 Model
	Φ32
	Φ40
	Φ50
	Φ63
	Φ80
	Φ100
	Φ125

SI米字形管 SI Cylinder Aluminum Tube	型号 Model
	Φ32
	Φ40
	Φ50
	Φ63
	Φ80
	Φ100
	Φ125

活塞杆 Piston Rod	型号 Model	
	Φ6	Φ32
	Φ8	Φ40
	Φ10	Φ45
	Φ12	Φ50
	Φ16	Φ60
	Φ20	Φ70
	Φ25	Φ80

公制微型快插接头 Meter Type Mini One Touch Fitting

PC	4	-	M3	C
系列号 Series	管外径 Tube OD.		螺纹 Thread	微型 Mini Type

英制微型快插接头 Inch Type Mini One Touch Fitting

PC	5/32	-	NPT01	C
系列号 Series	管外径 Tube OD.		螺纹 Thread	微型 Mini Type

技术参数 Specification

主要材质 Main Material	铜、塑料 Brass, Plastic
最高耐压力 Proof Pressure	1.32Mpa
使用压力范围 Pressure Range	0~0.9Mpa
环境及流体温度 Ambient & Fluid Temp.	0~60°C
可配插管类别 Applicable Tube Type	PU软管、PE软管等 PU Tube, PE Tube, etc.
可配插管尺寸 Applicable Tube Size	公制插管、英制插管 Meter Tube, Inch Tube
可配螺纹 Applicable Thread	M、G、PT、NPT、UNI、UNF螺纹等 M、G、PT、NPT、UNI、UNF Thread, etc.

PC-C  <table border="1"> <tr><th colspan="2">管外径 × 螺纹 Tube OD. × Thread Size</th></tr> <tr><td>3-M3</td><td>5-M5</td></tr> <tr><td>3-M5</td><td>5-01</td></tr> <tr><td>3-01</td><td>5-02</td></tr> <tr><td>4-M5</td><td>6-M5</td></tr> <tr><td>4-01</td><td>6-01</td></tr> <tr><td>4-02</td><td>6-02</td></tr> </table>	管外径 × 螺纹 Tube OD. × Thread Size		3-M3	5-M5	3-M5	5-01	3-01	5-02	4-M5	6-M5	4-01	6-01	4-02	6-02	POC-C  <table border="1"> <tr><th colspan="2">管外径 × 螺纹 Tube OD. × Thread Size</th></tr> <tr><td>3-M3</td><td>5-M5</td></tr> <tr><td>3-M5</td><td>5-01</td></tr> <tr><td>3-01</td><td>5-02</td></tr> <tr><td>4-M5</td><td>6-M5</td></tr> <tr><td>4-01</td><td>6-01</td></tr> <tr><td>4-02</td><td>6-02</td></tr> </table>	管外径 × 螺纹 Tube OD. × Thread Size		3-M3	5-M5	3-M5	5-01	3-01	5-02	4-M5	6-M5	4-01	6-01	4-02	6-02	PL-C  <table border="1"> <tr><th colspan="2">管外径 × 螺纹 Tube OD. × Thread Size</th></tr> <tr><td>3-M3</td><td>5-M5</td></tr> <tr><td>3-M5</td><td>5-01</td></tr> <tr><td>3-01</td><td>5-02</td></tr> <tr><td>4-M5</td><td>6-M5</td></tr> <tr><td>4-01</td><td>6-01</td></tr> <tr><td>4-02</td><td>6-02</td></tr> </table>	管外径 × 螺纹 Tube OD. × Thread Size		3-M3	5-M5	3-M5	5-01	3-01	5-02	4-M5	6-M5	4-01	6-01	4-02	6-02	PB-C  <table border="1"> <tr><th colspan="2">管外径 × 螺纹 Tube OD. × Thread Size</th></tr> <tr><td>3-M5</td><td></td></tr> <tr><td>4-M5</td><td></td></tr> <tr><td>5-M5</td><td></td></tr> <tr><td>6-M5</td><td></td></tr> </table>	管外径 × 螺纹 Tube OD. × Thread Size		3-M5		4-M5		5-M5		6-M5	
管外径 × 螺纹 Tube OD. × Thread Size																																																							
3-M3	5-M5																																																						
3-M5	5-01																																																						
3-01	5-02																																																						
4-M5	6-M5																																																						
4-01	6-01																																																						
4-02	6-02																																																						
管外径 × 螺纹 Tube OD. × Thread Size																																																							
3-M3	5-M5																																																						
3-M5	5-01																																																						
3-01	5-02																																																						
4-M5	6-M5																																																						
4-01	6-01																																																						
4-02	6-02																																																						
管外径 × 螺纹 Tube OD. × Thread Size																																																							
3-M3	5-M5																																																						
3-M5	5-01																																																						
3-01	5-02																																																						
4-M5	6-M5																																																						
4-01	6-01																																																						
4-02	6-02																																																						
管外径 × 螺纹 Tube OD. × Thread Size																																																							
3-M5																																																							
4-M5																																																							
5-M5																																																							
6-M5																																																							
PD-C  <table border="1"> <tr><th colspan="2">管外径 × 螺纹 Tube OD. × Thread Size</th></tr> <tr><td>3-M5</td><td></td></tr> <tr><td>4-M5</td><td></td></tr> <tr><td>5-M5</td><td></td></tr> <tr><td>6-M5</td><td></td></tr> </table>	管外径 × 螺纹 Tube OD. × Thread Size		3-M5		4-M5		5-M5		6-M5		PU-C  <table border="1"> <tr><th colspan="2">管外径 × 管外径 Tube OD. × Tube OD.</th></tr> <tr><td>-3</td><td></td></tr> <tr><td>-4</td><td></td></tr> <tr><td>-5</td><td></td></tr> <tr><td>-6</td><td></td></tr> </table>	管外径 × 管外径 Tube OD. × Tube OD.		-3		-4		-5		-6		PV-C  <table border="1"> <tr><th colspan="2">管外径 × 管外径 Tube OD. × Tube OD.</th></tr> <tr><td>-3</td><td></td></tr> <tr><td>-4</td><td></td></tr> <tr><td>-5</td><td></td></tr> <tr><td>-6</td><td></td></tr> </table>	管外径 × 管外径 Tube OD. × Tube OD.		-3		-4		-5		-6		PE-C  <table border="1"> <tr><th colspan="2">管外径 × 管外径 Tube OD. × Tube OD.</th></tr> <tr><td>-3</td><td></td></tr> <tr><td>-4</td><td></td></tr> <tr><td>-5</td><td></td></tr> <tr><td>-6</td><td></td></tr> </table>	管外径 × 管外径 Tube OD. × Tube OD.		-3		-4		-5		-6													
管外径 × 螺纹 Tube OD. × Thread Size																																																							
3-M5																																																							
4-M5																																																							
5-M5																																																							
6-M5																																																							
管外径 × 管外径 Tube OD. × Tube OD.																																																							
-3																																																							
-4																																																							
-5																																																							
-6																																																							
管外径 × 管外径 Tube OD. × Tube OD.																																																							
-3																																																							
-4																																																							
-5																																																							
-6																																																							
管外径 × 管外径 Tube OD. × Tube OD.																																																							
-3																																																							
-4																																																							
-5																																																							
-6																																																							
PY-C  <table border="1"> <tr><th colspan="2">管外径 × 管外径 Tube OD. × Tube OD.</th></tr> <tr><td>-3</td><td></td></tr> <tr><td>-4</td><td></td></tr> <tr><td>-5</td><td></td></tr> <tr><td>-6</td><td></td></tr> </table>	管外径 × 管外径 Tube OD. × Tube OD.		-3		-4		-5		-6		MH  <table border="1"> <tr><th colspan="2">管内径 × 螺纹 Tube ID. × Thread Size</th></tr> <tr><td>3-M5</td><td></td></tr> <tr><td>4-M5</td><td></td></tr> <tr><td>5-M5</td><td></td></tr> <tr><td>6-M5</td><td></td></tr> </table>	管内径 × 螺纹 Tube ID. × Thread Size		3-M5		4-M5		5-M5		6-M5		MHLH  <table border="1"> <tr><th colspan="2">管内径 × 螺纹 Tube ID. × Thread Size</th></tr> <tr><td>3-M5</td><td></td></tr> <tr><td>4-M5</td><td></td></tr> <tr><td>5-M5</td><td></td></tr> <tr><td>6-M5</td><td></td></tr> </table>	管内径 × 螺纹 Tube ID. × Thread Size		3-M5		4-M5		5-M5		6-M5		MHE  <table border="1"> <tr><th colspan="2">管内径 × 螺纹 Tube ID. × Thread Size</th></tr> <tr><td>3-M5</td><td></td></tr> <tr><td>4-M5</td><td></td></tr> <tr><td>5-M5</td><td></td></tr> <tr><td>6-M5</td><td></td></tr> </table>	管内径 × 螺纹 Tube ID. × Thread Size		3-M5		4-M5		5-M5		6-M5													
管外径 × 管外径 Tube OD. × Tube OD.																																																							
-3																																																							
-4																																																							
-5																																																							
-6																																																							
管内径 × 螺纹 Tube ID. × Thread Size																																																							
3-M5																																																							
4-M5																																																							
5-M5																																																							
6-M5																																																							
管内径 × 螺纹 Tube ID. × Thread Size																																																							
3-M5																																																							
4-M5																																																							
5-M5																																																							
6-M5																																																							
管内径 × 螺纹 Tube ID. × Thread Size																																																							
3-M5																																																							
4-M5																																																							
5-M5																																																							
6-M5																																																							
MAU  <table border="1"> <tr><th colspan="2">管内径 × 螺纹 Tube ID. × Thread Size</th></tr> <tr><td>3-M5</td><td></td></tr> <tr><td>4-M5</td><td></td></tr> <tr><td>5-M5</td><td></td></tr> <tr><td>6-M5</td><td></td></tr> </table>	管内径 × 螺纹 Tube ID. × Thread Size		3-M5		4-M5		5-M5		6-M5		MALHE  <table border="1"> <tr><th colspan="2">管内径 × 螺纹 Tube ID. × Thread Size</th></tr> <tr><td>3-M5</td><td></td></tr> <tr><td>4-M5</td><td></td></tr> <tr><td>5-M5</td><td></td></tr> <tr><td>6-M5</td><td></td></tr> </table>	管内径 × 螺纹 Tube ID. × Thread Size		3-M5		4-M5		5-M5		6-M5		MALHU  <table border="1"> <tr><th colspan="2">管内径 × 螺纹 Tube ID. × Thread Size</th></tr> <tr><td>3-M5</td><td></td></tr> <tr><td>4-M5</td><td></td></tr> <tr><td>5-M5</td><td></td></tr> <tr><td>6-M5</td><td></td></tr> </table>	管内径 × 螺纹 Tube ID. × Thread Size		3-M5		4-M5		5-M5		6-M5		MUL/MUT  <table border="1"> <tr><th colspan="2">螺纹 × 螺纹 Thread Size × Thread Size</th></tr> <tr><td>MUL M5-M5</td><td></td></tr> <tr><td>MUT M5-M5</td><td></td></tr> </table>	螺纹 × 螺纹 Thread Size × Thread Size		MUL M5-M5		MUT M5-M5																	
管内径 × 螺纹 Tube ID. × Thread Size																																																							
3-M5																																																							
4-M5																																																							
5-M5																																																							
6-M5																																																							
管内径 × 螺纹 Tube ID. × Thread Size																																																							
3-M5																																																							
4-M5																																																							
5-M5																																																							
6-M5																																																							
管内径 × 螺纹 Tube ID. × Thread Size																																																							
3-M5																																																							
4-M5																																																							
5-M5																																																							
6-M5																																																							
螺纹 × 螺纹 Thread Size × Thread Size																																																							
MUL M5-M5																																																							
MUT M5-M5																																																							

公制铁快插接头 Meter Type Iron One Touch Fitting

IPC	8	-	02
系列号 Series	管外径 Tube OD.		螺纹 Thread

英制铁快插接头 Inch Type Iron One Touch Fitting

IPC	3/8	-	NPT02
系列号 Series	管外径 Tube OD.		螺纹 Thread

技术参数 Specification

主要材质 Main Material	铁、塑料 Iron, Plastic
最高耐压力 Proof Pressure	1.32Mpa
使用压力范围 Pressure Range	0~0.9Mpa
环境及流体温度 Ambient & Fluid Temp.	0~60°C
可配插管类别 Applicable Tube Type	PU软管、PE软管等 PU Tube, PE Tube, etc.
可配插管尺寸 Applicable Tube Size	公制插管、英制插管 Meter Tube, Inch Tube
可配螺纹 Applicable Thread	M、G、PT、NPT、UNI、UNF螺纹等 M、G、PT、NPT、UNI、UNF Thread, etc.

IPC系列铁接头 IPC Series Iron Fitting  <table border="1"> <tr><th colspan="3">管外径 × 螺纹 Tube OD. × Thread Size</th></tr> <tr><td>4-M5</td><td>8-02</td><td>12-03</td></tr> <tr><td>4-01</td><td>8-03</td><td>12-04</td></tr> <tr><td>4-02</td><td>8-04</td><td>14-02</td></tr> <tr><td>6-M5</td><td>10-01</td><td>14-03</td></tr> <tr><td>6-01</td><td>10-02</td><td>14-04</td></tr> <tr><td>6-02</td><td>10-03</td><td>16-02</td></tr> <tr><td>6-03</td><td>10-04</td><td>16-03</td></tr> <tr><td>6-04</td><td>12-01</td><td>16-04</td></tr> <tr><td>8-01</td><td>12-02</td><td>16-06</td></tr> </table>	管外径 × 螺纹 Tube OD. × Thread Size			4-M5	8-02	12-03	4-01	8-03	12-04	4-02	8-04	14-02	6-M5	10-01	14-03	6-01	10-02	14-04	6-02	10-03	16-02	6-03	10-04	16-03	6-04	12-01	16-04	8-01	12-02	16-06	IPCF系列铁接头 IPCF Series Iron Fitting  <table border="1"> <tr><th colspan="3">管外径 × 螺纹 Tube OD. × Thread Size</th></tr> <tr><td>4-M5</td><td>8-02</td><td>12-03</td></tr> <tr><td>4-01</td><td>8-03</td><td>12-04</td></tr> <tr><td>4-02</td><td>8-04</td><td>14-02</td></tr> <tr><td>6-M5</td><td>10-01</td><td>14-03</td></tr> <tr><td>6-01</td><td>10-02</td><td>14-04</td></tr> <tr><td>6-02</td><td>10-03</td><td>16-02</td></tr> <tr><td>6-03</td><td>10-04</td><td>16-03</td></tr> <tr><td>6-04</td><td>12-01</td><td>16-04</td></tr> <tr><td>8-01</td><td>12-02</td><td>16-06</td></tr> </table>	管外径 × 螺纹 Tube OD. × Thread Size			4-M5	8-02	12-03	4-01	8-03	12-04	4-02	8-04	14-02	6-M5	10-01	14-03	6-01	10-02	14-04	6-02	10-03	16-02	6-03	10-04	16-03	6-04	12-01	16-04	8-01	12-02	16-06	IPB系列铁接头 IPB Series Iron Fitting  <table border="1"> <tr><th colspan="3">管外径 × 螺纹 Tube OD. × Thread Size</th></tr> <tr><td>4-M5</td><td>8-02</td><td>12-03</td></tr> <tr><td>4-01</td><td>8-03</td><td>12-04</td></tr> <tr><td>4-02</td><td>8-04</td><td>14-02</td></tr> <tr><td>6-M5</td><td>10-01</td><td>14-03</td></tr> <tr><td>6-01</td><td>10-02</td><td>14-04</td></tr> <tr><td>6-02</td><td>10-03</td><td>16-02</td></tr> <tr><td>6-03</td><td>10-04</td><td>16-03</td></tr> <tr><td>6-04</td><td>12-01</td><td>16-04</td></tr> <tr><td>8-01</td><td>12-02</td><td>16-06</td></tr> </table>	管外径 × 螺纹 Tube OD. × Thread Size			4-M5	8-02	12-03	4-01	8-03	12-04	4-02	8-04	14-02	6-M5	10-01	14-03	6-01	10-02	14-04	6-02	10-03	16-02	6-03	10-04	16-03	6-04	12-01	16-04	8-01	12-02	16-06
管外径 × 螺纹 Tube OD. × Thread Size																																																																																												
4-M5	8-02	12-03																																																																																										
4-01	8-03	12-04																																																																																										
4-02	8-04	14-02																																																																																										
6-M5	10-01	14-03																																																																																										
6-01	10-02	14-04																																																																																										
6-02	10-03	16-02																																																																																										
6-03	10-04	16-03																																																																																										
6-04	12-01	16-04																																																																																										
8-01	12-02	16-06																																																																																										
管外径 × 螺纹 Tube OD. × Thread Size																																																																																												
4-M5	8-02	12-03																																																																																										
4-01	8-03	12-04																																																																																										
4-02	8-04	14-02																																																																																										
6-M5	10-01	14-03																																																																																										
6-01	10-02	14-04																																																																																										
6-02	10-03	16-02																																																																																										
6-03	10-04	16-03																																																																																										
6-04	12-01	16-04																																																																																										
8-01	12-02	16-06																																																																																										
管外径 × 螺纹 Tube OD. × Thread Size																																																																																												
4-M5	8-02	12-03																																																																																										
4-01	8-03	12-04																																																																																										
4-02	8-04	14-02																																																																																										
6-M5	10-01	14-03																																																																																										
6-01	10-02	14-04																																																																																										
6-02	10-03	16-02																																																																																										
6-03	10-04	16-03																																																																																										
6-04	12-01	16-04																																																																																										
8-01	12-02	16-06																																																																																										
IPL系列铁接头 IPL Series Iron Fitting  <table border="1"> <tr><th colspan="3">管外径 × 螺纹 Tube OD. × Thread Size</th></tr> <tr><td>4-M5</td><td>8-02</td><td>12-03</td></tr> <tr><td>4-01</td><td>8-03</td><td>12-04</td></tr> <tr><td>4-02</td><td>8-04</td><td>14-02</td></tr> <tr><td>6-M5</td><td>10-01</td><td>14-03</td></tr> <tr><td>6-01</td><td>10-02</td><td>14-04</td></tr> <tr><td>6-02</td><td>10-03</td><td>16-02</td></tr> <tr><td>6-03</td><td>10-04</td><td>16-03</td></tr> <tr><td>6-04</td><td>12-01</td><td>16-04</td></tr> <tr><td>8-01</td><td>12-02</td><td>16-06</td></tr> </table>	管外径 × 螺纹 Tube OD. × Thread Size			4-M5	8-02	12-03	4-01	8-03	12-04	4-02	8-04	14-02	6-M5	10-01	14-03	6-01	10-02	14-04	6-02	10-03	16-02	6-03	10-04	16-03	6-04	12-01	16-04	8-01	12-02	16-06	IPLF系列铁接头 IPLF Series Iron Fitting  <table border="1"> <tr><th colspan="3">管外径 × 螺纹 Tube OD. × Thread Size</th></tr> <tr><td>4-M5</td><td>8-02</td><td>12-03</td></tr> <tr><td>4-01</td><td>8-03</td><td>12-04</td></tr> <tr><td>4-02</td><td>8-04</td><td>14-02</td></tr> <tr><td>6-M5</td><td>10-01</td><td>14-03</td></tr> <tr><td>6-01</td><td>10-02</td><td>14-04</td></tr> <tr><td>6-02</td><td>10-03</td><td>16-02</td></tr> <tr><td>6-03</td><td>10-04</td><td>16-03</td></tr> <tr><td>6-04</td><td>12-01</td><td>16-04</td></tr> <tr><td>8-01</td><td>12-02</td><td>16-06</td></tr> </table>	管外径 × 螺纹 Tube OD. × Thread Size			4-M5	8-02	12-03	4-01	8-03	12-04	4-02	8-04	14-02	6-M5	10-01	14-03	6-01	10-02	14-04	6-02	10-03	16-02	6-03	10-04	16-03	6-04	12-01	16-04	8-01	12-02	16-06	IPX系列铁接头 IPX Series Iron Fitting  <table border="1"> <tr><th colspan="3">管外径 × 螺纹 Tube OD. × Thread Size</th></tr> <tr><td>4-M5</td><td>8-02</td><td>12-03</td></tr> <tr><td>4-01</td><td>8-03</td><td>12-04</td></tr> <tr><td>4-02</td><td>8-04</td><td>14-02</td></tr> <tr><td>6-M5</td><td>10-01</td><td>14-03</td></tr> <tr><td>6-01</td><td>10-02</td><td>14-04</td></tr> <tr><td>6-02</td><td>10-03</td><td>16-02</td></tr> <tr><td>6-03</td><td>10-04</td><td>16-03</td></tr> <tr><td>6-04</td><td>12-01</td><td>16-04</td></tr> <tr><td>8-01</td><td>12-02</td><td>16-06</td></tr> </table>	管外径 × 螺纹 Tube OD. × Thread Size			4-M5	8-02	12-03	4-01	8-03	12-04	4-02	8-04	14-02	6-M5	10-01	14-03	6-01	10-02	14-04	6-02	10-03	16-02	6-03	10-04	16-03	6-04	12-01	16-04	8-01	12-02	16-06
管外径 × 螺纹 Tube OD. × Thread Size																																																																																												
4-M5	8-02	12-03																																																																																										
4-01	8-03	12-04																																																																																										
4-02	8-04	14-02																																																																																										
6-M5	10-01	14-03																																																																																										
6-01	10-02	14-04																																																																																										
6-02	10-03	16-02																																																																																										
6-03	10-04	16-03																																																																																										
6-04	12-01	16-04																																																																																										
8-01	12-02	16-06																																																																																										
管外径 × 螺纹 Tube OD. × Thread Size																																																																																												
4-M5	8-02	12-03																																																																																										
4-01	8-03	12-04																																																																																										
4-02	8-04	14-02																																																																																										
6-M5	10-01	14-03																																																																																										
6-01	10-02	14-04																																																																																										
6-02	10-03	16-02																																																																																										
6-03	10-04	16-03																																																																																										
6-04	12-01	16-04																																																																																										
8-01	12-02	16-06																																																																																										
管外径 × 螺纹 Tube OD. × Thread Size																																																																																												
4-M5	8-02	12-03																																																																																										
4-01	8-03	12-04																																																																																										
4-02	8-04	14-02																																																																																										
6-M5	10-01	14-03																																																																																										
6-01	10-02	14-04																																																																																										
6-02	10-03	16-02																																																																																										
6-03	10-04	16-03																																																																																										
6-04	12-01	16-04																																																																																										
8-01	12-02	16-06																																																																																										

公制快插接头 Meter Type One Touch Fitting

PC 8 - 02
系列号 管外径 螺纹
Series Tube OD. Thread

英制快插接头 Inch Type One Touch Fitting

PC 3/8 - NPT02
系列号 管外径 螺纹
Series Tube OD. Thread

技术参数 Specification

主要材质 Main Material	铜、塑料 Brass, Plastic
最高耐压力 Proof Pressure	1.32Mpa
使用压力范围 Pressure Range	0~0.9Mpa
环境及流体温度 Ambient & Fluid Temp.	0~60℃
可配插管类别 Applicable Tube Type	PU软管、PE软管等 PU Tube, PE Tube, etc.
可配插管尺寸 Applicable Tube Size	公制插管、英制插管 Meter Tube, Inch Tube
可配螺纹 Applicable Thread	M、G、PT、NPT、UNI、UNF螺纹等 M、G、PT、NPT、UNI、UNF Thread, etc.

PC 螺纹直通
PC Series Male Straight



管外径 × 螺纹 Tube OD. × Thread Size					
公制 Meter Type			英制 Inch Type		
4-M5	8-02	12-03	5/32-M5	5/16-02	1/2-03
4-01	8-03	12-04	5/32-01	5/16-03	1/2-04
4-02	8-04	14-02	5/32-02	5/16-04	3/4-01
6-M5	10-01	14-03	1/4-M5	3/8-01	3/4-02
6-01	10-02	14-04	1/4-01	3/8-02	3/4-03
6-02	10-03	16-02	1/4-02	3/8-03	3/4-04
6-03	10-04	16-03	1/4-03	3/8-04	
6-04	12-01	16-04	1/4-04	1/2-01	
8-01	12-02	16-06	5/16-01	1/2-02	

POC 圆螺纹直通
POC Series Round Male Straight



管外径 × 螺纹 Tube OD. × Thread Size					
公制 Meter Type			英制 Inch Type		
4-M5	8-02	12-03	5/32-M5	5/16-02	1/2-03
4-01	8-03	12-04	5/32-01	5/16-03	1/2-04
4-02	8-04	14-02	5/32-02	5/16-04	3/4-01
6-M5	10-01	14-03	1/4-M5	3/8-01	3/4-02
6-01	10-02	14-04	1/4-01	3/8-02	3/4-03
6-02	10-03	16-02	1/4-02	3/8-03	3/4-04
6-03	10-04	16-03	1/4-03	3/8-04	
6-04	12-01	16-04	1/4-04	1/2-01	
8-01	12-02	16-06	5/16-01	1/2-02	

PCF 内螺纹直通
PCF Series Female Straight



管外径 × 螺纹 Tube OD. × Thread Size					
公制 Meter Type			英制 Inch Type		
4-M5	8-02	12-03	5/32-M5	5/16-02	1/2-03
4-01	8-03	12-04	5/32-01	5/16-03	1/2-04
4-02	8-04	14-02	5/32-02	5/16-04	3/4-01
6-M5	10-01	14-03	1/4-M5	3/8-01	3/4-02
6-01	10-02	14-04	1/4-01	3/8-02	3/4-03
6-02	10-03	16-02	1/4-02	3/8-03	3/4-04
6-03	10-04	16-03	1/4-03	3/8-04	
6-04	12-01	16-04	1/4-04	1/2-01	
8-01	12-02	16-06	5/16-01	1/2-02	

PL L型螺纹二通
PL Male Elbow



管外径 × 螺纹 Tube OD. × Thread Size					
公制 Meter Type			英制 Inch Type		
4-M5	8-02	12-03	5/32-M5	5/16-02	1/2-03
4-01	8-03	12-04	5/32-01	5/16-03	1/2-04
4-02	8-04	14-02	5/32-02	5/16-04	3/4-01
6-M5	10-01	14-03	1/4-M5	3/8-01	3/4-02
6-01	10-02	14-04	1/4-01	3/8-02	3/4-03
6-02	10-03	16-02	1/4-02	3/8-03	3/4-04
6-03	10-04	16-03	1/4-03	3/8-04	
6-04	12-01	16-04	1/4-04	1/2-01	
8-01	12-02	16-06	5/16-01	1/2-02	

PLL 加长L型螺纹二通
PLL Extended Male Elbow



管外径 × 螺纹 Tube OD. × Thread Size					
公制 Meter Type			英制 Inch Type		
4-M5	8-02	12-03	5/32-M5	5/16-02	1/2-03
4-01	8-03	12-04	5/32-01	5/16-03	1/2-04
4-02	8-04	14-02	5/32-02	5/16-04	3/4-01
6-M5	10-01	14-03	1/4-M5	3/8-01	3/4-02
6-01	10-02	14-04	1/4-01	3/8-02	3/4-03
6-02	10-03	16-02	1/4-02	3/8-03	3/4-04
6-03	10-04	16-03	1/4-03	3/8-04	
6-04	12-01	16-04	1/4-04	1/2-01	
8-01	12-02	16-06	5/16-01	1/2-02	

PL-45° L型螺纹二通45°
PL-45° Male Elbow



管外径 × 螺纹 Tube OD. × Thread Size					
公制 Meter Type			英制 Inch Type		
4-M5	8-02	12-03	5/32-M5	5/16-02	1/2-03
4-01	8-03	12-04	5/32-01	5/16-03	1/2-04
4-02	8-04	14-02	5/32-02	5/16-04	3/4-01
6-M5	10-01	14-03	1/4-M5	3/8-01	3/4-02
6-01	10-02	14-04	1/4-01	3/8-02	3/4-03
6-02	10-03	16-02	1/4-02	3/8-03	3/4-04
6-03	10-04	16-03	1/4-03	3/8-04	
6-04	12-01	16-04	1/4-04	1/2-01	
8-01	12-02	16-06	5/16-01	1/2-02	

PLF L型内螺纹二通
PLF Female Elbow



管外径 × 螺纹 Tube OD. × Thread Size					
公制 Meter Type			英制 Inch Type		
4-M5	8-02	12-03	5/32-M5	5/16-02	1/2-03
4-01	8-03	12-04	5/32-01	5/16-03	1/2-04
4-02	8-04	14-02	5/32-02	5/16-04	3/4-01
6-M5	10-01	14-03	1/4-M5	3/8-01	3/4-02
6-01	10-02	14-04	1/4-01	3/8-02	3/4-03
6-02	10-03	16-02	1/4-02	3/8-03	3/4-04
6-03	10-04	16-03	1/4-03	3/8-04	
6-04	12-01	16-04	1/4-04	1/2-01	
8-01	12-02	16-06	5/16-01	1/2-02	

PB T型螺纹三通
PB Male Branch Tee



管外径 × 螺纹 Tube OD. × Thread Size					
公制 Meter Type			英制 Inch Type		
4-M5	8-02	12-03	5/32-M5	5/16-02	1/2-03
4-01	8-03	12-04	5/32-01	5/16-03	1/2-04
4-02	8-04	14-02	5/32-02	5/16-04	3/4-01
6-M5	10-01	14-03	1/4-M5	3/8-01	3/4-02
6-01	10-02	14-04	1/4-01	3/8-02	3/4-03
6-02	10-03	16-02	1/4-02	3/8-03	3/4-04
6-03	10-04	16-03	1/4-03	3/8-04	
6-04	12-01	16-04	1/4-04	1/2-01	
8-01	12-02	16-06	5/16-01	1/2-02	

PBF 内螺纹正三通
PBF Female Branch Tee



管外径 × 螺纹 Tube OD. × Thread Size					
公制 Meter Type			英制 Inch Type		
4-M5	8-02	12-03	5/32-M5	5/16-02	1/2-03
4-01	8-03	12-04	5/32-01	5/16-03	1/2-04
4-02	8-04	14-02	5/32-02	5/16-04	3/4-01
6-M5	10-01	14-03	1/4-M5	3/8-01	3/4-02
6-01	10-02	14-04	1/4-01	3/8-02	3/4-03
6-02	10-03	16-02	1/4-02	3/8-03	3/4-04
6-03	10-04	16-03	1/4-03	3/8-04	
6-04	12-01	16-04	1/4-04	1/2-01	
8-01	12-02	16-06	5/16-01	1/2-02	

PD T型侧螺纹三通
PD Series Male Run Tee



管外径 × 螺纹 Tube OD × Thread Size					
公制 Meter Type			英制 Inch Type		
4-M5	8-02	12-03	5/32-M5	5/16-02	1/2-03
4-01	8-03	12-04	5/32-01	5/16-03	1/2-04
4-02	8-04	14-02	5/32-02	5/16-04	3/4-01
6-M5	10-01	14-03	1/4-M5	3/8-01	3/4-02
6-01	10-02	14-04	1/4-01	3/8-02	3/4-03
6-02	10-03	16-02	1/4-02	3/8-03	3/4-04
6-03	10-04	16-03	1/4-03	3/8-04	
6-04	12-01	16-04	1/4-04	1/2-01	
8-01	12-02	16-06	5/16-01	1/2-02	

PX Y型螺纹三通
PX Series Y Branch



管外径 × 螺纹 Tube OD × Thread Size					
公制 Meter Type			英制 Inch Type		
4-M5	8-02	12-03	5/32-M5	5/16-02	1/2-03
4-01	8-03	12-04	5/32-01	5/16-03	1/2-04
4-02	8-04	14-02	5/32-02	5/16-04	3/4-01
6-M5	10-01	14-03	1/4-M5	3/8-01	3/4-02
6-01	10-02	14-04	1/4-01	3/8-02	3/4-03
6-02	10-03	16-02	1/4-02	3/8-03	3/4-04
6-03	10-04	16-03	1/4-03	3/8-04	
6-04	12-01	16-04	1/4-04	1/2-01	
8-01	12-02	16-06	5/16-01	1/2-02	

PMF 隔板内螺纹直通
PMF Series Bulkhead Connector



管外径 × 螺纹 Tube OD × Thread Size					
公制 Meter Type			英制 Inch Type		
4-M5	8-02	12-03	5/32-M5	5/16-02	1/2-03
4-01	8-03	12-04	5/32-01	5/16-03	1/2-04
4-02	8-04	14-02	5/32-02	5/16-04	3/4-01
6-M5	10-01	14-03	1/4-M5	3/8-01	3/4-02
6-01	10-02	14-04	1/4-01	3/8-02	3/4-03
6-02	10-03	16-02	1/4-02	3/8-03	3/4-04
6-03	10-04	16-03	1/4-03	3/8-04	
6-04	12-01	16-04	1/4-04	1/2-01	
8-01	12-02	16-06	5/16-01	1/2-02	

PH 外六角
PH Series Universal Male Elbow



管外径 × 螺纹 Tube OD × Thread Size					
公制 Meter Type			英制 Inch Type		
4-M5	8-02	12-03	5/32-M5	5/16-02	1/2-03
4-01	8-03	12-04	5/32-01	5/16-03	1/2-04
4-02	8-04	14-02	5/32-02	5/16-04	3/4-01
6-M5	10-01	14-03	1/4-M5	3/8-01	3/4-02
6-01	10-02	14-04	1/4-01	3/8-02	3/4-03
6-02	10-03	16-02	1/4-02	3/8-03	3/4-04
6-03	10-04	16-03	1/4-03	3/8-04	
6-04	12-01	16-04	1/4-04	1/2-01	
8-01	12-02	16-06	5/16-01	1/2-02	

PHF 串联接头
PHF Series Universal Female Elbow



管外径 × 螺纹 Tube OD × Thread Size					
公制 Meter Type			英制 Inch Type		
4-M5	8-02	12-03	5/32-M5	5/16-02	1/2-03
4-01	8-03	12-04	5/32-01	5/16-03	1/2-04
4-02	8-04	14-02	5/32-02	5/16-04	3/4-01
6-M5	10-01	14-03	1/4-M5	3/8-01	3/4-02
6-01	10-02	14-04	1/4-01	3/8-02	3/4-03
6-02	10-03	16-02	1/4-02	3/8-03	3/4-04
6-03	10-04	16-03	1/4-03	3/8-04	
6-04	12-01	16-04	1/4-04	1/2-01	
8-01	12-02	16-06	5/16-01	1/2-02	

PZB 十字螺纹四通
PZB Series Cross Male Connector



管外径 × 螺纹 Tube OD × Thread Size					
公制 Meter Type			英制 Inch Type		
4-M5	8-02	12-03	5/32-M5	5/16-02	1/2-03
4-01	8-03	12-04	5/32-01	5/16-03	1/2-04
4-02	8-04	14-02	5/32-02	5/16-04	3/4-01
6-M5	10-01	14-03	1/4-M5	3/8-01	3/4-02
6-01	10-02	14-04	1/4-01	3/8-02	3/4-03
6-02	10-03	16-02	1/4-02	3/8-03	3/4-04
6-03	10-04	16-03	1/4-03	3/8-04	
6-04	12-01	16-04	1/4-04	1/2-01	
8-01	12-02	16-06	5/16-01	1/2-02	

PWB 五通螺纹
PWB Series Male Five Joints



管外径 × 螺纹 Tube OD × Thread Size					
公制 Meter Type			英制 Inch Type		
4-M5	8-02	12-03	5/32-M5	5/16-02	1/2-03
4-01	8-03	12-04	5/32-01	5/16-03	1/2-04
4-02	8-04	14-02	5/32-02	5/16-04	3/4-01
6-M5	10-01	14-03	1/4-M5	3/8-01	3/4-02
6-01	10-02	14-04	1/4-01	3/8-02	3/4-03
6-02	10-03	16-02	1/4-02	3/8-03	3/4-04
6-03	10-04	16-03	1/4-03	3/8-04	
6-04	12-01	16-04	1/4-04	1/2-01	
8-01	12-02	16-06	5/16-01	1/2-02	

PWD 变径螺纹五通
PWD Series Male Reducer Five Joints



管外径 × 螺纹 Tube OD × Thread Size					
公制 Meter Type			英制 Inch Type		
4-M5	8-02	12-03	5/32-M5	5/16-02	1/2-03
4-01	8-03	12-04	5/32-01	5/16-03	1/2-04
4-02	8-04	14-02	5/32-02	5/16-04	3/4-01
6-M5	10-01	14-03	1/4-M5	3/8-01	3/4-02
6-01	10-02	14-04	1/4-01	3/8-02	3/4-03
6-02	10-03	16-02	1/4-02	3/8-03	3/4-04
6-03	10-04	16-03	1/4-03	3/8-04	
6-04	12-01	16-04	1/4-04	1/2-01	
8-01	12-02	16-06	5/16-01	1/2-02	

PXT Y型螺纹五通
PXT Series Male Thread Five Joints



管外径 × 螺纹 Tube OD × Thread Size				
公制 Meter type		英制 Inch type		
4-01	8-03	5/32-01	5/16-04	
4-02	8-04	5/32-02	3/8-01	
6-M5	10-01	1/4-01	3/8-02	
6-01	10-02	1/4-02	3/8-03	
6-02	10-03	1/4-03	3/8-04	
6-03	10-04	1/4-04	1/2-01	
6-04	12-01	5/16-01	1/2-02	
8-01	12-02	5/16-02	1/2-03	
8-02	12-03	5/16-03	1/2-04	

PGT 外六角双向接头
PTG Series Outer Hexagonal Two Way



管外径 × 螺纹 Tube OD × Thread Size	
公制 Meter Type	英制 Inch Type
4-01	5/32-01
6-01	1/4-01
6-02	1/4-02
8-01	5/16-01
8-02	5/16-02
10-02	3/8-02

PHW(2) F型螺纹串联三通
PHW(2) Series Double Universal Male Elbow



管外径 × 螺纹 Tube OD × Thread Size					
公制 Meter Type			英制 Inch Type		
4-M5	8-02	12-03	5/32-M5	5/16-02	1/2-03
4-01	8-03	12-04	5/32-01	5/16-03	1/2-04
4-02	8-04	14-02	5/32-02	5/16-04	3/4-01
6-M5	10-01	14-03	1/4-M5	3/8-01	3/4-02
6-01	10-02	14-04	1/4-01	3/8-02	3/4-03
6-02	10-03	16-02	1/4-02	3/8-03	3/4-04
6-03	10-04	16-03	1/4-03	3/8-04	
6-04	12-01	16-04	1/4-04	1/2-01	
8-01	12-02	16-06	5/16-01	1/2-02	

PHW(3) F型螺纹串联四通
PHW(3) Series Triple Universal Male Elbow



管外径 × 螺纹 Tube OD × Thread Size					
公制 Meter Type			英制 Inch Type		
4-M5	8-02	12-03	5/32-M5	5/16-02	1/2-03
4-01	8-03	12-04	5/32-01	5/16-03	1/2-04
4-02	8-04	14-02	5/32-02	5/16-04	3/4-01
6-M5	10-01	14-03	1/4-M5	3/8-01	3/4-02
6-01	10-02	14-04	1/4-01	3/8-02	3/4-03
6-02	10-03	16-02	1/4-02	3/8-03	3/4-04
6-03	10-04	16-03	1/4-03	3/8-04	
6-04	12-01	16-04	1/4-04	1/2-01	
8-01	12-02	16-06	5/16-01	1/2-02	

PM 系列隔板直通
PM Series Bulkhead Union



管外径 × 管外径 Tube OD. × Tube OD.	
公制 Meter Type	英制 Inch Type
-4	-5/32
-6	-1/4
-8	-5/16
-10	-3/8
-12	-1/2
-14	-3/4
-16	-1

PLM 隔板弯通
PLM Series Bulkhead Male Elbow



管外径 × 管外径 Tube OD. × Tube OD.	
公制 Meter Type	英制 Inch Type
-4	-5/32
-6	-1/4
-8	-5/16
-10	-3/8
-12	-1/2
-14	-3/4
-16	-1

PLJ L型等径插头
PLJ Series L Union Plug



管外径 × 管外径 Tube OD. × Tube OD.	
公制 Meter Type	英制 Inch Type
4-4	5/32-5/32
6-6	1/4-1/4
8-8	5/16-5/16
10-10	3/8-3/8
12-12	1/2-1/2
14-14	3/4-3/4
16-16	1"-1"

PDJ T型侧边等径插头
PDJ Series D Reducer Plug



管外径 × 管外径 Tube OD. × Tube OD.	
公制 Meter Type	英制 Inch Type
4-4	5/32-5/32
6-6	1/4-1/4
8-8	5/16-5/16
10-10	3/8-3/8
12-12	1/2-1/2
14-14	3/4-3/4
16-16	1"-1"

PBJ T型插头
PBJ Series T Type Plug



管外径 × 管外径 Tube OD. × Tube OD.	
公制 Meter Type	英制 Inch Type
4-4	5/32-5/32
6-6	1/4-1/4
8-8	5/16-5/16
10-10	3/8-3/8
12-12	1/2-1/2
14-14	3/4-3/4
16-16	1"-1"

PYJ Y型插头
PYJ Series Y Plug



管外径 × 管外径 Tube OD. × Tube OD.	
公制 Meter Type	英制 Inch Type
4-4	5/32-5/32
6-6	1/4-1/4
8-8	5/16-5/16
10-10	3/8-3/8
12-12	1/2-1/2
14-14	3/4-3/4
16-16	1"-1"

PXJ 插入型五通
PXJ Series Plug Five Joints



管外径 × 管外径 Tube OD. × Tube OD.	
公制 Meter type	英制 Inch type
4-4	5/32-5/32
6-6	1/4-1/4
8-8	5/16-5/16
10-10	3/8-3/8
12-12	1/2-1/2
14-14	3/4-3/4
16-16	1"-1"

PU 系列直通
PU Series Straight Union



管外径 × 管外径 Tube OD. × Tube OD.	
公制 Meter Type	英制 Inch Type
-4	-5/32
-6	-1/4
-8	-5/16
-10	-3/8
-12	-1/2
-14	-3/4
-16	-1

PG 系列变径直通
PG Series Different Diameter Straight Union



管外径 × 管外径 Tube OD. × Tube OD.		
公制 Meter type	英制 Inch type	
6-4	8-4	1/4-5/32
8-6	10-6	5/16-1/4
10-8	12-8	3/8-5/16
12-10	14-10	1/2-3/8
14-12	16-12	5/16-5/32
16-14		3/8-1/4

PV 直角二通
PV Series Union Elbow



管外径 × 管外径 Tube OD. × Tube OD.	
公制 Meter Type	英制 Inch Type
-4	-5/32
-6	-1/4
-8	-5/16
-10	-3/8
-12	-1/2
-14	-3/4
-16	-1

PVN 直角二通变径
PVN Series Different Diameter Elbow



管外径 × 管外径 Tube OD. × Tube OD.		
公制 Meter type	英制 Inch type	
6-4	8-4	1/4-5/32
8-6	10-6	5/16-1/4
10-8	12-8	3/8-5/16
12-10	14-10	1/2-3/8
14-12	16-12	5/16-5/32
16-14		3/8-1/4

PXL 十字四通
PXL Series Cross Union



管外径 × 管外径 Tube OD. × Tube OD.	
公制 Meter type	英制 Inch type
-4	-5/32
-6	-1/4
-8	-5/16
-10	-3/8
-12	-1/2
-14	-3/4
-16	-1



管外径 × 管外径 Tube OD. × Tube OD.

公制 Meter type	英制 Inch type
-4	-5/32
-6	-1/4
-8	-5/16
-10	-3/8
-12	-1/2
-14	-3/4
-16	-1"



管外径 ϕa × 管外径 ϕb Tube OD. ϕa × Tube OD. ϕb

公制 Meter type	英制 Inch type
6-4	1/4-5/32
8-6	5/16-1/4
10-8	3/8-5/16
12-10	1/2-3/8
8-4	5/16-5/32
10-6	3/8-1/4
12-8	



管外径 ϕa × 管外径 ϕb Tube OD. ϕa × Tube OD. ϕb

公制 Meter type	英制 Inch type
6-4	1/4-5/32
6-6	1/4-1/4
8-4	5/16-5/32
8-6	5/16-1/4
8-8	5/16-5/16



管外径 × 管外径 Tube OD. × Tube OD.

公制 Meter Type	英制 Inch Type
-4	-5/32
-6	-1/4
-8	-5/16
-10	-3/8
-12	-1/2
-14	-3/4
-16	-1"



管外径 ϕa × 管外径 ϕb Tube OD. ϕa × Tube OD. ϕb

公制 Meter type	英制 Inch type	
6-4	8-4	1/4-5/32
8-6	10-6	5/16-1/4
10-8	12-8	3/8-5/16
12-10	14-10	1/2-3/8
14-12	16-12	5/16-5/32
16-14		3/8-1/4



管外径 ϕa × 管外径 ϕb Tube OD. ϕa × Tube OD. ϕb

公制 Meter type	英制 Inch type	
6-4	8-4	1/4-5/32
8-6	10-6	5/16-1/4
10-8	12-8	3/8-5/16
12-10	14-10	1/2-3/8
14-12	16-12	5/16-5/32
16-14		3/8-1/4



管外径 × 管外径 Tube OD. × Tube OD.

公制 Meter type	英制 Inch type
-4	-5/32
-6	-1/4
-8	-5/16
-10	-3/8
-12	-1/2
-14	-3/4
-16	-1"



管外径 ϕa × 管外径 ϕb Tube OD. ϕa × Tube OD. ϕb

公制 Meter type	英制 Inch type	
6-4	8-4	1/4-5/32
8-6	10-6	5/16-1/4
10-8	12-8	3/8-5/16
12-10	14-10	1/2-3/8
8-4	10-6	5/16-5/32
10-6	12-8	3/8-1/4



管外径 × 管外径 Tube OD. × Tube OD.

公制 Meter type	英制 Inch type
-4	-5/32
-6	-1/4
-8	-5/16
-10	-3/8
-12	-1/2
-14	-3/4
-16	-1"



管外径 × 管外径 Tube OD. × Tube OD.

公制 Meter Type	英制 Inch Type
-4	-5/32
-6	-1/4
-8	-5/16
-10	-3/8
-12	-1/2
-14	-3/4
-16	-1"



管外径 × 管外径 Tube OD. × Tube OD.

公制 Meter Type	英制 Inch Type		
-4	6-4	-5/32	1/4-5/32
-6	8-4	-1/4	5/16-5/32
-8	8-6	-5/16	5/16-1/4
-10	10-6	-3/8	3/8-1/4
-12	10-8	-1/2	3/8-5/16
-14	12-8	-3/4	1/2-5/16
-16	12-10	-1"	1/2-3/8



管外径 × 管外径 Tube OD. × Tube OD.

公制 Meter Type	英制 Inch Type
-4	-5/32
-6	-1/4
-8	-5/16
-10	-3/8
-12	-1/2
-14	-3/4
-16	-1"

SL 节流阀 螺纹端进气
SL Series Air From Thread To Tube (Thread Side Inlet)



管外径 × 螺纹 Tube OD. × Thread Size					
公制 Meter Type			英制 Inch Type		
4-M5	8-02	12-03	5/32-M5	5/16-02	1/2-03
4-01	8-03	12-04	5/32-01	5/16-03	1/2-04
4-02	8-04	14-02	5/32-02	5/16-04	3/4-01
6-M5	10-01	14-03	1/4-M5	3/8-01	3/4-02
6-01	10-02	14-04	1/4-01	3/8-02	3/4-03
6-02	10-03	16-02	1/4-02	3/8-03	3/4-04
6-03	10-04	16-03	1/4-03	3/8-04	
6-04	12-01	16-04	1/4-04	1/2-01	
8-01	12-02	16-06	5/16-01	1/2-02	

SL-A 节流阀 气管端进气
SL-A Series Air From Tube To Thread (Pipe Side Inlet)



管外径 × 螺纹 Tube OD. × Thread Size					
公制 Meter Type			英制 Inch Type		
4-M5	8-02	12-03	5/32-M5	5/16-02	1/2-03
4-01	8-03	12-04	5/32-01	5/16-03	1/2-04
4-02	8-04	14-02	5/32-02	5/16-04	3/4-01
6-M5	10-01	14-03	1/4-M5	3/8-01	3/4-02
6-01	10-02	14-04	1/4-01	3/8-02	3/4-03
6-02	10-03	16-02	1/4-02	3/8-03	3/4-04
6-03	10-04	16-03	1/4-03	3/8-04	
6-04	12-01	16-04	1/4-04	1/2-01	
8-01	12-02	16-06	5/16-01	1/2-02	

BC 系列手阀
BC Series Hand Valve



管外径 × 螺纹 Tube OD. × Thread Size			
公制 Meter type		英制 Inch type	
6-M5	8-04	1/4-M5	3/8-01
6-01	10-01	1/4-01	3/8-02
6-02	10-02	1/4-02	3/8-03
6-04	10-04	1/4-04	3/8-04
8-01	12-01	5/16-01	1/2-01
8-02	12-02	5/16-02	1/2-02
8-03	12-03/04	5/16-03	1/2-03
		5/16-04	1/2-04

JSB 按钮阀
JSB Series Push Button Valve



管外径 × 螺纹 Tube OD. × Thread Size					
公制 Meter type			英制 Inch type		
4-M5	6-04	10-03	5/32-M5	1/4-04	3/8-03
4-01	8-01	10-04	5/32-01	5/16-01	3/8-04
4-02	8-02	12-01	5/32-02	5/16-02	1/2-01
6-M5	8-03	12-02	1/4-M5	5/16-03	1/2-02
6-01	8-04	12-03	1/4-01	5/16-04	1/2-03
6-02	10-01	12-04	1/4-02	3/8-01	1/2-04
6-03	10-02		1/4-03	3/8-02	

JSB-L 按钮阀-加长
JSB-L Series Long Type Push Button Valve



管外径 × 螺纹 Tube OD. × Thread Size					
公制 Meter type			英制 Inch type		
4-M5	6-04	10-03	5/32-M5	1/4-04	3/8-03
4-01	8-01	10-04	5/32-01	5/16-01	3/8-04
4-02	8-02	12-01	5/32-02	5/16-02	1/2-01
6-M5	8-03	12-02	1/4-M5	5/16-03	1/2-02
6-01	8-04	12-03	1/4-01	5/16-04	1/2-03
6-02	10-01	12-04	1/4-02	3/8-01	1/2-04
6-03	10-02		1/4-03	3/8-02	

LSC 自由旋转型节流阀(螺纹端进气)
LSC Series Free Rotation Speed Control Valve (Thread Side Inlet)



管外径 × 螺纹 Tube OD. × Thread Size					
公制 Meter type			英制 Inch type		
4-M5	6-04	10-03	5/32-M5	1/4-04	3/8-03
4-01	8-01	10-04	5/32-01	5/16-01	3/8-04
4-02	8-02	12-01	5/32-02	5/16-02	1/2-01
6-M5	8-03	12-02	1/4-M5	5/16-03	1/2-02
6-01	8-04	12-03	1/4-01	5/16-04	1/2-03
6-02	10-01	12-04	1/4-02	3/8-01	1/2-04
6-03	10-02		1/4-03	3/8-02	

HVSF 节流阀(螺纹端进气)
HVSF Series Speed Control Valve (Thread Side Inlet)



管外径 × 螺纹 Tube OD. × Thread Size					
公制 Meter Type			英制 Inch Type		
4-M5	8-02	12-03	5/32-M5	5/16-02	1/2-03
4-01	8-03	12-04	5/32-01	5/16-03	1/2-04
4-02	8-04	14-02	5/32-02	5/16-04	3/4-01
6-M5	10-01	14-03	1/4-M5	3/8-01	3/4-02
6-01	10-02	14-04	1/4-01	3/8-02	3/4-03
6-02	10-03	16-02	1/4-02	3/8-03	3/4-04
6-03	10-04	16-03	1/4-03	3/8-04	
6-04	12-01	16-04	1/4-04	1/2-01	
8-01	12-02	16-06	5/16-01	1/2-02	

HVSF-A 节流阀(气管端进气)
HVSF-A Series Speed Control Valve (Pipe Side Inlet)



管外径 × 螺纹 Tube OD. × Thread Size					
公制 Meter Type			英制 Inch Type		
4-M5	8-02	12-03	5/32-M5	5/16-02	1/2-03
4-01	8-03	12-04	5/32-01	5/16-03	1/2-04
4-02	8-04	14-02	5/32-02	5/16-04	3/4-01
6-M5	10-01	14-03	1/4-M5	3/8-01	3/4-02
6-01	10-02	14-04	1/4-01	3/8-02	3/4-03
6-02	10-03	16-02	1/4-02	3/8-03	3/4-04
6-03	10-04	16-03	1/4-03	3/8-04	
6-04	12-01	16-04	1/4-04	1/2-01	
8-01	12-02	16-06	5/16-01	1/2-02	

HVSS 系列手阀
HVSS Series Hand Valve



螺纹 × 螺纹 Thread Size × Thread Size					
公制 Meter Type			英制 Inch Type		
4-M5	8-02	12-03	5/32-M5	5/16-02	1/2-03
4-01	8-03	12-04	5/32-01	5/16-03	1/2-04
4-02	8-04	14-02	5/32-02	5/16-04	3/4-01
6-M5	10-01	14-03	1/4-M5	3/8-01	3/4-02
6-01	10-02	14-04	1/4-01	3/8-02	3/4-03
6-02	10-03	16-02	1/4-02	3/8-03	3/4-04
6-03	10-04	16-03	1/4-03	3/8-04	
6-04	12-01	16-04	1/4-04	1/2-01	
8-01	12-02	16-06	5/16-01	1/2-02	

HVFF 系列手阀
HVFF Series Hand Valve



管外径 × 管外径 Tube OD. × Tube OD.	
公制 Meter type	英制 Inch type
-4	-5/32
-6	-1/4
-8	-5/16
-10	-3/8
-12	-1/2
-14	-3/4
-16	-1"

PA 系列手阀
PA Series Hand Valve



管外径 × 管外径 Tube OD. × Tube OD.	
公制 Meter type	英制 Inch type
-4	-5/32
-6	-1/4
-8	-5/16
-10	-3/8
-12	-1/2
-14	-3/4
-16	-1"

BUC 系列手阀
BUC Series Hand Valve



管外径 × 管外径 Tube OD. × Tube OD.	
公制 Meter type	英制 Inch type
-4	-5/32
-6	-1/4
-8	-5/16
-10	-3/8
-12	-1/2
-14	-3/4
-16	-1"

公制微型快插接头 Meter Type Mini One Touch Fitting

KJS **4** - **M3**
系列号 管外径 螺纹
Series Tube OD. Thread

英制微型快插接头 Inch Type Mini One Touch Fitting

KJS **5/32** - **NPT01**
系列号 管外径 螺纹
Series Tube OD. Thread

技术参数 Specification

主要材质 Main Material	铜、塑料 Brass, Plastic
最高耐压力 Proof Pressure	1.32Mpa
使用压力范围 Pressure Range	0~0.9Mpa
环境及流体温度 Ambient & Fluid Temp.	0~60℃
可配插管类别 Applicable Tube Type	PU软管、PE软管等 PU Tube, PE Tube, etc.
可配插管尺寸 Applicable Tube Size	公制插管、英制插管 Meter Tube, Inch Tube
可配螺纹 Applicable Thread	M、G、PT、NPT、UNI、UNF螺纹等 M、G、PT、NPT、UNI、UNF Thread, etc.

KJH 	管外径 × 螺纹 Tube OD. × Thread Size	
	03-M3	04-M5
	03-M5	04-M6
	03-M6	04-01S
	03-01S	06-M5
	23-M3	06-M6
	23-M5	06-01S
	23-M6	
	23-01S	
	04-M3	

KJS 	管外径 × 螺纹 Tube OD. × Thread Size	
	03-M3	06-M6
	03-M5	06-01S
	23-M3	
	23-M5	
	04-M3	
	04-M5	
	04-M6	
	04-01S	
	06-M5	

KJF 	管外径 × 螺纹 Tube OD. × Thread Size	
	03-M3	06-M6
	03-M5	06-01S
	23-M3	
	23-M5	
	04-M3	
	04-M5	
	04-M6	
	04-01S	
	06-M5	

KJL 	管外径 × 螺纹 Tube OD. × Thread Size	
	03-M3	04-M5
	03-M5	04-M6
	03-M6	04-01S
	03-01S	06-M5
	23-M3	06-M6
	23-M5	06-01S
	23-M6	
	23-01S	
	04-M3	

KJW 加长型 Extended Type 	管外径 × 螺纹 Tube OD. × Thread Size	
	03-M3	04-M5
	03-M5	04-M6
	03-M6	04-01S
	03-01S	06-M5
	23-M3	06-M6
	23-M5	06-01S
	23-M6	
	23-01S	
	04-M3	

KJT 	管外径 × 螺纹 Tube OD. × Thread Size	
	03-M3	04-M3
	03-M5	04-M5
	03-M6	04-M6
	03-01S	04-01S
	23-M3	06-M5
	23-M5	06-M6
	23-M6	06-01S
	23-01S	

KJY 	管外径 × 螺纹 Tube OD. × Thread Size	
	04-M3	
	04-M5	
	04-M6	
	04-01S	
	06-M5	
	06-M6	
	06-01S	

KJU 	管外径 × 螺纹 Tube OD. × Thread Size	
	04-M3	
	04-M5	
	04-M6	
	04-01S	
	06-M5	
	06-M6	
	06-01S	

KJE 	管外径 × 管外径 Tube OD. × Tube OD.	
	03-00	
	23-00	
	04-00	
	06-00	

KJU 	管外径 × 管外径 Tube OD. × Tube OD.	
	KJU04-99	
	KJU06-99	

KJX 变径型 Different Dia. Type 	管外径 ϕa × 管外径 ϕb Tube OD. ϕa × Tube OD. ϕb	
	KJX04-03	
	KJX04-23	
	KJX04-06	
	KJX06-04	

KJH 	管外径 × 管外径 Tube OD. × Tube OD.	
	03-00	
	23-00	
	04-00	
	06-00	
	03-04	

KJT 	管外径 × 管外径 Tube OD. × Tube OD.	
	03-00	
	23-00	
	04-00	
	06-00	

KJU 	管外径 ϕa × 管外径 ϕb Tube OD. ϕa × Tube OD. ϕb	
	03-00	03-04
	23-00	23-04
	04-00	04-06
	06-00	

KQ2C 	管外径 × 管外径 Tube OD. × Tube OD.	
	04-00	
	06-00	
	08-00	
	10-00	
	12-00	

公制快插接头 Meter Type One Touch Fitting

KQ2H **8** - **02**
系列号 管外径 螺纹
Series Tube OD. Thread

英制快插接头 Inch Type One Touch Fitting

KQ2H **3/8** - **NPT02**
系列号 管外径 螺纹
Series Tube OD. Thread

技术参数 Specification

主要材质 Main Material	铜、塑料 Brass, Plastic
最高耐压力 Proof Pressure	1.32Mpa
使用压力范围 Pressure Range	0~0.9Mpa
环境及流体温度 Ambient & Fluid Temp.	0~60℃
可配插管类别 Applicable Tube Type	PU软管、PE软管等 PU Tube, PE Tube, etc.
可配插管尺寸 Applicable Tube Size	公制插管、英制插管 Meter Tube, Inch Tube
可配螺纹 Applicable Thread	M、G、PT、NPT、UNI、UNF螺纹等 M、G、PT、NPT、UNI、UNF Thread, etc.

	KQ2H		
	管外径 × 螺纹 Tube OD. × Thread Size		
	04-M5	08-01S	12-04S
	04-M6	08-02S	16-03S
	04-01S	08-03S	16-04S
	04-02S	10-01S	
	06-M5	10-02S	
	06-M6	10-03S	
	06-01S	10-04S	
	06-02S	12-02S	
06-03S	12-03S		

	KQ2S		
	管外径 × 螺纹 Tube OD. × Thread Size		
	04-M5	08-02S	16-03S
	04-M6	08-03S	16-04S
	04-01S	10-01S	
	04-02S	10-02S	
	06-M5	10-03S	
	06-M6	10-04S	
	06-01S	12-02S	
	06-02S	12-03S	
08-01S	12-04S		

	KQ2F		
	管外径 × 螺纹 Tube OD. × Thread Size		
	04-M5	08-03	16-04
	04-01	10-01	
	04-02	10-02	
	06-M5	10-03	
	06-01	10-04	
	06-02	12-02	
	06-03	12-03	
	08-01	12-04	
08-02	16-03		

	KQ2E	
	管外径 × 螺纹 Tube OD. × Thread Size	
	04-M5	10-02
	04-01	10-03
	04-02	10-04
	06-01	12-03
	06-02	12-04
	06-03	16-02
	08-01	16-03
	08-02	16-04
08-03		

	KQ2E	
	管外径 × 管外径 Tube OD. × Tube OD.	
	04-00	
	06-00	
	08-00	
	10-00	
	12-00	
16-00		

	KQ2L		
	管外径 × 螺纹 Tube OD. × Thread Size		
	04-M5	08-01S	12-04S
	04-M6	08-02S	16-03S
	04-01S	08-03S	16-04S
	04-02S	10-01S	
	06-M5	10-02S	
	06-M6	10-03S	
	06-01S	10-04S	
	06-02S	12-02S	
06-03S	12-03S		

	KQ2W 加长型 Extended Type		
	管外径 × 螺纹 Tube OD. × Thread Size		
	04-M5	08-01S	12-04S
	04-M6	08-02S	16-03S
	04-01S	08-03S	16-04S
	04-02S	10-01S	
	06-M5	10-02S	
	06-M6	10-03S	
	06-01S	10-04S	
	06-02S	12-02S	
06-03S	12-03S		

	KQ2K		
	管外径 × 螺纹 Tube OD. × Thread Size		
	04-M5	08-01S	12-04S
	04-M6	08-02S	16-03S
	04-01S	08-03S	16-04S
	04-02S	10-01S	
	06-M5	10-02S	
	06-M6	10-03S	
	06-01S	10-04S	
	06-02S	12-02S	
06-03S	12-03S		

	KQ2LF		
	管外径 × 螺纹 Tube OD. × Thread Size		
	04-M5	08-03	16-04
	04-01	10-01	
	04-02	10-02	
	06-M5	10-03	
	06-01	10-04	
	06-02	12-02	
	06-03	12-03	
	08-01	12-04	
08-02	16-03		

	KQ2LE	
	管外径 × 管外径 Tube OD. × Tube OD.	
	04-00	
	06-00	
	08-00	
	10-00	
	12-00	

	KQ2T		
	管外径 × 螺纹 Tube OD. × Thread Size		
	04-M5	08-01S	12-04S
	04-M6	08-02S	16-03S
	04-01S	08-03S	16-04S
	04-02S	10-01S	
	06-M5	10-02S	
	06-M6	10-03S	
	06-01S	10-04S	
	06-02S	12-02S	
06-03S	12-03S		

	KQ2Y		
	管外径 × 螺纹 Tube OD. × Thread Size		
	04-M5	08-01S	12-04S
	04-M6	08-02S	16-03S
	04-01S	08-03S	16-04S
	04-02S	10-01S	
	06-M5	10-02S	
	06-M6	10-03S	
	06-01S	10-04S	
	06-02S	12-02S	
06-03S	12-03S		

	KQ2U	
	管外径 × 螺纹 Tube OD. × Thread Size	
	04-M5	08-02S
	04-01S	08-03S
	04-02S	10-01S
	04-03S	10-02S
	06-M5	10-03S
	06-01S	10-04S
	06-02S	12-02S
	06-03S	12-03S
08-01S	12-04S	

	KQ2UD	
	管外径 × 螺纹 Tube OD. × Thread Size	
	04-M5	
	04-M6	
	04-01S	
	04-02S	
	06-M5	
	06-M6	
06-01S		
06-02S		

	KQ2V	
	管外径 × 螺纹 Tube OD. × Thread Size	
	04-M5	08-02S
	04-M6	08-03S
	04-01S	10-01S
	04-02S	10-02S
	06-M5	10-03S
	06-M6	12-03S
	06-01S	12-04S
	06-02S	
08-01S		

KQ2VF



管外径 × 螺纹 Tube OD × Thread Size	
04-M5	10-02S
04-M6	12-03S
04-01S	12-04S
06-M5	
06-M6	
06-01S	
08-01S	
08-02S	
10-01S	

KQ2VS



管外径 × 螺纹 Tube OD × Thread Size	
04-M5	08-02S
04-M6	08-03S
04-01S	10-01S
04-02S	10-02S
06-M5	10-03S
06-M6	12-02S
06-01S	12-03S
06-02S	
08-01S	

KQ2Z



管外径 × 螺纹 Tube OD × Thread Size	
04-M5	08-02S
04-M6	08-03S
04-01S	10-01S
04-02S	10-02S
06-M5	10-03S
06-M6	12-02S
06-01S	12-03S
06-02S	
08-01S	

KQ2ZS



管外径 × 螺纹 Tube OD × Thread Size	
04-M5	08-02S
04-M6	08-03S
04-01S	10-01S
04-02S	10-02S
06-M5	10-03S
06-M6	12-02S
06-01S	12-03S
06-02S	
08-01S	

KQ2ZF



管外径 × 螺纹 Tube OD × Thread Size	
04-M5	10-02S
04-M6	12-02S
04-01S	12-03S
06-M5	
06-M6	
06-01S	
08-01S	
08-02S	
10-01S	

KQ2D



管外径 × 螺纹 Tube OD × Thread Size		
04-M5	08-01S	12-04S
04-M6	08-02S	
04-01S	08-03S	
04-02S	10-01S	
06-M5	10-02S	
06-M6	10-03S	
06-01S	10-04S	
06-02S	12-02S	
06-03S	12-03S	

KQ2LU



管外径 × 螺纹 Tube OD × Thread Size		
04-M5	08-01S	12-04S
04-M6	08-02S	
04-01S	08-03S	
04-02S	10-01S	
06-M5	10-02S	
06-M6	10-03S	
06-01S	10-04S	
06-02S	12-02S	
06-03S	12-03S	

KQ2VD



管外径 × 螺纹 Tube OD × Thread Size	
04-01S	08-04S
04-02S	10-02S
04-03S	10-03S
06-01S	10-04S
06-02S	12-02S
06-03S	12-03S
08-01S	12-04S
08-02S	
08-03S	

KQ2VT



管外径 × 螺纹 Tube OD × Thread Size	
04-01S	08-04S
04-02S	10-02S
04-03S	10-03S
06-01S	10-04S
06-02S	12-02S
06-03S	12-03S
08-01S	12-04S
08-02S	
08-03S	

KQ2ZD



管外径 × 螺纹 Tube OD × Thread Size	
04-01S	08-04S
04-02S	10-02S
04-03S	10-03S
06-01S	10-04S
06-02S	12-02S
06-03S	12-03S
08-01S	12-04S
08-02S	
08-03S	

KQ2ZT



管外径 × 螺纹 Tube OD × Thread Size	
04-01S	08-04S
04-02S	10-02S
04-03S	10-03S
06-01S	10-04S
06-02S	12-02S
06-03S	12-03S
08-01S	12-04S
08-02S	
08-03S	

KQ2L



管外径 ϕa × 管外径 ϕb Tube OD ϕa × Tube OD ϕb	
04-06	04-99
04-08	06-99
06-08	08-99
06-10	10-99
08-10	12-99
08-12	
10-12	
12-16	

KQ2W
加长型 Extended Type



管外径 × 管外径 Tube OD × Tube OD	
04-99	
06-99	
08-99	
10-99	
12-99	

KQ2U



管外径 × 管外径 Tube OD × Tube OD	
04-99	
06-99	
08-99	
10-99	
12-99	

KQ2X
变径型 Different Dia. Type



管外径 ϕa × 管外径 ϕb Tube OD ϕa × Tube OD ϕb	
04-06	
06-08	
08-10	
10-12	

KQ2UW
加长型 Extended Type



管外径 × 管外径 Tube OD × Tube OD	
04-99	
06-99	
08-99	
10-99	
12-99	

KQ2XD



管外径 ϕa × 管外径 ϕb Tube OD ϕa × Tube OD ϕb	
04-04	
04-06	
04-08	
06-06	
06-08	
06-10	
06-12	

KQ2H



管外径 × 管外径 Tube OD × Tube OD	
04-00	06-10
06-00	08-10
08-00	08-12
10-00	10-12
12-00	12-16
16-00	
04-06	
04-08	
06-08	

KQ2L



管外径 × 管外径 Tube OD × Tube OD	
04-00	
06-00	
08-00	
10-00	
12-00	
16-00	

KQ2T



管外径 ϕa × 管外径 ϕb Tube OD ϕa × Tube OD ϕb	
04-00	12-10
06-00	04-06
08-00	06-08
10-00	08-10
12-00	10-12
16-00	16-12
06-04	
08-06	
10-08	

KQ2T-W



管外径 × 管外径 Tube OD × Tube OD	
04-00	
06-00	
08-00	
10-00	
12-00	

KQ2T-X

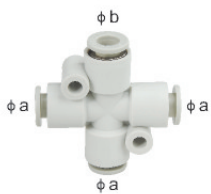

管外径 $\phi a \times$ 管外径 ϕb Tube OD $\phi a \times$ Tube OD ϕb	
06-04	
08-06	
10-08	
12-10	

KQ2T-Y

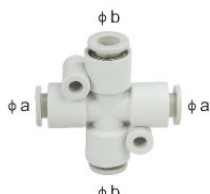

管外径 $\phi a \times$ 管外径 ϕb Tube OD $\phi a \times$ Tube OD ϕb	
06-04	
08-06	
10-08	
12-10	

KQ2T-Z

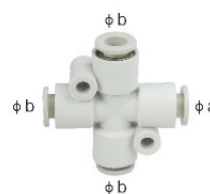

管外径 $\phi a \times$ 管外径 ϕb Tube OD $\phi a \times$ Tube OD ϕb	
06-04	
08-06	
10-08	
12-10	

KQ2U



管外径 $\phi a \times$ 管外径 ϕb Tube OD $\phi a \times$ Tube OD ϕb	
04-00	04-06
06-00	06-08
08-00	08-10
10-00	10-12
12-00	
16-00	

KQ2UD



管外径 $\phi a \times$ 管外径 ϕb Tube OD $\phi a \times$ Tube OD ϕb	
04-06	
06-08	

KQ2R



管外径 $\phi a \times$ 管外径 ϕb Tube OD $\phi a \times$ Tube OD ϕb	
04-06	10-12
04-08	
04-10	
06-04	
06-08	
06-10	
06-12	
08-10	
08-12	

KQ2D



管外径 \times 管外径 Tube OD \times Tube OD	
04-00	
06-00	
08-00	
10-00	
12-00	

KQ2LU



管外径 \times 管外径 Tube OD \times Tube OD	
04-00	
06-00	
08-00	
10-00	
12-00	

KQ2P



管外径 \times 管外径 Tube OD \times Tube OD	
04	
06	
08	
10	
12	

旋转接头 Rotary One Touch Fitting

RC
标准型 Standard Type



管外径 \times 螺纹 Tube OD \times Thread Size		
4-M5	8-02	12-03
4-01	8-03	12-04
4-02	8-04	14-02
6-M5	10-01	14-03
6-01	10-02	14-04
6-02	10-03	16-02
6-03	10-04	16-03
6-04	12-01	16-04
8-01	12-02	16-06

RL
标准型 Standard Type



管外径 \times 螺纹 Tube OD \times Thread Size		
4-M5	8-02	12-03
4-01	8-03	12-04
4-02	8-04	14-02
6-M5	10-01	14-03
6-01	10-02	14-04
6-02	10-03	16-02
6-03	10-04	16-03
6-04	12-01	16-04
8-01	12-02	16-06

RMF



管外径 \times 螺纹 Tube OD \times Thread Size	
01-01	
02-02	
03-03	
04-04	
04-03	
03-02	
02-01	

HRC
高速型 High Speed Type



管外径 \times 螺纹 Tube OD \times Thread Size		
4-M5	8-02	12-03
4-01	8-03	12-04
4-02	8-04	14-02
6-M5	10-01	14-03
6-01	10-02	14-04
6-02	10-03	16-02
6-03	10-04	16-03
6-04	12-01	16-04
8-01	12-02	16-06

HRL
高速型 High Speed Type



管外径 \times 螺纹 Tube OD \times Thread Size		
4-M5	8-02	12-03
4-01	8-03	12-04
4-02	8-04	14-02
6-M5	10-01	14-03
6-01	10-02	14-04
6-02	10-03	16-02
6-03	10-04	16-03
6-04	12-01	16-04
8-01	12-02	16-06

MQR
低回转矩旋转型
Low Torque Rotary Type



管外径 \times 螺纹 Tube OD \times Thread Size	
1-M5	
2-M5	
4-M5	
8-M5	
12-M5	
16-M5	

KSH
标准型 Standard Type



管外径 \times 螺纹 Tube OD \times Thread Size	
04-M5	08-03S
04-M6	10-02S
04-01S	10-03S
06-M5	10-04S
06-M6	12-03S
06-01S	12-04S
06-02S	
08-01S	
08-02S	

KXH
高速型 High Speed Type



管外径 \times 螺纹 Tube OD \times Thread Size	
04-M5	08-03S
04-M6	10-02S
04-01S	10-03S
06-M5	10-04S
06-M6	12-03S
06-01S	12-04S
06-02S	
08-01S	
08-02S	

KSL
标准型 Standard Type



管外径 \times 螺纹 Tube OD \times Thread Size	
04-M5	08-03S
04-M6	10-02S
04-01S	10-03S
06-M5	10-04S
06-M6	12-03S
06-01S	12-04S
06-02S	
08-01S	
08-02S	

KXL
高速型 High Speed Type



管外径 \times 螺纹 Tube OD \times Thread Size	
04-M5	08-03S
04-M6	10-02S
04-01S	10-03S
06-M5	10-04S
06-M6	12-03S
06-01S	12-04S
06-02S	
08-01S	
08-02S	

流量控制阀 Flow Control Valve

AS01F**



管外径 × 螺纹
Tube OD × Thread Size

M3-04	01-08S
M5-04	02-08S
01-04S	03-08S
02-04S	01-10S
M3-06	02-10S
M5-06	03-10S
01-06S	04-10S
02-06S	03-12S
03-06S	04-12S

出气 Outlet
进气 Inlet

AS11F**



管外径 × 螺纹
Tube OD × Thread Size

M3-04	01-08S
M5-04	02-08S
01-04S	03-08S
02-04S	01-10S
M3-06	02-10S
M5-06	03-10S
01-06S	04-10S
02-06S	03-12S
03-06S	04-12S

进气 Inlet
出气 Outlet

AS*01F-D**



管外径 × 螺纹
Tube OD × Thread Size

01-04S-D	03-08S-D
01-06S-D	03-010S-D
01-08S-D	03-12S-D
01-10S-D	04-10S-D
02-04S-D	04-12S-D
02-06S-D	
02-08S-D	
02-10S-D	
03-06S-D	

AS



管外径 × 螺纹
Tube OD × Thread Size

M3-04	01-08S
M5-04	02-08S
01-04S	03-08S
02-04S	01-10S
M3-06	02-10S
M5-06	03-10S
01-06S	04-10S
02-06S	03-12S
03-06S	04-12S

ASN2



管外径 × 螺纹
Tube OD × Thread Size

M5	
01	
02	
03	
04	

AS1F**



管外径 × 管外径
Tube OD × Tube OD

AS1001F-04	AS4001F-10
AS2001F-04	AS3001F-12
AS1001F-06	AS4001F-12
AS2001F-06	
AS2051F-06	
AS3001F-06	
AS2051F-08	
AS3001F-08	
AS3001F-10	

AS1001F~4001F



管外径 × 管外径
Tube OD × Tube OD

AS1001F-23-3	AS3001F-10-3
AS1001F-04-3	AS3001F-12-3
AS1001F-06-3	AS4001F-10-3
AS2001F-04-3	AS4001F-12-3
AS2001F-06-3	
AS2051F-06-3	
AS2051F-08-3	
AS3001F-08-3	
AS3001F-08-3	

AQ



管外径 × 管外径
Tube OD × Tube OD

04-00	
06-00	
06-00	
04-04	
06-06	
06-06	

VHK

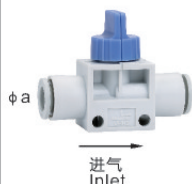

管外径 φa × 管外径 φb
Tube OD φa × Tube OD φb

04F-04F	
06F-04F	
06F-06F	
08F-06F	
08F-08F	
10F-08F	
10F-10F	
12F-10F	
12F-12F	

进气 Inlet

VHK

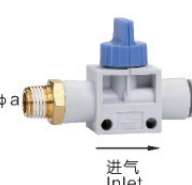

螺纹 φa × 管外径 φb
Thread Size φa × Tube OD φb

M5-04F	03S-06F
M5-06F	03S-08F
01S-04F	03S-10F
01S-06F	03S-12F
01S-08F	04S-10F
02S-06F	04S-12F
02S-08F	
02S-10F	
02S-12F	

φa
φb
进气 Inlet

VHK

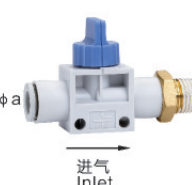

管外径 φa × 螺纹 φb
Tube OD φa × Thread Size φb

04F-M5	10F-02S
04F-01S	10F-03S
06F-M5	10F-04S
06F-01S	12F-02S
06F-02S	12F-03S
06F-03S	12F-04S
08F-01S	
08F-02S	
08F-03S	

φa
φb
进气 Inlet

VHK

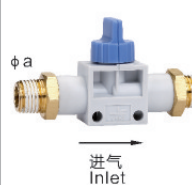

螺纹 φa × 螺纹 φb
Thread Size φa × Thread Size φb

M5-M5	
01S-M5	
01S-01S	
02S-01S	
02S-02S	
03S-02S	
03S-03S	
04S-03S	
04S-04S	

φa
φb
进气 Inlet

ASV



管外径 × 螺纹
Tube OD × Thread Size

120F-M3	510F-04
220F-M5	
310F-01	
310F-02	
410F-01	
410F-02	
410F-03	
510F-02	
510F-03	

ASD



管外径 × 螺纹
Tube OD × Thread Size

230F-M5	
330F-01	
430F-02	
530F-02	
530F-03	
630F-04	

RVU



管外径 × 管外径
Tube OD φa × Tube OD φb

RVU4-4	
RVU6-6	
RVU8-8	
RVU8-6	
RVUM4-4	
RVUM6-6	
RVUM8-8	
RVUM8-6	

单向阀 Check Valve

AKH-A

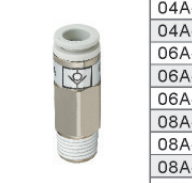

管外径 × 螺纹
Tube OD × Thread Size

04A-M5	10A-03S
04A-01S	10A-04S
06A-M5	12A-03S
06A-01S	12A-04S
06A-02S	
08A-01S	
08A-02S	
08A-03S	
10A-02S	

AKH-B



管外径 × 螺纹
Tube OD × Thread Size

04B-M5	10B-03S
04B-01S	10B-04S
06B-M5	12B-03S
06B-01S	12B-04S
06B-02S	
08B-01S	
08B-02S	
08B-03S	
10B-02S	

AKB



螺纹 × 螺纹
Thread Size × Thread Size

01A-01S	
02A-02S	
03A-03S	
04A-04S	
01B-01S	
02B-02S	
03B-03S	
04B-04S	



AKH









管外径 × 管外径
Tube OD × Tube OD

04-00	
06-00	
08-00	
10-00	
12-00	

公制内置封闭式快插接头 Meter Type Stop Fitting

	管外径 × 螺纹 Tube OD × Thread Size			管外径 × 螺纹 Tube OD × Thread Size			管外径 × 管外径 Tube OD × Tube OD	
	04-M5	10-03S		04-M5	10-03S		04-00	
	04-01S	12-03S		04-01S	12-03S		06-00	
	06-M5	12-04S		06-M5	12-04S		08-00	
	06-01S			06-01S			10-00	
	06-02S			06-02S			12-00	
	08-01S			08-01S				
	08-02S			08-02S				
08-03S		08-03S						
10-02S		10-02S						

	管外径 × 螺纹 Tube OD × Thread Size			管外径 × 管外径 Tube OD × Tube OD			管外径 × 管外径 Tube OD × Tube OD	
		04-02			04-00		04-99	
		06-02			06-00		06-99	
		08-03			08-00		08-99	
		10-03			10-00		10-99	
	12-03		12-00	12-99				

	管外径 × 螺纹 Tube OD × Thread Size				管外径 × 管外径 Tube OD × Tube OD				管外径 × 螺纹 Tube OD × Thread Size		
	4-M5	8-02	12-03		4	4	4-M5		8-02	12-03	
	4-01	8-03	12-04		6	6	4-01		8-03	12-04	
	4-02	8-04	14-02		8	8	4-02		8-04	14-02	
	6-M5	10-01	14-03		10	10	6-M5		10-01	14-03	
	6-01	10-02	14-04		12	12	6-01		10-02	14-04	
	6-02	10-03	16-02		14	14	6-02		10-03	16-02	
	6-03	10-04	16-03		16	16	6-03		10-04	16-03	
	6-04	12-01	16-04				6-04		12-01	16-04	
	8-01	12-02	16-06				8-01		12-02	16-06	

压缩空气管道接头 Compressed Air System Fitting

	管外径 × 螺纹 Tube OD × Thread Size				管外径 × 螺纹 Tube OD × Thread Size				管外径 × 管外径 Tube OD × Tube OD	
	20-G1/2	50-G2			20-G1/2	50-G2	20-20			
	20-G3/4	63-G2			20-G3/4	63-G2	25-25			
	20-G1				20-G1		32-32			
	25-G1/2				25-G1/2		40-40			
	25-G3/4				25-G3/4		50-50			
	25-G1				25-G1		63-63			
	32-G1				32-G1					
	40-G1				40-G1					

	管外径 × 管外径 Tube OD × Tube OD			管外径 × 螺纹 Tube OD × Thread Size			管外径 × 管外径 Tube OD × Tube OD		
	20	20-20		25	1/2		25	20	50
	25	25-25		32	3/4		32	20	40
	32	32-32		40	1"		32	25	60
	40	40-40		50	1-1/2		40	20	63
	50	50-50		63	2"		50	25	63





	管外径 × 管外径 Tube OD × Tube OD			管外径 × 管外径 Tube OD × Tube OD			螺纹 Thread Size	
	20	20-20		25	20		20	
	25	25-25		32	25		25	
	32	32-32		40	32		32	
	40	40-40		50	40		40	
	50	50-50		63	50		50	

	螺纹 Thread Size			螺纹 Thread Size			螺纹 Thread Size	
	20	G1/2		25	G1/2		G1/2	
	25	G1/2		32	G1/2		G3/4	
	25	G3/4		40	G1/2		G1	
	32	G1		50	G1/2		G1-1/2	
	40	G1		63	G1/2		G1-3/4	
	50	G1-1/2					G2	

W系列净水管快速接头 W Series Water Adaptors

	WPC		管外径 × 螺纹 Tube OD × Thread Size			WPCF		管外径 × 螺纹 Tube OD × Thread Size			WPL		管外径 × 螺纹 Tube OD × Thread Size	
	4-M5	8-02	4-M5	8-02		4-M5	8-02	4-M5	8-02					
	4-01	8-03	4-01	8-03		4-01	8-03	4-01	8-03					
	4-02	8-04	4-02	8-04		4-02	8-04	4-02	8-04					
	6-M5	10-01	6-M5	10-01		6-M5	10-01	6-M5	10-01					
	6-01	10-02	6-01	10-02		6-01	10-02	6-01	10-02					
	6-02	10-03	6-02	10-03		6-02	10-03	6-02	10-03					
	6-03	10-04	6-03	10-04		6-03	10-04	6-03	10-04					
	6-04	12-01	6-04	12-01		6-04	12-01	6-04	12-01					
8-01	12-02	8-01	12-02	8-01	12-02	8-01	12-02							
	WPB		管外径 × 螺纹 Tube OD × Thread Size			WPD		管外径 × 螺纹 Tube OD × Thread Size			WPM		管外径 × 螺纹 Tube OD × Thread Size	
	4-M5	8-02	4-M5	8-02		4-M5	8-02	4-M5	8-02					
	4-01	8-03	4-01	8-03		4-01	8-03	4-01	8-03					
	4-02	8-04	4-02	8-04		4-02	8-04	4-02	8-04					
	6-M5	10-01	6-M5	10-01		6-M5	10-01	6-M5	10-01					
	6-01	10-02	6-01	10-02		6-01	10-02	6-01	10-02					
	6-02	10-03	6-02	10-03		6-02	10-03	6-02	10-03					
	6-03	10-04	6-03	10-04		6-03	10-04	6-03	10-04					
	6-04	12-01	6-04	12-01		6-04	12-01	6-04	12-01					
8-01	12-02	8-01	12-02	8-01	12-02	8-01	12-02							
	WPCJ		管外径 × 管外径 Tube OD × Tube OD			WPLJ		管外径 × 管外径 Tube OD × Tube OD			WPBJ		管外径 × 管外径 Tube OD × Tube OD	
		4-4		4-4			4-4		4-4					
		6-6		6-6			6-6		6-6					
		8-8		8-8			8-8		8-8					
		10-10		10-10			10-10		10-10					
		12-12		12-12			12-12		12-12					
		14-14		14-14			14-14		14-14					
	16-16		16-16		16-16		16-16							
	WPU		管外径 × 管外径 Tube OD × Tube OD			WPG		管外径 × 管外径 Tube OD × Tube OD			WPL		管外径 × 管外径 Tube OD × Tube OD	
		-4		-4			6-4	8-4			-4			
		-6		-6			8-6	10-6			-6			
		-8		-8			10-8	12-8			-8			
		-10		-10			12-10	14-10			-10			
		-12		-12			14-12	16-12			-12			
		-14		-14			16-14				-14			
	-16		-16					-16						
	WPN		管外径 × 管外径 Tube OD × Tube OD			WPY		管外径 × 管外径 Tube OD × Tube OD			WPW		管外径 × 管外径 Tube OD × Tube OD	
		6-4	8-4			-4		6-4			6-4			
		8-6	10-6			-6		8-6			8-6			
		10-8	12-8			-8		10-8			10-8			
		12-10	14-10			-10		12-10			12-10			
		14-12	16-12			-12		14-12			8-4			
						-14					10-6			
				-16				12-8						
	WPE		管外径 × 管外径 Tube OD × Tube OD			WBC		管外径 × 管外径 Tube OD × Tube OD			WUC		管外径 × 螺纹 Tube OD × Thread Size	
		-4		-4			-4		4-M5		8-02			
		-6		-6			-6		4-01		8-03			
		-8		-8			-8		4-02		8-04			
		-10		-10			-10		6-M5		10-01			
		-12		-12			-12		6-01		10-02			
		-14		-14			-14		6-02		10-03			
	-16		-16		-16		6-03	10-04						
								6-04	12-01					
								8-01	12-02					

F系列光纤透明接头 F Series Optical Fiber Transparent Fitting

	FPU		管外径 × 管外径 Tube OD × Tube OD			FPG		管外径 × 管外径 Tube OD × Tube OD			FZA		管外径 × 螺纹 Tube OD × Thread Size			FPF		管外径 × 管外径 Tube OD × Tube OD	
		03		03			05-03	14-12			05-01	12-01		03					
		04		04			05-04	16-10			05-02	12-02		04					
		05		05			07-05	16-12			06-01	12-03		05					
		06		06			08-03				06-02			06					
		07		07			08-05				07-01			07					
		08		08			10-07				07-02			08					
		10		10			10-08				08-01			10					
		12		12			12-07				08-02			12					
		14		14			12-10				10-01			14					
		16		16			14-10				10-02			16					

快拧接头 Fast Twist Fitting

KNPC	管内径 × 螺纹 Tube ID. × Thread Size		
	4-M5	6-04	12-01
4-01	8-01	12-02	
4-02	8-02	12-03	
4-03	8-03	12-04	
4-04	8-04	14-03	
6-M5	10-01	14-04	
6-01	10-02	16-03	
6-02	10-03	16-04	
6-03	10-04	16-06	

KNPCF	管内径 × 螺纹 Tube ID. × Thread Size		
	4-M5	6-04	12-01
4-01	8-01	12-02	
4-02	8-02	12-03	
4-03	8-03	12-04	
4-04	8-04	14-03	
6-M5	10-01	14-04	
6-01	10-02	16-03	
6-02	10-03	16-04	
6-03	10-04	16-06	

KNPL	管内径 × 螺纹 Tube ID. × Thread Size		
	4-M5	6-04	12-01
4-01	8-01	12-02	
4-02	8-02	12-03	
4-03	8-03	12-04	
4-04	8-04	14-03	
6-M5	10-01	14-04	
6-01	10-02	16-03	
6-02	10-03	16-04	
6-03	10-04	16-06	

KNPLF	管内径 × 螺纹 Tube ID. × Thread Size		
	4-M5	6-04	12-01
4-01	8-01	12-02	
4-02	8-02	12-03	
4-03	8-03	12-04	
4-04	8-04	14-03	
6-M5	10-01	14-04	
6-01	10-02	16-03	
6-02	10-03	16-04	
6-03	10-04	16-06	

KNPB	管内径 × 螺纹 Tube ID. × Thread Size		
	4-M5	6-04	12-01
4-01	8-01	12-02	
4-02	8-02	12-03	
4-03	8-03	12-04	
4-04	8-04	14-03	
6-M5	10-01	14-04	
6-01	10-02	16-03	
6-02	10-03	16-04	
6-03	10-04	16-06	

KNPD	管内径 × 螺纹 Tube ID. × Thread Size		
	4-M5	6-04	12-01
4-01	8-01	12-02	
4-02	8-02	12-03	
4-03	8-03	12-04	
4-04	8-04	14-03	
6-M5	10-01	14-04	
6-01	10-02	16-03	
6-02	10-03	16-04	
6-03	10-04	16-06	

KNPZB	管内径 × 螺纹 Tube ID. × Thread Size		
	4-M5	8-02	12-03
4-01	8-03	12-04	
4-02	8-04	14-03	
6-M5	10-01	14-04	
6-01	10-02	16-03	
6-02	10-03	16-04	
6-03	10-04	16-06	
6-04	12-01		
8-01	12-02		

KNPH	管内径 × 螺纹 Tube ID. × Thread Size		
	4-M5	8-02	12-03
4-01	8-03	12-04	
4-02	8-04	14-03	
6-M5	10-01	14-04	
6-01	10-02	16-03	
6-02	10-03	16-04	
6-03	10-04		
6-04	12-01		
8-01	12-02		

KNSL	管内径 × 螺纹 Tube ID. × Thread Size		
	4-M5	8-02	12-03
4-01	8-03	12-04	
4-02	8-04	14-03	
6-M5	10-01	14-04	
6-01	10-02	16-03	
6-02	10-03	16-04	
6-03	10-04		
6-04	12-01		
8-01	12-02		

KNSQ	管内径 × 螺纹 Tube ID. × Thread Size		
	4-M5	8-01	12-02
4-01	8-02	12-03	
4-02	8-03	12-04	
6-M5	8-04	14-03	
6-01	10-01	14-04	
6-02	10-02	16-03	
6-03	10-03	16-04	
6-04	10-04		

KNPM	管内径 × 管内径 Tube ID. × Tube ID.	
	4	
6		
8		
10		
12		
14		
16		

KNPU	管内径 × 管内径 Tube ID. × Tube ID.	
	4	
6		
8		
10		
12		
14		
16		

KNPG	管内径 × 管内径 Tube ID. × Tube ID.	
	4-6	
6-8		
8-10		
10-12		
12-14		
14-16		

KNPV	管内径 × 管内径 Tube ID. × Tube ID.	
	4	
6		
8		
10		
12		
14		
16		

KNPE	管内径 × 管内径 Tube ID. × Tube ID.	
	4	
6		
8		
10		
12		
14		
16		

KNPEND	管内径 × 管内径 Tube ID. × Tube ID.	
	6-4	12-10
8-4	14-8	
8-6	14-10	
10-4	14-12	
10-6	16-10	
10-8	16-12	
12-6	16-14	
12-8		

KNXL	管内径 × 管内径 Tube ID. × Tube ID.	
	4	
6		
8		
10		
12		
14		
16		

KNRPC	管内径 × 螺纹 Tube ID. × Thread Size		
	4-M5	8-01	12-01
4-01	8-02	12-02	
4-02	8-03	12-03	
6-M5	8-04	12-04	
6-01	10-01	14-03	
6-02	10-02	14-04	
6-03	10-03	16-03	
6-04	10-04	16-04	

KNRPL	管内径 × 螺纹 Tube ID. × Thread Size		
	4-M5	8-01	12-01
4-01	8-02	12-02	
4-02	8-03	12-03	
6-M5	8-04	12-04	
6-01	10-01	14-03	
6-02	10-02	14-04	
6-03	10-03	16-03	
6-04	10-04	16-04	

KNRPB	管内径 × 螺纹 Tube ID. × Thread Size		
	4-M5	8-01	12-01
4-01	8-02	12-02	
4-02	8-03	12-03	
6-M5	8-04	12-04	
6-01	10-01	14-03	
6-02	10-02	14-04	
6-03	10-03	16-03	
6-04	10-04	16-04	

KNRPD	管内径 × 螺纹 Tube ID. × Thread Size		
	4-M5	8-01	12-01
4-01	8-02	12-02	
4-02	8-03	12-03	
6-M5	8-04	12-04	
6-01	10-01	14-03	
6-02	10-02	14-04	
6-03	10-03	16-03	
6-04	10-04	16-04	

KNRPH	管内径 × 螺纹 Tube ID × Thread Size		
	4-M5	8-01	12-01
4-01	8-02	12-02	
4-02	8-03	12-03	
6-M5	8-04	12-04	
6-01	10-01	14-03	
6-02	10-02	14-04	
6-03	10-03	16-03	
6-04	10-04	16-04	

KNRPH(2)	管内径 × 螺纹 Tube ID × Thread Size		
	4-M5	8-01	12-01
4-01	8-02	12-02	
4-02	8-03	12-03	
6-M5	8-04	12-04	
6-01	10-01	14-03	
6-02	10-02	14-04	
6-03	10-03	16-03	
6-04	10-04	16-04	

KNRPH(3)	管内径 × 螺纹 Tube ID × Thread Size		
	4-M5	8-01	12-01
4-01	8-02	12-02	
4-02	8-03	12-03	
6-M5	8-04	12-04	
6-01	10-01	14-03	
6-02	10-02	14-04	
6-03	10-03	16-03	
6-04	10-04	16-04	

KNRPV	管内径 × 管内径 Tube ID × Tube ID	
	-4	
-6		
-8		
-10		
-12		
-14		
-16		

KNRPE	管内径 × 管内径 Tube ID × Tube ID	
	-4	
-6		
-8		
-10		
-12		
-14		
-16		

KNRPXL	管内径 × 管内径 Tube ID × Tube ID	
	-4	
-6		
-8		
-10		
-12		
-14		
-16		

卡套接头 Ferrule Fitting

KTPC	管外径 × 螺纹 Tube OD × Thread Size		
	4-01	8-04	14-03
4-02	10-01	14-04	
6-01	10-02	16-04	
6-02	10-03	16-06	
6-03	10-04		
6-04	12-02		
8-01	12-03		
8-02	12-04		
8-03	14-02		

KTPCF	管外径 × 螺纹 Tube OD × Thread Size		
	4-01	8-04	14-04
4-02	10-01	16-03	
6-01	10-02	16-04	
6-02	10-03	16-06	
6-03	10-04		
6-04	12-02		
8-01	12-03		
8-02	12-04		
8-03	14-03		

KTPL	管外径 × 螺纹 Tube OD × Thread Size		
	4-01	8-04	14-04
4-02	10-01	16-03	
6-01	10-02	16-04	
6-02	10-03	16-06	
6-03	10-04		
6-04	12-02		
8-01	12-03		
8-02	12-04		
8-03	14-03		

KTPLF	管外径 × 螺纹 Tube OD × Thread Size		
	4-01	8-03	12-04
4-02	8-04	14-03	
6-01	10-01	14-04	
6-02	10-02	16-03	
6-03	10-03	16-04	
6-04	10-04	16-06	
8-01	12-02		
8-02	12-03		

KTPB	管外径 × 螺纹 Tube OD × Thread Size		
	4-01	8-03	12-04
4-02	8-04	14-03	
6-01	10-01	14-04	
6-02	10-02	16-03	
6-03	10-03	16-04	
6-04	10-04	16-06	
8-01	12-02		
8-02	12-03		

KTPD	管外径 × 螺纹 Tube OD × Thread Size		
	4-01	8-03	12-04
4-02	8-04	14-03	
6-01	10-01	14-04	
6-02	10-02	16-03	
6-03	10-03	16-04	
6-04	10-04	16-06	
8-01	12-02		
8-02	12-03		

KTPU	管外径 × 管外径 Tube OD × Tube OD	
	4	
6		
8		
10		
12		
14		
16		

KTPG	管外径 × 管外径 Tube OD × Tube OD	
	6-4	
8-4		
8-6		
10-6		
10-8		
12-8		
12-10		
14-12		
16-12		

KTPM	管外径 × 管外径 Tube OD × Tube OD	
	4	
6		
8		
10		
12		
14		
16		

KTPH	管外径 × 螺纹 Tube OD × Thread Size		
	4-M5	8-01	12-01
4-01	8-02	12-02	
4-02	8-03	12-03	
6-M5	8-04	12-04	
6-01	10-01	14-03	
6-02	10-02	14-04	
6-03	10-03	16-03	
6-04	10-04	16-04	

KTSL	管外径 × 螺纹 Tube OD × Thread Size		
	4-M5	8-01	12-01
4-01	8-02	12-02	
4-02	8-03	12-03	
6-M5	8-04	12-04	
6-01	10-01	14-03	
6-02	10-02	14-04	
6-03	10-03	16-03	
6-04	10-04	16-04	



KTPV	管外径 × 管外径 Tube OD × Tube OD	
	4	
6		
8		
10		
12		
14		
16		



KTPN	管外径 × 管外径 Tube OD × Tube OD	
	6-4	
8-4		
8-6		
10-6		
10-8		
12-8		
12-10		
14-12		
16-12		



KTPE	管外径 × 管外径 Tube OD × Tube OD	
	4	
6		
8		
10		
12		
14		
16		



KTPXL	管外径 × 管外径 Tube OD × Tube OD	
	4	
6		
8		
10		
12		
14		
16		

C式快速接头(锌合金) C Type Quick Couplers(Zinc Alloy)

	型号 Model	接管尺寸 Port size		型号 Model	接管尺寸 Port size		型号 Model	接管尺寸 Port size
	-10	PT1/8		-10	PT1/8		-10	6×4
	-20	PT1/4		-20	PT1/4		-20	8×5
	-30	PT3/8		-30	PT3/8		-30	10×6.5
	-40	PT1/2		-40	PT1/2		-40	12×8



	型号 Model	接管尺寸 Port size		型号 Model	接管尺寸 Port size		型号 Model	接管尺寸 Port size
	-10	6×4		-10	PT1/8		-10	PT1/8
	-20	8×5		-20	PT1/4		-20	PT1/4
	-30	10×6.5		-30	PT3/8		-30	PT3/8
	-40	12×8		-40	PT1/2		-40	PT1/2



	型号 Model	接管尺寸 Port size		型号 Model	接管尺寸 Port size		型号 Model	接管尺寸 Port size
	-10	6×4		-10	6×4		-10	PT1/8
	-20	8×5		-20	8×5		-20	PT1/4
	-30	10×6.5		-30	10×6.5		-30	PT3/8
	-40	12×8		-40	12×8		-40	PT1/2



	型号 Model	接管尺寸 Port size		型号 Model	接管尺寸 Port size		型号 Model	接管尺寸 Port size
	-10	PT1/8		-10	6×4		-10	6×4
	-20	PT1/4		-20	8×5		-20	8×5
	-30	PT3/8		-30	10×6.5		-30	10×6.5
	-40	PT1/2		-40	12×8		-40	12×8

	型号 Model	接管尺寸 Port size		型号 Model	接管尺寸 Port size		型号 Model	接管尺寸 Port size
	SMV	2		SMY	3		SML	2
							SMT	3
							SMM	4
							SMX	5

C式快速接头(全铜) C Type Quick Couplers(Brass)

	管内径 Tube ID		螺纹 Thread Size		螺纹 Thread Size
	4		1/8		
	6		1/4		
	8		3/8		
	10		1/2		
	12		3/4		

	管内径 Tube ID		螺纹 Thread Size		螺纹 Thread Size
	4		1/8		
	6		1/4		
	8		3/8		
	10		1/2		
	12		3/4		

	管外径 Tube OD		管内径 Tube ID		管外径 Tube OD
	4		4		
	6		6		
	8		8		
	10		10		
	12		12		

C式自锁式接头(铝合金) C Type Self Lock Couplers (Aluminium Alloy)



	型号 Model	接管尺寸 Port size		型号 Model	接管尺寸 Port size		型号 Model	接管尺寸 Port size
	-10	PT1/8		-10	PT1/8		-10	6×4
	-20	PT1/4		-20	PT1/4		-20	8×5
	-30	PT3/8		-30	PT3/8		-30	10×6.5
	-40	PT1/2		-40	PT1/2		-40	12×8



	型号 Model	接管尺寸 Port size		型号 Model	接管尺寸 Port size		型号 Model	接管尺寸 Port size
	-10	6×4		-10	PT1/8		-10	PT1/8
	-20	8×5		-20	PT1/4		-20	PT1/4
	-30	10×6.5		-30	PT3/8		-30	PT3/8
	-40	12×8		-40	PT1/2		-40	PT1/2



	型号 Model	接管尺寸 Port size		型号 Model	接管尺寸 Port size		型号 Model	位数 Stations
	-10	6×4		-10	6×4		LSMV	2
	-20	8×5		-20	8×5			
	-30	10×6.5		-30	10×6.5			
	-40	12×8		-40	12×8			

	型号 Model	位数 Stations		型号 Model	位数 Stations		型号 Model	位数 Stations
	LSMY	3		LSML	2		AL-2	2
				LSMT	3		AL-3	3
				LSMM	4		AL-4	4
				LSMX	5		AL-5	5

C式快速接头(塑料) C Type Quick Couplers (Plastic)

	型号 Model	接管尺寸 Port size		型号 Model	接管尺寸 Port size		型号 Model	接管尺寸 Port size
	-10	PT1/8		-10	PT1/8		-10	6×4
	-20	PT1/4		-20	PT1/4		-20	8×5
	-30	PT3/8		-30	PT3/8		-30	10×6.5
	-40	PT1/2		-40	PT1/2		-40	12×8

	型号 Model	接管尺寸 Port size		型号 Model	接管尺寸 Port size		型号 Model	接管尺寸 Port size
	-10	6×4		-10	PT1/8		-10	PT1/8
	-20	8×5		-20	PT1/4		-20	PT1/4
	-30	10×6.5		-30	PT3/8		-30	PT3/8
	-40	12×8		-40	PT1/2		-40	PT1/2

	型号 Model	接管尺寸 Port size		型号 Model	接管尺寸 Port size		型号 Model	接管尺寸 Port size
	-10	6×4		-10	6×4		-10	6×4
	-20	8×5		-20	8×5		-20	8×5
	-30	10×6.5		-30	10×6.5		-30	10×6.5
	-40	12×8		-40	12×8		-40	12×8

公制304/316不锈钢快插接头 Meter Type 304/316 Stainless Steel One Touch Fitting

SPC	8	-	02
系列号 Series	管外径 Tube OD.		螺纹 Thread

英制304/316不锈钢插接头 Inch Type 304/316 Stainless Steel One Touch Fitting

SPC	3/8	-	NPT02
系列号 Series	管外径 Tube OD.		螺纹 Thread

技术参数 Specification

主要材质 Main Material	304/316不锈钢 304/316 Stainless Steel
最高耐压力 Proof Pressure	1.32Mpa
使用压力范围 Pressure Range	0~0.9Mpa
环境及流体温度 Ambient & Fluid Temp.	0~60℃
可配接管类别 Applicable Tube Type	PU软管、PE软管等 PU Tube, PE Tube, etc.
可配接管尺寸 Applicable Tube Size	公制插管、英制插管 Meter Tube, Inch Tube
可配螺纹 Applicable Thread	M、G、PT、NPT、UNI、UNF螺纹等 M、G、PT、NPT、UNI、UNF Thread, etc.

SPC 	管外径 × 螺纹 Tube OD. × Thread Size		
	4-M5	6-04	12-02
	4-M6	8-01	12-03
	4-01	8-02	12-04
	4-02	8-03	14-02
	6-M5	8-04	14-03
	6-M6	10-01	14-04
	6-01	10-02	16-02
	6-02	10-03	16-03
	6-03	10-04	16-04

SPOC 	管外径 × 螺纹 Tube OD. × Thread Size		
	4-M5	6-04	12-02
	4-M6	8-01	12-03
	4-01	8-02	12-04
	4-02	8-03	14-02
	6-M5	8-04	14-03
	6-M6	10-01	14-04
	6-01	10-02	16-02
	6-02	10-03	16-03
	6-03	10-04	16-04

SPCF 	管外径 × 螺纹 Tube OD. × Thread Size		
	4-M5	6-04	12-02
	4-M6	8-01	12-03
	4-01	8-02	12-04
	4-02	8-03	14-02
	6-M5	8-04	14-03
	6-M6	10-01	14-04
	6-01	10-02	16-02
	6-02	10-03	16-03
	6-03	10-04	16-04

SPL 	管外径 × 螺纹 Tube OD. × Thread Size		
	4-M5	6-04	12-02
	4-M6	8-01	12-03
	4-01	8-02	12-04
	4-02	8-03	14-02
	6-M5	8-04	14-03
	6-M6	10-01	14-04
	6-01	10-02	16-02
	6-02	10-03	16-03
	6-03	10-04	16-04

SPLF 	管外径 × 螺纹 Tube OD. × Thread Size		
	4-M5	6-04	12-02
	4-M6	8-01	12-03
	4-01	8-02	12-04
	4-02	8-03	14-02
	6-M5	8-04	14-03
	6-M6	10-01	14-04
	6-01	10-02	16-02
	6-02	10-03	16-03
	6-03	10-04	16-04

SPB 	管外径 × 螺纹 Tube OD. × Thread Size		
	4-M5	6-04	12-02
	4-M6	8-01	12-03
	4-01	8-02	12-04
	4-02	8-03	14-02
	6-M5	8-04	14-03
	6-M6	10-01	14-04
	6-01	10-02	16-02
	6-02	10-03	16-03
	6-03	10-04	16-04

SPD 	管外径 × 螺纹 Tube OD. × Thread Size		
	4-M5	6-04	12-02
	4-M6	8-01	12-03
	4-01	8-02	12-04
	4-02	8-03	14-02
	6-M5	8-04	14-03
	6-M6	10-01	14-04
	6-01	10-02	16-02
	6-02	10-03	16-03
	6-03	10-04	16-04

SPX 	管外径 × 螺纹 Tube OD. × Thread Size		
	4-M5	6-04	12-02
	4-M6	8-01	12-03
	4-01	8-02	12-04
	4-02	8-03	14-02
	6-M5	8-04	14-03
	6-M6	10-01	14-04
	6-01	10-02	16-02
	6-02	10-03	16-03
	6-03	10-04	16-04

SPMF 	管外径 × 螺纹 Tube OD. × Thread Size		
	4-01	8-04	14-03
	4-02	10-01	14-04
	6-01	10-02	16-02
	6-02	10-03	16-03
	6-03	10-04	16-04
	6-04	12-02	-
	8-01	12-03	-
	8-02	12-04	-
	8-03	14-02	-

SSL 	管外径 × 螺纹 tube dia. × thread size		
	4-M5	6-04	12-02
	4-M6	8-01	12-03
	4-01	8-02	12-04
	4-02	8-03	14-02
	6-M5	8-04	14-03
	6-M6	10-01	14-04
	6-01	10-02	16-02
	6-02	10-03	16-03
	6-03	10-04	16-04

SPM 	管外径 × 管外径 Tube OD. × Tube OD.	
	4	
	6	
	8	
	10	
	12	
	14	
	16	

SPMU 	管外径 × 管外径 Tube OD. × Tube OD.		
	4-M5	8-02	12-03
	4-01	8-03	12-04
	4-02	8-04	14-02
	6-M5	10-01	14-03
	6-01	10-02	14-04
	6-02	10-03	16-02
	6-03	10-04	16-03
	6-04	12-01	16-04
	8-01	12-02	16-06

SPU 	管外径 × 管外径 Tube OD. × Tube OD.	
	4	
	6	
	8	
	10	
	12	
	14	
	16	

SPG 	管外径 × 管外径 Tube OD. × Tube OD.	
	4-6	8-14
	4-8	8-16
	4-10	10-12
	6-8	10-14
	6-10	10-16
	6-12	12-14
	6-14	12-16
	8-10	14-16
	8-12	-

SPV 	管外径 × 管外径 Tube OD. × Tube OD.	
	4	
	6	
	8	
	10	
	12	
	14	
	16	

SPE 	管外径 × 管外径 Tube OD. × Tube OD.	
	4	
	6	
	8	
	10	
	12	
	14	
	16	

SPEND 	管外径 × 管外径 Tube OD. × Tube OD.	
	6-4	14-10
	8-4	16-10
	8-6	14-12
	10-6	16-12
	12-6	16-14
	10-8	-
	12-8	-
	14-8	-
	12-10	-

SPXL 	管外径 × 管外径 Tube OD. × Tube OD.	
	4	
	6	
	8	
	10	
	12	
	14	
	16	

公制全铜快插接头 Meter Type Brass One Touch Fitting 技术参数 Specification

BPC **8** - **02**
系列号 管外径 螺纹
Series Tube OD. Thread

主要材质 Main Material	铜 Brass
最高耐压力 Proof Pressure	1.32Mpa
使用压力范围 Pressure Range	0~0.9Mpa
环境及流体温度 Ambient & Fluid Temp.	0~60℃
可配插管类别 Applicable Tube Type	PU软管、PE软管等 PU Tube, PE Tube, etc.
可配插管尺寸 Applicable Tube Size	公制插管、英制插管 Meter Tube, Inch Tube
可配螺纹 Applicable Thread	M、G、PT、NPT、UNI、UNF螺纹等 M、G、PT、NPT、UNI、UNF Thread, etc.

英制全铜快插接头 Inch Type Brass One Touch Fitting

BPC **3/8** - **NPT02**
系列号 管外径 螺纹
Series Tube OD. Thread

BPC	管外径 × 螺纹 Tube OD. × Thread Size		
		4-M5	8-02
	4-01	8-03	12-04
	4-02	8-04	14-02
	6-M5	10-01	14-03
	6-01	10-02	14-04
	6-02	10-03	16-02
	6-03	10-04	16-03
	6-04	12-01	16-04
	8-01	12-02	16-06

BPOC	管外径 × 螺纹 Tube OD. × Thread Size		
		4-M5	8-02
	4-01	8-03	12-04
	4-02	8-04	14-02
	6-M5	10-01	14-03
	6-01	10-02	14-04
	6-02	10-03	16-02
	6-03	10-04	16-03
	6-04	12-01	16-04
	8-01	12-02	16-06

BPCF	管外径 × 螺纹 Tube OD. × Thread Size		
		4-M5	8-02
	4-01	8-03	12-04
	4-02	8-04	14-02
	6-M5	10-01	14-03
	6-01	10-02	14-04
	6-02	10-03	16-02
	6-03	10-04	16-03
	6-04	12-01	16-04
	8-01	12-02	16-06

BPL	管外径 × 螺纹 Tube OD. × Thread Size		
		4-M5	8-02
	4-01	8-03	12-04
	4-02	8-04	14-02
	6-M5	10-01	14-03
	6-01	10-02	14-04
	6-02	10-03	16-02
	6-03	10-04	16-03
	6-04	12-01	16-04
	8-01	12-02	16-06

BPLL	管外径 × 螺纹 Tube OD. × Thread Size		
		4-M5	12-03
	4-01	12-04	14-03
	4-02	14-03	14-04
	6-M5	14-04	16-03
	6-01	16-03	16-04
	6-02	16-04	
	6-03		
	6-04		
	8-01		

BPLF	管外径 × 螺纹 Tube OD. × Thread Size		
		4-M5	8-02
	4-01	8-03	12-04
	4-02	8-04	14-02
	6-M5	10-01	14-03
	6-01	10-02	14-04
	6-02	10-03	16-02
	6-03	10-04	16-03
	6-04	12-01	16-04
	8-01	12-02	16-06

BPB	管外径 × 螺纹 Tube OD. × Thread Size		
		4-M5	8-02
	4-01	8-03	12-04
	4-02	8-04	14-02
	6-M5	10-01	14-03
	6-01	10-02	14-04
	6-02	10-03	16-02
	6-03	10-04	16-03
	6-04	12-01	16-04
	8-01	12-02	16-06

BPD	管外径 × 螺纹 Tube OD. × Thread Size		
		4-M5	8-02
	4-01	8-03	12-04
	4-02	8-04	14-02
	6-M5	10-01	14-03
	6-01	10-02	14-04
	6-02	10-03	16-02
	6-03	10-04	16-03
	6-04	12-01	16-04
	8-01	12-02	16-06

BPX	管外径 × 螺纹 Tube OD. × Thread Size		
		4-M5	8-02
	4-01	8-03	12-04
	4-02	8-04	14-02
	6-M5	10-01	14-03
	6-01	10-02	14-04
	6-02	10-03	16-02
	6-03	10-04	16-03
	6-04	12-01	16-04
	8-01	12-02	16-06

BPMF	管外径 × 螺纹 Tube OD. × Thread Size		
		4-M5	8-01
	4-01	8-02	12-04
	4-02	8-03	14-03
	4-03	8-04	14-04
	6-M5	10-01	16-03
	6-01	10-02	16-04
	6-02	10-03	
	6-03	10-04	
	6-04	12-02	

BPH	管外径 × 螺纹 Tube OD. × Thread Size		
		4-M5	8-02
	4-01	8-03	12-04
	4-02	8-04	14-03
	6-M5	10-01	14-04
	6-01	10-02	16-03
	6-02	10-03	16-04
	6-03	10-04	
	6-04	12-01	
	8-01	12-02	

BPZR	管外径 × 螺纹 Tube OD. × Thread Size		
		4-M5	8-02
	4-01	8-03	12-04
	4-02	8-04	
	6-M5	10-01	
	6-01	10-02	
	6-02	10-03	
	6-03	10-04	
	6-04	12-01	
	8-01	12-02	

BSL	管外径 × 螺纹 Tube OD. × Thread Size		
		4-M5	8-02
	4-01	8-03	14-03
	4-02	8-04	14-04
	6-M5	10-01	16-03
	6-01	10-02	16-04
	6-02	10-03	
	6-03	10-04	
	6-04	12-02	
	8-01	12-03	

BSQ	管外径 × 螺纹 Tube OD. × Thread Size		
		4-M5	8-02
	4-01	8-03	14-03
	4-02	8-04	14-04
	6-M5	10-01	16-03
	6-01	10-02	16-04
	6-02	10-03	
	6-03	10-04	
	6-04	12-02	
	8-01	12-03	

BFQ	螺纹 × 螺纹 Thread Size × Thread Size	
		01-M5
	01-01	03-03
	01-02	03-04
	01-03	04-03
	01-04	04-04
	02-01	
	02-02	
	02-03	
	02-04	

BPU	管外径 × 管外径 Tube OD. × Tube OD.	
		4
	6	
	8	
	10	
	12	
	14	
	16	

BPG	管外径 × 管外径 Tube OD. × Tube OD.	
		6-4
	8-4	16-14
	8-6	
	10-6	
	10-8	
	12-8	
	12-10	
	14-10	
	14-12	

BPV	管外径 × 管外径 Tube OD. × Tube OD.	
		4
	6	
	8	
	10	
	12	
	14	
	16	

BPE	管外径 × 管外径 Tube OD × Tube OD	
		4
	6	
	8	
	10	
	12	
	14	
	16	

BPEG	管外径 × 管外径 Tube OD × Tube OD	
		6-4
	8-4	14-8
	8-6	14-10
	10-4	14-12
	10-6	16-10
	10-8	16-12
	12-6	16-14
	12-8	

BPZA	管外径 × 管外径 Tube OD × Tube OD	
		4
	6	
	8	
	10	
	12	
	14	
	16	

BPY	管外径 × 管外径 Tube OD × Tube OD	
		4
	6	
	8	
	10	
	12	
	14	
	16	

BPW	管外径 × 管外径 Tube OD × Tube OD	
		6-4
	8-4	14-12
	8-6	16-12
	10-6	16-14
	10-8	
	12-6	
	12-8	
	12-10	

BPM	管外径 × 螺纹 Tube OD × Thread Size	
		4
	6	
	8	
	10	
	12	
	14	
	16	

SCQ系列球阀 SCQ Series Ball Valve

SCQ-01	螺纹 × 螺纹 Thread Size × Thread Size	
		1/8
	1/4	
	3/8	
	1/2	
	3/4	
	1"	

SCQ-02	螺纹 × 螺纹 Thread Size × Thread Size	
		1/8
	1/4	
	3/8	
	1/2	
	3/4	
	1"	

SCQ-03	螺纹 × 螺纹 Thread Size × Thread Size	
		1/8
	1/4	
	3/8	
	1/2	
	3/4	
	1"	

SCQ-04	管内径 × 螺纹 Tube ID × Thread Size	
		6-1/4
	8-1/4	
	10-1/4	
	8-3/8	
	10-3/8	
	8-1/2	
	10-1/2	
	12-1/2	

SCQ-05	管内径 × 螺纹 Tube ID × Thread Size	
		6-1/4
	8-1/4	
	10-1/4	
	8-3/8	
	10-3/8	
	8-1/2	
	10-1/2	

SCQ-06	管内径 × 管内径 Tube ID × Tube ID	
		φ4
	φ6	
	φ8	
	φ10	
	φ12	
	φ14	
	φ16	

SCQ-07	螺纹 × 螺纹 Thread Size × Thread Size	
		1/8
	1/4	
	3/8	
	1/2	
	3/4	
	1	

SCQ-08	管内径 × 螺纹 Tube ID × Thread Size	
		4-01
	4-02	
	4-03	
	6-01	
	6-02	
	6-03	
	8-01	
	8-02	
	8-03	

SCQ-09	管内径 × 管内径 Tube ID × Tube ID	
		φ4
	φ6	
	φ8	
	φ10	
	φ12	
	φ14	
	φ16	

SCQ-10	管外径 × 管外径 Tube OD × Tube OD	
		φ4
	φ6	
	φ8	
	φ10	
	φ12	
	φ14	
	φ16	

SCQ-11	螺纹 × 螺纹 Thread Size × Thread Size	
		1/8
	1/4	
	3/8	
	1/2	
	3/4	
	1	



















SCQ-12	螺纹 × 螺纹 Thread Size × Thread Size	
		1/8
	1/4	
	3/8	
	1/2	
	3/4	
	1	

SCQ-13	管内径 × 螺纹 Tube ID × Thread Size	
		6-1/4
	8-1/4	
	10-1/4	
	8-3/8	
	10-3/8	
	8-1/2	
	10-1/2	
	12-1/2	

SCQ-14	管外径 × 管外径 Tube OD × Tube OD	
		φ4
	φ6	
	φ8	
	φ10	
	φ12	
	φ14	
	φ16	

SCQ-15	螺纹 × 螺纹 Thread Size × Thread Size	
		1/8
	1/4	
	3/8	
	1/2	
	3/4	
	1	

消声器 Silencers

<p>AN</p> 	<p>型号 Model</p> <ul style="list-style-type: none"> AN-M5 AN-01 AN-02 AN-03 AN-04 AN-06 AN-08 AN-10 	<p>PSL</p> 	<p>型号 Model</p> <ul style="list-style-type: none"> PSL-M5 PSL-01 PSL-02 PSL-03 PSL-04 PSL-06 PSL-08 PSL-10 	<p>PSU</p> 	<p>型号 Model</p> <ul style="list-style-type: none"> PSU-M5 PSU-01 PSU-02 PSU-03 PSU-04 PSU-06 PSU-08 PSU-10
<p>BSLM</p> 	<p>型号 Model</p> <ul style="list-style-type: none"> BSLM-M5 BSLM-01 BSLM-02 BSLM-03 BSLM-04 BSLM-06 BSLM-08 BSLM-10 	<p>BSL</p> 	<p>型号 Model</p> <ul style="list-style-type: none"> BSL-M5 BSL-01 BSL-02 BSL-03 BSL-04 BSL-06 BSL-08 BSL-10 	<p>PSC</p> 	<p>型号 Model</p> <ul style="list-style-type: none"> PSC-M5 PSC-01 PSC-02 PSC-03 PSC-04 PSC-06 PSC-08 PSC-10
<p>BESL</p> 	<p>型号 Model</p> <ul style="list-style-type: none"> BESL-M5 BESL-01 BESL-02 BESL-03 BESL-04 BESL-06 BESL-08 BESL-10 	<p>PSS</p> 	<p>型号 Model</p> <ul style="list-style-type: none"> PSS-M5 PSS-01 PSS-02 PSS-03 PSS-04 PSS-06 PSS-08 PSS-10 	<p>PSF</p> 	<p>型号 Model</p> <ul style="list-style-type: none"> PSF-01 PSF-02 PSF-03 PSF-04 PSF-06 PSF-08 PSF-10 PSF-12
<p>ASLM</p> 	<p>型号 Model</p> <ul style="list-style-type: none"> ASLM-M5 ASLM-01 ASLM-02 ASLM-03 ASLM-04 ASLM-06 ASLM-08 ASLM-10 	<p>SSLM</p> 	<p>型号 Model</p> <ul style="list-style-type: none"> SSLM-M5 SSLM-01 SSLM-02 SSLM-03 SSLM-04 SSLM-06 SSLM-08 SSLM-10 	<p>TSLM</p> 	<p>型号 Model</p> <ul style="list-style-type: none"> TSLM-M5 TSLM-01 TSLM-02 TSLM-03 TSLM-04 TSLM-06 TSLM-08 TSLM-10
<p>USLM</p> 	<p>型号 Model</p> <ul style="list-style-type: none"> USLM-M5 USLM-01 USLM-02 USLM-03 USLM-04 USLM-06 USLM-08 USLM-10 	<p>ABSL</p> 	<p>型号 Model</p> <ul style="list-style-type: none"> ABSL-M5 ABSL-01 ABSL-02 ABSL-03 ABSL-04 ABSL-06 ABSL-08 ABSL-10 	<p>SBSL</p> 	<p>型号 Model</p> <ul style="list-style-type: none"> SBSL-01 SBSL-02 SBSL-03 SBSL-04 SBSL-06 SBSL-08
<p>SAN</p> 	<p>型号 Model</p> <ul style="list-style-type: none"> SAN-M5 SAN-01 SAN-02 SAN-03 SAN-04 SAN-06 SAN-08 SAN-10 	<p>BSC</p> 	<p>型号 Model</p> <ul style="list-style-type: none"> BSC-M5 BSC-01 BSC-02 BSC-03 BSC-04 BSC-06 BSC-08 BSC-10 	<p>DSC</p> 	<p>型号 Model</p> <ul style="list-style-type: none"> DSC-M5 DSC-01 DSC-02 DSC-03 DSC-04 DSC-06 DSC-08 DSC-10
<p>A</p> 	<p>型号 Model</p> <ul style="list-style-type: none"> A-M5 A-01 A-02 A-03 A-04 A-06 A-08 A-10 	<p>B</p> 	<p>型号 Model</p> <ul style="list-style-type: none"> B-01 B-02 B-03 B-04 B-06 B-08 B-10 	<p>C</p> 	<p>型号 Model</p> <ul style="list-style-type: none"> C-4 C-6 C-8 C-10 C-12 C-14 C-16

D	型号 Model
	D-4
	D-6
	D-8
	D-10
	D-12
	D-14
	D-16

E	型号 Model
	E-M5
	E-01
	E-02
	E-03
	E-04
	E-06
	E-08

F	型号 Model
	F-01
	F-02
	F-03
	F-04
	F-06
	F-08

G	型号 Model
	G-01
	G-02
	G-03
	G-04
	G-06
	G-08

H	型号 Model
	H-01
	H-02
	H-03
	H-04
	H-06
	H-08



I	型号 Model
	I-01
	I-02
	I-03
	I-04
	I-06
	I-08

J	型号 Model
	J-01
	J-02
	J-03
	J-04
	J-06
	J-08

K	型号 Model
	K-01
	K-02
	K-03
	K-04
	K-06
	K-08

L	型号 Model
	L-4
	L-6
	L-8
	L-10
	L-12
	L-14

ARTS系列吹尘枪
ARTS Serise Air Gun

型号 Model	颜色 Colour
	ARTS Red 红
	ARTS Blue 蓝
	ARTS Yellow 黄
	ARTSL Red 红
	ARTSL Blue 蓝
	ARTSL Yellow 黄

BRTS系列吹尘枪
BRTS Serise Air Gun

型号 Model	颜色 Colour
	BRTS Red 红
	BRTS Blue 蓝
	BRTS Yellow 黄
	BRTSL Red 红
	BRTSL Blue 蓝
	BRTSL Yellow 黄

DG系列吹尘枪
DG Serise Air Gun

型号 Model	
	DG-10

KT-B 系列可调吹尘枪
KT-B Serise Adjustable Air Gun

型号 Model	
	KT-B

989系列吹尘枪
989 Series Air Gun

型号 Model	
	989
	989-1
	989-2
	989-3

GT系列冲气枪
GT Series Air Punching Gun

型号 Model	
	GT-1:黑色气管Black Tube
	GT-2:蓝色气管Blue Tube
	GT-3:防震压力表款 Shockproof Pressure Gauge Type
	GT-4:电子压力表款 Electronic Pressure Gauge Type

TK系列气管剪
TK Series Tube Cutter

型号 Model	
	TK-1
	TK-2
	TK-3

TC系列气管剪
TC Series Tube Cutter

型号 Model	
	TC-1
	TC-2
	TC-3

HS系列气动剪
HS Series Pneumatic Cutter

型号 Model	
	HS-3K
	HS-5K
	HS-10A
	HS-20K
	HS-30K

TSK系列气管卡
TSK Series Tube Strap

型号 Model	
	TSK-4
	TSK-6
	TSK-8
	TSK-10
	TSK-12

TC系列气管卡
TC Series Tube Tube Strap

型号 Model		
	6-12	18-29
	9-16	22-32
	10-16	25-38
	13-19	32-44
	16-25	

AHR系列自动伸缩式卷管器
AHR Series Auto Hose Reel

型号 Model			
	4×2.5	10×8	16×13
	6×4	12×8	
	8×5	12×10	
	8×6	14×10	
	10×6.5	16×12	

PU系列PU软管 PU Series PU Tube

Operating Pressure: 使用压力:0~0.8Mpa	公制型	公制管外径	公制管内径	英制型	英制管外径	英制管内径	标准长度	颜色	使用温度
	Meter Type	Tube Meter O.D.	Tube Meter I.D.	Inch Type	Tube Inch O.D.	Tube Inch I.D.	Standard Length	Colour	Operating Temperature
	PU4X2.5	4mm	2.5mm	PU1/8	3.175mm	-	200M	蓝,黑,橙,红,黄,白色,透明,透明蓝	-20~60℃
	PU6X4	6mm	4mm	PU5/32	3.969mm	-	200M		
	PU8X5	8mm	5mm	PU3/16	4.762mm	-	100M		
	PU8X6	8mm	6mm	PU1/4	6.35mm	-	100M		
	PU10X6.5	10mm	6.5mm	PU5/16	7.938mm	-	100M		
	PU10X8	10mm	8mm	PU3/8	9.525mm	-	100M		
	PU12X8	12mm	8mm	PU1/2	12.7mm	-	100M		
	PU12X10	12mm	10mm	PU5/8	15.87mm	-	100M		
	PU14X10	14mm	10mm	PU3/4	19.05mm	-	50M		
	PU16X12	16mm	12mm	PU1	25.4mm	-	50M		
	PU16X13	16mm	13mm	PU1-1/4	31.75mm	-	50M		

PUA系列阻燃管 PUA Series Fire Retardant Tube

Operating Pressure: 使用压力:0~1.8Mpa	公制型	公制管外径	公制管内径	英制型	英制管外径	英制管内径	标准长度	颜色	使用温度
	Meter Type	Tube Meter O.D.	Tube Meter I.D.	Inch Type	Tube Inch O.D.	Tube Inch I.D.	Standard Length	Colour	Operating Temperature
	PUA4X2.5	4mm	2.5mm	PUA1/8	3.175mm	-	200M	蓝,黑,橙,红,黄,白色,透明,透明蓝	-20~60℃
	PUA6X4	6mm	4mm	PUA5/32	3.969mm	-	200M		
	PUA8X5	8mm	5mm	PUA3/16	4.762mm	-	100M		
	PUA8X6	8mm	6mm	PUA1/4	6.35mm	-	100M		
	PUA10X6.5	10mm	6.5mm	PUA5/16	7.938mm	-	100M		
	PUA10X8	10mm	8mm	PUA3/8	9.525mm	-	100M		
	PUA12X8	12mm	8mm	PUA1/2	12.7mm	-	100M		
	PUA12X10	12mm	10mm	PUA5/8	15.87mm	-	100M		
	PUA14X10	14mm	10mm	PUA3/4	19.05mm	-	50M		
	PUA16X12	16mm	12mm	PUA1	25.4mm	-	50M		
	PUA16X13	16mm	13mm	PUA1-1/4	31.75mm	-	50M		

PUB系列PU包纱管 PUB Series PU Braided Tube

Operating Pressure: 使用压力:0~1.8Mpa	公制型	公制管外径	公制管内径	英制型	英制管外径	英制管内径	标准长度	颜色	使用温度
	Meter Type	Tube Meter O.D.	Tube Meter I.D.	Inch Type	Tube Inch O.D.	Tube Inch I.D.	Standard Length	Colour	Operating Temperature
	PUB4X2.5	4mm	2.5mm	PUB1/8	3.175mm	-	200M	蓝,黑,橙,红,黄,白色,透明,透明蓝	-20~60℃
	PUB6X4	6mm	4mm	PUB5/32	3.969mm	-	200M		
	PUB8X5	8mm	5mm	PUB3/16	4.762mm	-	100M		
	PUB8X6	8mm	6mm	PUB1/4	6.35mm	-	100M		
	PUB10X6.5	10mm	6.5mm	PUB5/16	7.938mm	-	100M		
	PUB10X8	10mm	8mm	PUB3/8	9.525mm	-	100M		
	PUB12X8	12mm	8mm	PUB1/2	12.7mm	-	100M		
	PUB12X10	12mm	10mm	PUB5/8	15.87mm	-	100M		
	PUB14X10	14mm	10mm	PUB3/4	19.05mm	-	50M		
	PUB16X12	16mm	12mm	PUB1	25.4mm	-	50M		
	PUB16X13	16mm	13mm	PUB1-1/4	31.75mm	-	50M		

CLW系列弹簧PU软管 CLW Series Coil PU Tube

Operating Pressure: 使用压力:0~0.8Mpa	公制型	公制管外径	公制管内径	英制型	英制管外径	英制管内径	标准长度	颜色	使用温度
	Meter Type	Tube Meter O.D.	Tube Meter I.D.	Inch Type	Tube Inch O.D.	Tube Inch I.D.	Standard Length	Colour	Operating Temperature
	CLW6 × 4	6mm	4mm	CLW1/8	3.175mm	-	3M 6M 7.5M 9M 12M 15M	蓝,黑,橙,红,黄,白色,透明,透明蓝	-20~60℃
	CLW8 × 5	8mm	5mm	CLW5/32	3.969mm	-			
	CLW10 × 6.5	10mm	6.5mm	CLW3/16	4.762mm	-			
	CLW12 × 8	12mm	8mm	CLW1/4	6.35mm	-			

CXW系列双排弹簧管 CXW Series Double-Hose Coil PU Tube

Operating Pressure: 使用压力:0~0.8Mpa	公制型	公制管外径	公制管内径	英制型	英制管外径	英制管内径	标准长度	颜色	使用温度
	Meter Type	Tube Meter O.D.	Tube Meter I.D.	Inch Type	Tube Inch O.D.	Tube Inch I.D.	Standard Length	Colour	Operating Temperature
	CXW6 × 4	6mm	4mm	CLW1/8	3.175mm	-	3M 6M 7.5M 9M 12M 15M	蓝,黑,橙,红,黄,白色,透明,透明蓝	-20~60℃
	CXW8 × 5	8mm	5mm	CLW5/32	3.969mm	-			
	CXW10 × 6.5	10mm	6.5mm	CLW3/16	4.762mm	-			
	CXW12 × 8	12mm	8mm	CLW1/4	6.35mm	-			

PA6材质尼龙管 PA6 Material Nylon Tube

Operating Pressure: 使用压力:0~2.5Mpa	公制型 Meter Type	公制管外径 Tube Meter O.D.	公制管内径 Tube Meter I.D.	英制型 Inch Type	英制管外径 Tube Inch O.D.	标准长度 Standard Length	材料 Material	颜色 Colour	使用温度 Operating Temperature
	PA6-0402	4.0mm	2.0mm	PA6-1/8	3.175mm	200M	PA6	蓝,黑,橙,红,黄,白色,透明,透明蓝, Blue,Black,Orange,Red,Yellow,White Transparent,Transparent Blue	-20~120℃
	PA6-0503	5.0mm	3.0mm	PA6-5/32	3.969mm	200M			
	PA6-0604	6.0mm	4.0mm	PA6-3/16	4.762mm	200M			
	PA6-0806	8.0mm	6.0mm	PA6-1/4	6.35mm	100M			
	PA6-1075	10.0mm	7.5mm	PA6-5/16	7.938mm	100M			
	PA6-1080	10.0mm	8.0mm	PA6-3/8	9.525mm	100M			
	PA6-1290	12.0mm	9.0mm	PA6-1/2	12.7mm	100M			
	PA6-1410	14.0mm	10.0mm	PA6-5/8	15.875mm	50M			
	PA6-1612	16.0mm	12.0mm	PA6-3/4	19.05mm	50M			

PA11材质尼龙管 PA11 Material Nylon Tube

Operating Pressure: 使用压力:0~2.5Mpa	公制型 Meter Type	公制管外径 Tube Meter O.D.	公制管内径 Tube Meter I.D.	英制型 Inch Type	英制管外径 Tube Inch O.D.	标准长度 Standard Length	材料 Material	颜色 Colour	使用温度 Operating Temperature
	PA11-0402	4.0mm	2.0mm	PA11-1/8	3.175mm	200M	PA11	蓝,黑,橙,红,黄,白色,透明,透明蓝, Blue,Black,Orange,Red,Yellow,White Transparent,Transparent Blue	-20~90℃
	PA11-0503	5.0mm	3.0mm	PA11-5/32	3.969mm	200M			
	PA11-0604	6.0mm	4.0mm	PA11-3/16	4.762mm	200M			
	PA11-0806	8.0mm	6.0mm	PA11-1/4	6.35mm	100M			
	PA11-1075	10.0mm	7.5mm	PA11-5/16	7.938mm	100M			
	PA11-1080	10.0mm	8.0mm	PA11-3/8	9.525mm	100M			
	PA11-1290	12.0mm	9.0mm	PA11-1/2	12.7mm	100M			
	PA11-1410	14.0mm	10.0mm	PA11-5/8	15.875mm	50M			
	PA11-1612	16.0mm	12.0mm	PA11-3/4	19.05mm	50M			

PA12材质尼龙管 PA12 Material Nylon Tube

Operating Pressure: 使用压力:0~2.5Mpa	公制型 Meter Type	公制管外径 Tube Meter O.D.	公制管内径 Tube Meter I.D.	英制型 Inch Type	英制管外径 Tube Inch O.D.	标准长度 Standard Length	材料 Material	颜色 Colour	使用温度 Operating Temperature
	PA12-0402	4.0mm	2.0mm	PA12-1/8	3.175mm	200M	PA12	蓝,黑,橙,红,黄,白色,透明,透明蓝, Blue,Black,Orange,Red,Yellow,White Transparent,Transparent Blue	-20~90℃
	PA12-0503	5.0mm	3.0mm	PA12-5/32	3.969mm	200M			
	PA12-0604	6.0mm	4.0mm	PA12-3/16	4.762mm	200M			
	PA12-0806	8.0mm	6.0mm	PA12-1/4	6.35mm	100M			
	PA12-1075	10.0mm	7.5mm	PA12-5/16	7.938mm	100M			
	PA12-1080	10.0mm	8.0mm	PA12-3/8	9.525mm	100M			
	PA12-1290	12.0mm	9.0mm	PA12-1/2	12.7mm	100M			
	PA12-1410	14.0mm	10.0mm	PA12-5/8	15.875mm	50M			
	PA12-1612	16.0mm	12.0mm	PA12-3/4	19.05mm	50M			

PE软管 PE Tube

Operating Pressure: 使用压力:0~0.8Mpa	公制型 Meter Type	公制管外径 Tube Meter O.D.	公制管内径 Tube Meter I.D.	英制型 Inch Type	英制管外径 Tube Inch O.D.	英制管内径 Tube Inch I.D.	标准长度 Standard Length	颜色 Colour	使用温度 Operating Temperature
	PE4 × 2.5	4mm	2.5mm	PE1/8	3.175mm	-	200M	白 White	0~35℃
	PE6 × 4	6mm	4mm	PE5/32	3.969mm	-	200M		
	PE8 × 6	8mm	6mm	PE3/16	4.762mm	-	100M		
	PE10 × 7.5	10mm	7.5mm	PE1/4	6.35mm	-	100M		
	PE12 × 9	12mm	9mm	PE5/16	7.938mm	-	100M		

TLF系列铁氟龙管 TLF Series Teflon Tube

Operating Pressure: 使用压力:0~0.8Mpa	公制型 Meter Type	公制管外径 Tube Meter O.D.	公制管内径 Tube Meter I.D.	英制型 Inch Type	英制管外径 Tube Inch O.D.	长度 Length	使用温度 Operating Temperature Range	说明 Notes
	TLF0402	4.0mm	2.0mm	TLF1/8	3.175mm	200M	FEP:-85℃~205℃ PFA:-196℃~230℃ TPFE:-200℃~260℃	使用介质: 空气、水等 Using Medium: Air, Water, etc
	TLF0503	5.0mm	3.0mm	TLF5/32	3.969mm	200M		
	TLF0604	6.0mm	4.0mm	TLF3/16	4.762mm	200M		
	TLF0806	8.0mm	6.0mm	TLF1/4	6.35mm	100M		
	TLF1008	10.0mm	8.0mm	TLF5/16	7.938mm	100M		
	TLF1209	12.0mm	9.0mm	TLF3/8	9.525mm	100M		
	TLF1410	14.0mm	10.0mm	TLF1/2	12.7mm	50M		
	TLF1612	16.0mm	12.0mm	TLF5/8	15.87mm	50M		

PVC系列PVC管 PVC Series PVC Tube

Operating Pressure: 使用压力:0~0.8Mpa 	公制型 Meter Type	公制管外径 Tube Meter O.D.	公制管内径 Tube Meter I.D.	英制型 Inch Type	英制管外径 Tube Inch O.D.	标准长度 Standard Length	颜色 Colour	使用温度 Operating Temperature	说明 Notes
	PVC4X2.5	4mm	2.5mm	PVC1/8	3.175mm	200M	蓝,黑,橙,红,黄,白色,透明,透明蓝, Blue,Black,Orange,Red, Yellow,White Transparent, Transparent Blue	-20~60℃	使用介质: 空气、水等 Using Medium: Air, Water,etc
	PVC6X4	6mm	4mm	PVC5/32	3.969mm	200M			
	PVC8X5	8mm	5mm	PVC3/16	4.762mm	100M			
	PVC8X6	8mm	6mm	PVC1/4	6.35mm	100M			
	PVC10X6.5	10mm	6.5mm	PVC5/16	7.938mm	100M			
	PVC10X8	10mm	8mm	PVC3/8	9.525mm	100M			
	PVC12X8	12mm	8mm	PVC1/2	12.7mm	100M			

ST系列硅胶管 ST Series Silicone Tube

Operating Pressure: 使用压力:0~1.3Mpa 	公制型 Meter Type	公制管外径 Tube Meter O.D.	公制管内径 Tube Meter I.D.	英制型 Inch Type	英制管外径 Tube Inch O.D.	使用温度 Operating Temperature	颜色 Colour	说明 Notes
	ST0710	7mm	10mm	ST1/8	3.175mm	-40~250℃	蓝,黑,橙,红,黄,白色,透明,透明蓝, Blue,Black,Orange,Red, Yellow,White Transparent, Transparent Blue	使用介质: 空气、水等 Using Medium: Air, Water,etc ST-F:食品级 ST-F:Food Grade ST-I:工业级 ST-I:Industrial Grade
	ST0812	8mm	12mm	ST5/32	3.969mm			
	ST1014	10mm	14mm	ST3/16	4.762mm			
	ST1216	12mm	16mm	ST1/4	6.35mm			
	ST1318	13mm	18mm	ST5/16	7.938mm			
	ST1621	16mm	21mm	ST3/8	9.525mm			
	ST1925	19mm	25mm	ST1/2	12.7mm			
ST2531	25mm	31mm	ST5/8	15.87mm				

HRT系列液压树脂管 HRT Series Hydraulic Resin Tube

Operating Pressure: 使用压力:0~1.3Mpa 	型号 Model	公制管外径 Tube Meter O.D.	公制管内径 Tube Meter I.D.	工作压力 Working Pressure	爆破压力 Bursting Pressure	弯曲半径 Bending Radius	颜色 Colour	使用温度 Operating Temperature
	HRT10.2×4.8	10.2mm	4.8mm	205kgf/cm ²	610kgf/cm ²	35mm	蓝,黑,橙,红,黄,白色,透明,透明蓝, Blue,Black,Orange,Red, Yellow,White Transparent, Transparent Blue	-40~120℃
	HRT11.2×6.0	11.2mm	6.0mm	195kgf/cm ²	590kgf/cm ²	40mm		
	HRT12×6.4	12mm	6.4mm	190kgf/cm ²	570kgf/cm ²	40mm		
	HRT14.2×8	14.2mm	8.0mm	170kgf/cm ²	510kgf/cm ²	60mm		
	HRT16.6×9.6	16.6mm	9.6mm	155kgf/cm ²	470kgf/cm ²	80mm		

HST系列热缩管 HST Series Heat Shrink Tube

	型号 Model	收缩前内径 Inner Dia. Before Shrinkage	收缩前厚度 Thickness Before Shrinkage	收缩后内径 Inner Dia. After Shrinkage	收缩后厚度 Thickness After Shrinkage	包装长度 Packing Length	颜色 Colour	使用温度 Operating Temperature
	HST-4	4mm	0.5mm	≤2.8mm	0.7mm	100Meters	蓝,黑,橙,红,黄,白色,透明,透明蓝, Blue,Black,Orange,Red, Yellow,White Transparent, Transparent Blue	-55~125℃
	HST-5	5mm	0.5mm	≤3.0mm	0.7mm	100Meters		
	HST-6	6mm	0.5mm	≤3.5mm	0.7mm	100Meters		
	HST-8	8mm	0.5mm	≤4.7mm	0.7mm	100Meters		
	HST-10	10mm	1mm	≤5.8mm	1.5mm	50Meters		
	HST-12	12mm	1mm	≤7mm	1.5mm	50Meters		
	HST-15	15mm	1mm	≤9mm	1.5mm	50Meters		
	HST-20	20mm	1mm	≤13.5mm	1.5mm	50Meters		
	HST-25	25mm	1mm	≤15mm	1.5mm	50Meters		

CP系列波纹管 CP Series Corrugate Tube

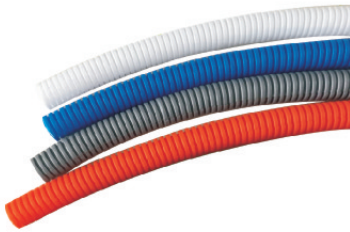
	型号 Model	公制管外径 Tube Meter O.D.	公制管内径 Tube Meter I.D.	静态弯曲半径 Static Bend Radius	动态弯曲半径 Dynamic Bending Radius	长度 Length	颜色 Colour	材料 Material
	CP10×6	10mm	6mm	15mm	35mm	200m	蓝,黑,橙,红,黄,白色,透明,透明蓝, Blue,Black,Orange,Red, Yellow,White Transparent, Transparent Blue	PA6, PA12, PE, PP, PU
	CP13×9.5	13mm	9.5mm	20mm	45mm	100m		
	CP15.8×11.5	15.8mm	11.5mm	27mm	55mm	100m		
	CP18.5×13.8	18.5mm	13.8mm	32mm	65mm	100m		
	CP21.2×16.5	21.2mm	16.5mm	40mm	75mm	100m		
	CP25×19.5	25mm	19.5mm	45mm	85mm	100m		
	CP28.5×22.5	28.5mm	22.5mm	50mm	100mm	100m		
	CP31×25.5	31mm	25.5mm	50mm	110mm	50m		
	CP34.5×28.5	34.5mm	28.5mm	55mm	120mm	50m		
	CP42.5×35.5	42.5mm	35.5mm	90mm	150mm	25m		
CP54.5×47.5	54.5mm	47.5mm	110mm	190mm	25m			

FT系列橡胶软管 FT Series Rubber Flexible Tube

<p>Operating Pressure: 使用压力:0~1.3Mpa</p> 	型号 Model	螺纹 Thread Size	长度 Length	使用温度 Operating Temperature	说明 Notes
	FT034070	G3/4	0.7M		
	FT001070	G1	0.7M		
	FT114070	G1-1/4	0.7M		
	FT002070	G2	0.7M		
	FT034150	G3/4	1.5M		
	FT001150	G1	1.5M		
	FT114150	G1-1/4	1.5M		
	FT002150	G2	1.5M		
				-20~70℃	使用介质: 空气、水等 Using Medium: Air, Water, etc

OEL/OELS系列冷却管 OEL/OELS Series Cooling Tube

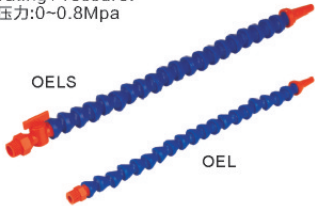
<p>Operating Pressure: 使用压力:0~0.8Mpa</p> 	型号 Model	螺纹尺寸 Port Size	喷嘴样式 Nozzle Type	说明 Notes			
	OEL-01	PT1/8					
	OEL-02	PT1/4					
	OEL-03	PT3/8					
	OEL-04	PT1/2					
	OEL-06	PT3/4					
	OEL-08	PT1"					
					O:圆头喷嘴 F:扁头喷嘴 O:Round Nozzle F:Flat Nozzle		
					OEL:标准型 OELS:带开关 OEL:Standard OELS:With Switch		

BPV系列冷却管(附精密阀) BPV Series Cooling Tube (With Precision Valve)

<p>Operating Pressure: 使用压力:0~0.8Mpa</p> 	型号 Model	螺纹尺寸 Port Size	喷嘴样式 Nozzle Type	
	BPV-1000	PT1/8		
	BPV-2000	PT1/4		
	BPV-3000	PT3/8		
	BPV-4000	PT1/2		
	BPV-6000	PT3/4		
	BPV-8000	PT1"		
				O:圆头喷嘴 F:扁头喷嘴 O:Round Nozzle F:Flat Nozzle

SWT系列不锈钢穿线软管 SWT Series Stainless Steel Wire Tube

	型号 Model	管内径 Tube I. D.	长度 Length	使用温度 Operating Temperature	说明 Notes
	SWT-4	4mm	1M,3M,6M,9M		
	SWT-5	5mm	1M,3M,6M,9M		
	SWT-6	6mm	1M,3M,6M,9M		
	SWT-7	7mm	1M,3M,6M,9M		
	SWT-8	8mm	1M,3M,6M,9M		
	SWT-10	10mm	1M,3M,6M,9M		
	SWT-12	12mm	1M,3M,6M,9M		
	SWT-15	15mm	1M,3M,6M,9M		
	SWT-20	20mm	1M,3M,6M,9M		
	SWT-25	25mm	1M,3M,6M,9M		
	SWT-32	32mm	1M,3M,6M,9M		
	SWT-38	38mm	1M,3M,6M,9M		
	SWT-64	64mm	1M,3M,6M,9M		

AP系列铝管 AP Series Aluminium Tube

<p>Operating Pressure: 使用压力:0~1.3Mpa</p> 	型号 Model	管外径 Tube O. D.	管内径 Tube I. D.	长度 Length	使用温度 Operating Temperature	说明 Notes
	AP2017	20mm	17mm	3M,6M,9M		
	AP2522	25mm	22mm	3M,6M,9M		
	AP3229	32mm	29mm	3M,6M,9M		
	AP4037	40mm	37mm	3M,6M,9M		
	AP5046	50mm	46mm	3M,6M,9M		
	AP6359	63mm	59mm	3M,6M,9M		
	AP7672	76mm	72mm	3M,6M,9M		
	AP8075	80mm	75mm	3M,6M,9M		
	AP10094	100mm	95mm	3M,6M,9M		

华拓牌HT系列自锁式尼龙扎带 HUATOP HT Series Self-Locking Nylon Cable Ties

型号 Model	宽 Width	长度 Length		捆扎范围 Bundle Diameter	承受力 Tensile Strength		颜色 Colour
		INCH	MM		IBS	KGS	
HT-2.5 × 60	2.5 mm	2.4"	60 mm	2~11 mm	18	8	蓝,黑,橙,红 黄,白色, 透明, 透明蓝,
HT-2.5 × 80	2.5 mm	3.2"	80 mm	2~16 mm	18	8	
HT-2.5 × 100	2.5 mm	4.0"	100 mm	2~22 mm	18	8	
HT-2.5 × 120	2.5 mm	4.7"	120 mm	2~30 mm	18	8	
HT-2.5 × 150	2.5 mm	6.0"	150 mm	2~35 mm	18	8	
HT-2.5 × 160	2.5 mm	6.3"	160 mm	2~40 mm	18	8	
HT-2.5 × 200	2.5 mm	8.0"	200 mm	3~50 mm	18	8	
HT-3.6 × 140	3.6 mm	5.5"	140 mm	3~33 mm	40	18	
HT-3.6 × 150	3.6 mm	6.0"	150 mm	3~35 mm	40	18	
HT-3.6 × 180	3.6 mm	7.1"	180 mm	3~42 mm	40	18	
HT-3.6 × 200	3.6 mm	8.0"	200 mm	3~50 mm	40	18	
HT-3.6 × 250	3.6 mm	10"	250 mm	3~65 mm	40	18	
HT-3.6 × 280	3.6 mm	11"	280 mm	3~70 mm	40	18	
HT-3.6 × 300	3.6 mm	12"	300 mm	3~80 mm	40	18	
HT-3.6 × 370	3.6 mm	14.6"	370 mm	3~105 mm	40	18	
HT-4 × 100	3.6 mm	4"	100 mm	2~11 mm	40	18	
HT-4 × 350	3.6 mm	13.7"	350 mm	3~90 mm	40	18	
HT-4.8 × 120	4.8 mm	4.7"	120 mm	3~30 mm	50	22	
HT-4.8 × 160	4.8 mm	6.3"	160 mm	3~40 mm	50	22	
HT-4.8 × 180	4.8 mm	7.1"	180 mm	3~42 mm	50	22	
HT-4.8 × 190	4.8 mm	7.5"	190 mm	3~46 mm	50	22	
HT-4.8 × 200	4.8 mm	8.0"	200 mm	3~50 mm	50	22	
HT-4.8 × 250	4.8 mm	10"	250 mm	3~65 mm	50	22	
HT-4.8 × 280	4.8 mm	11"	280 mm	3~70 mm	50	22	
HT-4.8 × 300	4.8 mm	12"	300 mm	3~80 mm	50	22	
HT-4.8 × 350	4.8 mm	14"	350 mm	3~90 mm	50	22	
HT-4.8 × 360	4.8 mm	14.2"	360 mm	3~94 mm	50	22	
HT-4.8 × 370	4.8 mm	14.6"	370 mm	3~98 mm	50	22	
HT-4.8 × 380	4.8 mm	15"	380 mm	3~102 mm	50	22	
HT-4.8 × 400	4.8 mm	16"	400 mm	3~105 mm	50	22	
HT-4.8 × 430	4.8 mm	16.9"	430 mm	3~120 mm	50	22	
HT-4.8 × 450	4.8 mm	17.7"	450 mm	3~130 mm	50	22	
HT-4.8 × 500	4.8 mm	19.7"	500 mm	3~150 mm	50	22	
HT-5 × 150	4.8 mm	6"	150 mm	3~35 mm	50	22	
HT-5 × 610	4.8 mm	24"	610 mm	8~170 mm	50	22	
HT-7.2 × 150	7.2mm	6.0"	150 mm	3~35 mm	120	55	
HT-7.2 × 200	7.2mm	8.0"	200 mm	3~50 mm	120	55	
HT-7.2 × 250	7.2mm	10"	250 mm	4~65 mm	120	55	
HT-7.2 × 280	7.2mm	11"	280 mm	4~78 mm	120	55	
HT-7.2 × 300	7.2mm	12"	300 mm	4~80 mm	120	55	
HT-7.2 × 350	7.2mm	14"	350 mm	4~90 mm	120	55	
HT-7.2 × 370	7.2mm	14.6"	370 mm	4~98 mm	120	55	
HT-7.2 × 380	7.2mm	15"	380 mm	4~100 mm	120	55	
HT-7.2 × 400	7.2mm	16"	400 mm	4~105 mm	120	55	
HT-7.2 × 450	7.2mm	18"	450 mm	4~110 mm	120	55	
HT-7.2 × 500	7.2mm	20"	500 mm	4~150 mm	120	55	
HT-7.2 × 530	7.2mm	20.9"	530 mm	4~160 mm	120	55	
HT-7.2 × 550	7.2mm	21.6"	550 mm	4~165 mm	120	55	
HT-7.2 × 750	7.2mm	29.5"	750 mm	4~225 mm	120	55	

蓝,黑,橙,红
黄,白色,
透明,
透明蓝,

Blue,
Black,
Orange,
Red,
Yellow,
White
Transparent,
Transparent Blue

MO系列液压缸 MO Series Hydraulic Cylinder

Operating Pressure: 使用压力:0~14Mpa	型号	缸径	接管尺寸	活塞杆螺纹尺寸	最大理论出力	派生型号	说明	
	Model	Bore	Port size	Piston port size	Max Theoretical Output	Derivative Model	Notes	
		MO32	32	PT1/4	M14 × 1.5	562N.m	MO: 标准复动拉杆式 MOD: 双轴型标准气缸 MOJ: 双轴可调型标准气缸	螺纹类型: -PT: PT螺纹 -NPT: NPT 螺纹 -G: G螺纹
		MO40	40	PT3/8	M16 × 1.5	880N.m		
		MO50	50	PT3/8	M16 × 1.5	1373N.m		
		MO63	63	PT3/8	M22 × 1.5	2180N.m		
		MO80	80	PT1/2	M26 × 1.5	3516N.m	MO: Double Acting Pull Rod Type MOD: Double Rods Standard Type MOJ: Double Rods Adjustabel Type	Thread Type: -PT: PT Thread -NPT: NPT Thread -G: G Thread
		MO100	100	PT1/2	M30 × 1.5	5495N.m		
	MO125	125	PT1/2	M40 × 2	8586N.m			
	MO160	160	PT3/4	M52 × 2	14067N.m			

HO系列液压缸 HO Series Hydraulic Cylinder

Operating Pressure: 使用压力:0~14Mpa	型号	缸径	接管尺寸	活塞杆螺纹尺寸	最大理论出力	派生型号	说明	
	Model	Bore	Port size	Piston port size	Max Theoretical Output	Derivative Model	Notes	
		HO40	40	PT3/8	M22 × 1.5	1758N.m	HO: 标准复动拉杆式 HOD: 双轴型标准气缸 HOJ: 双轴可调型标准气缸	螺纹类型: -PT: PT螺纹 -NPT: NPT 螺纹 -G: G螺纹
		HO50	50	PT3/8	M26 × 1.5	2746N.m		
		HO63	63	PT3/8	M30 × 1.5	4362N.m		
		HO80	80	PT1/2	M30 × 1.5	7034N.m		
		HO100	100	PT1/2	M40 × 2	10995N.m	HO: Double Acting Pull Rod Type HOD: Double Rods Standard Type HOJ: Double Rods Adjustabel Type	Thread Type: -PT: PT Thread -NPT: NPT Thread -G: G Thread
		HO125	125	PT3/4	M50 × 2	17172N.m		
	HO160	160	PT3/4	M70 × 2	28134N.m			
	HO200	200	PT1"	M90 × 2	43960N.m			

G02系列液压电磁阀 G02 Series Hydraulic Solenoid Valve

	型号	最大允许工作压力	粘度范围	工作介质温度	使用介质	电压	说明
	Model	Max. Working Press	Viscosity Range	Medium Temperature	Using Medium	Voltage	Notes
	G02-2B-20/220V	25MPa	2.8~380CST	-30~70℃	液压油 Hydraulic Oil	DC24V AC110V AC220V	螺纹类型: -PT: PT螺纹 -NPT: NPT 螺纹 -G: G螺纹 Thread Type: -PT: PT Thread -NPT: NPT Thread -G: G Thread
	G02-2B-20/24V	25MPa	2.8~380CST	-30~70℃			
	G02-2B-10/220V	25MPa	2.8~380CST	-30~70℃			
	G02-2B-10/24V	25MPa	2.8~380CST	-30~70℃			
	G02-3C-20/220V	25MPa	2.8~380CST	-30~70℃			
	G02-3C-20/24V	25MPa	2.8~380CST	-30~70℃			
	G02-3C-10/220V	25MPa	2.8~380CST	-30~70℃			
	G02-3C-10/24V	25MPa	2.8~380CST	-30~70℃			
	G02-3C6-20/220V	25MPa	2.8~380CST	-30~70℃			
	G02-3C6-20/24V	25MPa	2.8~380CST	-30~70℃			
	G02-3C6-10/220V	25MPa	2.8~380CST	-30~70℃			
G02-3C6-10/24V	25MPa	2.8~380CST	-30~70℃				

G03系列液压电磁阀 G03 Series Hydraulic Solenoid Valve

	型号	最大允许工作压力	粘度范围	工作介质温度	使用介质	电压	说明
	Model	Max. Working Press	Viscosity Range	Medium Temperature	Using Medium	Voltage	Notes
	G03-2B-20/220V	25MPa	2.8~380CST	-30~70℃	液压油 Hydraulic Oil	DC24V AC110V AC220V	螺纹类型: -PT: PT螺纹 -NPT: NPT 螺纹 -G: G螺纹 Thread Type: -PT: PT Thread -NPT: NPT Thread -G: G Thread
	G03-2B-20/24V	25MPa	2.8~380CST	-30~70℃			
	G03-2B-10/220V	25MPa	2.8~380CST	-30~70℃			
	G03-2B-10/24V	25MPa	2.8~380CST	-30~70℃			
	G03-3C-20/220V	25MPa	2.8~380CST	-30~70℃			
	G03-3C-20/24V	25MPa	2.8~380CST	-30~70℃			
	G03-3C-10/220V	25MPa	2.8~380CST	-30~70℃			
	G03-3C-10/24V	25MPa	2.8~380CST	-30~70℃			
	G03-3C6-20/220V	25MPa	2.8~380CST	-30~70℃			
	G03-3C6-20/24V	25MPa	2.8~380CST	-30~70℃			
	G03-3C6-10/220V	25MPa	2.8~380CST	-30~70℃			
G03-3C6-10/24V	25MPa	2.8~380CST	-30~70℃				

FC系列油压缓冲器 FC Series Shock Absorbers

型号 Model	最大吸收能量 Max. Absorbing Energy	最大允许推力 Max. Allowable Push Force	允许速度 Shock Speed (m/sec)	行程 Stroke	螺纹尺寸 Port Size	工件及环境温度 Ambient & Fluid Temperature
FC1410	20	120	3.2	10mm	M14 × 1.5	-10~80℃
FC1412	20	120	3.2	12mm	M14 × 1.5	-10~80℃
FC1416	22	150	3.2	16mm	M14 × 1.5	-10~80℃
FC1420	22	150	3.2	20mm	M14 × 1.5	-10~80℃
FC1425	25	150	3.2	25mm	M14 × 1.5	-10~80℃
FC2016	28	224	3.2	16mm	M20 × 1.5	-10~80℃
FC2020	35	280	3.2	20mm	M20 × 1.5	-10~80℃
FC2025	40	330	3.2	25mm	M20 × 1.5	-10~80℃
FC2030	45	450	3.2	30mm	M20 × 1.5	-10~80℃
FC2050	60	500	3.2	50mm	M20 × 1.5	-10~80℃
FC2525	78	624	3.5	25mm	M25 × 1.5	-10~80℃
FC2530	105	785	3.5	30mm	M25 × 1.5	-10~80℃
FC2540	122	976	3.5	40mm	M25 × 1.5	-10~80℃
FC2550	148	1048	3.5	50mm	M25 × 1.5	-10~80℃
FC2580	190	1100	3.2	80mm	M25 × 1.5	-10~80℃
FC3625	180	880	3.2	25mm	M36 × 1.5	-10~80℃
FC3650	220	1760	3.2	50mm	M36 × 1.5	-10~80℃
FC4225	280	3200	3.7	25mm	M42 × 1.5	-10~80℃

AC系列油压缓冲器 AC Series Shock Absorbers

型号 Model	最大吸收能量 Max. Absorbing Energy	最大允许推力 Max. Allowable Push Force	允许速度 Shock Speed (m/sec)	行程 Stroke	螺纹尺寸 Port Size	工件及环境温度 Ambient & Fluid Temperature
AC0806	2	6	0.8~2	6mm	M8 × 1	-10~80℃
AC1005	3	7	0.8~3	5mm	M10 × 1	-10~80℃
AC1008	4	9	0.8~3	8mm	M10 × 1	-10~80℃
AC1210	5	30	0.8~3	10mm	M12 × 1	-10~80℃
AC1410	13	100	0.8~3	10mm	M14 × 1.5	-10~80℃
AC1412	15	110	0.8~3	12mm	M14 × 1.5	-10~80℃
AC1416	20	150	0.8~3	16mm	M14 × 1.5	-10~80℃
AC1420	22	160	0.8~3	20mm	M14 × 1.5	-10~80℃
AC1425	25	170	0.8~3	25mm	M14 × 1.5	-10~80℃
AC2015	35	600	1.0~3.2	15mm	M20 × 1.5	-10~80℃
AC2020	40	700	1.0~3.5	20mm	M20 × 1.5	-10~80℃
AC2025	45	720	1.0~3.5	25mm	M20 × 1.5	-10~80℃
AC2030	50	750	1.0~3.5	30mm	M20 × 1.5	-10~80℃
AC2050	60	1200	1.0~3.5	50mm	M20 × 1.5	-10~80℃
AC2525	80	1500	1.0~4.0	25mm	M25 × 1.5	-10~80℃
AC2530	90	1800	1.0~4.0	30mm	M25 × 1.5	-10~80℃
AC2540	120	2000	1.0~4.0	40mm	M25 × 1.5	-10~80℃
AC2550	100	160	1.0~4.0	50mm	M25 × 1.5	-10~80℃
AC2580	150	200	1.0~4.0	80mm	M25 × 1.5	-10~80℃
AC3660	250	2400	1.0~4.0	60mm	M36 × 1.5	-10~80℃

HR系列油压缓冲器 HR Series Shock Absorbers

型号 Model	最大吸收能量 Max. Absorbing Energy	最大允许推力 Max. Allowable Push Force	允许速度 Shock Speed (m/sec)	行程 Stroke	工件及环境温度 Ambient & Fluid Temperature
HR-15	0.23kgf/m	3500 N	0.5~30	15mm	-10~80℃
HR-30	0.23kgf/m	3500 N	0.5~30	30mm	-10~80℃
HR-60	0.23kgf/m	3500 N	0.5~30	60mm	-10~80℃
HR-80	0.23kgf/m	3500 N	0.5~30	80mm	-10~80℃
HR-100	0.23kgf/m	3500 N	0.5~30	100mm	-10~80℃

HRT系列油压缓冲器 HRT Series Shock Absorbers

型号 Model	最大负荷 Max. Absorbing Energy	行程 Stroke	工件及环境温度 Ambient & Fluid Temperature	说明 Notes
HRT-60	350Kgf	60mm	-10~80℃	螺纹类型: -PT: PT 螺纹 -NPT: NPT 螺纹 -G: G 螺纹 Thread Type: -PT: PT Thread -NPT: NPT Thread -G: G Thread
HRT-100	350Kgf	100mm	-10~80℃	

D系列阻拦缸用可调式缓冲器 D Series Adjustable Shock Absorbers Of Stopper Cylinder

型号 Model	行程 Stroke	每次最大吸收能量 Max Absorbing Energy Per Cycle E	小时最大吸收能量 Max. Absorbing Energy/Hour Ec	最大有效重量 Max Effective Mass Me	最高冲击速度 Max Impact Speed	工件及环境温度 Ambient&Fluid Temperature	说明 Notes
ZD-1408	8mm	16Nm	12000Nm/hr	40Kg	4.0m/s	-10~85℃	螺纹类型: -PT: PT螺纹 -NPT: NPT 螺纹 -G: G螺纹
ZD-2210	10mm	35Nm	2000Nm/hr	25Kg	3.5m/s	-10~85℃	Thread Type: -PT: PT Thread -NPT: NPT Thread -G: G Thread

CIT系列液压单向阀 CIT Series Check Valve

型号 Model	接管尺寸 Port Size	额定流量 Rated Flow	最高使用压力 Max. Operating Pressure	使用流体 Fluid	材质 Material	说明 Notes
CIT-02	G1/4	40	25Mpa	油品 Oil	铸铁 Wrought Iron	螺纹类型: -PT: PT螺纹 -NPT: NPT 螺纹 -G: G螺纹 Thread Type: -PT: PT Thread -NPT: NPT Thread -G: G Thread
CIT-03	G3/8	60	25Mpa			
CIT-04	G1/2	100	25Mpa			
CIT-06	G3/4	180	25Mpa			
CIT-08	G1	350	25Mpa			





KC液压流量控制阀 KC Series Hydraulic Control Valve

型号 Model	接管尺寸 Port Size	额定流量 Rated Flow	最高使用压力 Max. Operating Pressure	使用流体 Fluid	材质 Material	说明 Notes
KC-02	G1/4	12	25Mpa	油品 Oil	铸铁 Wrought Iron	螺纹类型: -PT: PT螺纹 -NPT: NPT 螺纹 -G: G螺纹 Thread Type: -PT: PT Thread -NPT: NPT Thread -G: G Thread
KC-03	G3/8	20	25Mpa			
KC-04	G1/2	30	25Mpa			
KC-06	G3/4	48	25Mpa			

液压快速接头 Hydraulic Quick Couplings

型号 Model	接口尺寸 Port Size	接口尺寸 Port Size	接口尺寸 Port Size	接口尺寸 Port Size	接口尺寸 Port Size	接口尺寸 Port Size	接口尺寸 Port Size	接口尺寸 Port Size	接口尺寸 Port Size	接口尺寸 Port Size	接口尺寸 Port Size	接口尺寸 Port Size	接口尺寸 Port Size	接口尺寸 Port Size	接口尺寸 Port Size	接口尺寸 Port Size	接口尺寸 Port Size	接口尺寸 Port Size	接口尺寸 Port Size																		
KZE-PF	1/8	KZE-SF	1/8	KZEB-PF	1/8	KZEB-SF	1/8	KZESS-PF	1/8	KZESS-SF	1/8	KZB-PF	1/8	KZB-SF	1/8	KZD-PF	1/8	KZD-SF	1/8	KZBSS-PF	1/8	KZBSS-SF	1/8														
	1/4		1/4		1/4		1/4		1/4		1/4		1/4		1/4		1/4		1/4		1/4		1/4	1/4	1/4	1/4	1/4	1/4	1/4	1/4	1/4	1/4					
	3/8		3/8		3/8		3/8		3/8		3/8		3/8		3/8		3/8		3/8		3/8		3/8	3/8	3/8	3/8	3/8	3/8	3/8	3/8	3/8	3/8	3/8	3/8			
	1/2		1/2		1/2		1/2		1/2		1/2		1/2		1/2		1/2		1/2		1/2		1/2	1/2	1/2	1/2	1/2	1/2	1/2	1/2	1/2	1/2	1/2	1/2	1/2		
	3/4		3/4		3/4		3/4		3/4		3/4		3/4		3/4		3/4		3/4		3/4		3/4	3/4	3/4	3/4	3/4	3/4	3/4	3/4	3/4	3/4	3/4	3/4	3/4	3/4	
	1		1		1		1		1		1		1		1		1		1		1		1	1	1	1	1	1	1	1	1	1	1	1	1	1	
1-1/4	1-1/4	1-1/4	1-1/4	1-1/4	1-1/4	1-1/4	1-1/4	1-1/4	1-1/4	1-1/4	1-1/4	1-1/4	1-1/4	1-1/4	1-1/4	1-1/4	1-1/4	1-1/4	1-1/4	1-1/4	1-1/4	1-1/4	1-1/4	1-1/4	1-1/4												
QKPT-PF	1/8	QKPT-SF	1/8	QKTS-PF	1/8	QKTS-SF	1/8	QKTL-PF	1/8	QKTL-SF	1/8	QTL-PF	1/8	QTL-SF	1/8	QTL-PF	1/8	QTL-SF	1/8	QTL-PF	1/8	QTL-SF	1/8	QTL-PF	1/8												
	1/4		1/4		1/4		1/4		1/4		1/4		1/4		1/4		1/4		1/4		1/4		1/4		1/4	1/4	1/4	1/4	1/4	1/4	1/4	1/4	1/4	1/4			
	3/8		3/8		3/8		3/8		3/8		3/8		3/8		3/8		3/8		3/8		3/8		3/8		3/8	3/8	3/8	3/8	3/8	3/8	3/8	3/8	3/8	3/8	3/8	3/8	
	1/2		1/2		1/2		1/2		1/2		1/2		1/2		1/2		1/2		1/2		1/2		1/2		1/2	1/2	1/2	1/2	1/2	1/2	1/2	1/2	1/2	1/2	1/2	1/2	1/2
	3/4		3/4		3/4		3/4		3/4		3/4		3/4		3/4		3/4		3/4		3/4		3/4		3/4	3/4	3/4	3/4	3/4	3/4	3/4	3/4	3/4	3/4	3/4	3/4	3/4
	1		1		1		1		1		1		1		1		1		1		1		1		1	1	1	1	1	1	1	1	1	1	1	1	1
1-1/4	1-1/4	1-1/4	1-1/4	1-1/4	1-1/4	1-1/4	1-1/4	1-1/4	1-1/4	1-1/4	1-1/4	1-1/4	1-1/4	1-1/4	1-1/4	1-1/4	1-1/4	1-1/4	1-1/4	1-1/4	1-1/4	1-1/4	1-1/4	1-1/4	1-1/4												

液压接头 Hydraulic Fitting

<p>BA</p> 	<p>螺纹 × 螺纹 Outer Thread × Inner Thread</p> <table border="1"> <tr><td>1/8-1/4</td></tr> <tr><td>1/8-3/8</td></tr> <tr><td>1/4-3/8</td></tr> <tr><td>1/4-1/2</td></tr> <tr><td>3/8-1/2</td></tr> <tr><td>1/2-3/4</td></tr> <tr><td>1/4-M14X1.5</td></tr> <tr><td>1/2-M14X1.5</td></tr> <tr><td>1/4-M20X1.5</td></tr> </table>	1/8-1/4	1/8-3/8	1/4-3/8	1/4-1/2	3/8-1/2	1/2-3/4	1/4-M14X1.5	1/2-M14X1.5	1/4-M20X1.5	<p>BB</p> 	<p>螺纹 × 螺纹 Outer Thread × Inner Thread</p> <table border="1"> <tr><td>1/4-1/8</td></tr> <tr><td>3/8-1/8</td></tr> <tr><td>3/8-1/4</td></tr> <tr><td>1/2-1/4</td></tr> <tr><td>1/2-3/8</td></tr> <tr><td>3/4-1/2</td></tr> <tr><td>1"-1/2</td></tr> <tr><td>1"-3/4</td></tr> </table>	1/4-1/8	3/8-1/8	3/8-1/4	1/2-1/4	1/2-3/8	3/4-1/2	1"-1/2	1"-3/4	<p>BC</p> 	<p>管外径 × 螺纹 Tube OD. × Thread Size</p> <table border="1"> <tr><td>1/8</td></tr> <tr><td>1/4</td></tr> <tr><td>3/8</td></tr> <tr><td>1/2</td></tr> <tr><td>3/4</td></tr> <tr><td>1</td></tr> </table>	1/8	1/4	3/8	1/2	3/4	1																
1/8-1/4																																												
1/8-3/8																																												
1/4-3/8																																												
1/4-1/2																																												
3/8-1/2																																												
1/2-3/4																																												
1/4-M14X1.5																																												
1/2-M14X1.5																																												
1/4-M20X1.5																																												
1/4-1/8																																												
3/8-1/8																																												
3/8-1/4																																												
1/2-1/4																																												
1/2-3/8																																												
3/4-1/2																																												
1"-1/2																																												
1"-3/4																																												
1/8																																												
1/4																																												
3/8																																												
1/2																																												
3/4																																												
1																																												
<p>BD</p> 	<p>螺纹 × 螺纹 Thread Size × Thread Size</p> <table border="1"> <tr><td>1/8</td></tr> <tr><td>1/4</td></tr> <tr><td>3/8</td></tr> <tr><td>1/2</td></tr> <tr><td>3/4</td></tr> <tr><td>1</td></tr> </table>	1/8	1/4	3/8	1/2	3/4	1	<p>BE</p> 	<p>螺纹 × 螺纹 Thread Size × Thread Size</p> <table border="1"> <tr><td>3/8-1/4-1/4-1/4</td></tr> <tr><td>3/8-3/8-3/8-3/8</td></tr> <tr><td>1/4-1/4-1/4-1/4</td></tr> </table>	3/8-1/4-1/4-1/4	3/8-3/8-3/8-3/8	1/4-1/4-1/4-1/4	<p>BF</p> 	<p>管内径 × 螺纹 Tube ID. × Thread Size</p> <table border="1"> <tr><td>6-01</td><td>10-04</td></tr> <tr><td>6-02</td><td>12-02</td></tr> <tr><td>8-01</td><td>12-03</td></tr> <tr><td>8-02</td><td>12-04</td></tr> <tr><td>8-03</td><td>16-04</td></tr> <tr><td>8-04</td><td>19-06</td></tr> <tr><td>10-01</td><td>10-06</td></tr> <tr><td>10-02</td><td>12-06</td></tr> <tr><td>10-03</td><td>16-06</td></tr> </table>	6-01	10-04	6-02	12-02	8-01	12-03	8-02	12-04	8-03	16-04	8-04	19-06	10-01	10-06	10-02	12-06	10-03	16-06												
1/8																																												
1/4																																												
3/8																																												
1/2																																												
3/4																																												
1																																												
3/8-1/4-1/4-1/4																																												
3/8-3/8-3/8-3/8																																												
1/4-1/4-1/4-1/4																																												
6-01	10-04																																											
6-02	12-02																																											
8-01	12-03																																											
8-02	12-04																																											
8-03	16-04																																											
8-04	19-06																																											
10-01	10-06																																											
10-02	12-06																																											
10-03	16-06																																											
<p>BG</p> 	<p>管内径 × 螺纹 Tube ID. × Thread Size</p> <table border="1"> <tr><td>6-01</td><td>10-01</td><td>12-06</td></tr> <tr><td>6-02</td><td>10-02</td><td>14-02</td></tr> <tr><td>6-03</td><td>10-03</td><td>14-03</td></tr> <tr><td>6-04</td><td>10-04</td><td>14-04</td></tr> <tr><td>8-01</td><td>10-06</td><td>14-06</td></tr> <tr><td>8-02</td><td>12-01</td><td>16-03</td></tr> <tr><td>8-03</td><td>12-02</td><td>16-04</td></tr> <tr><td>8-04</td><td>12-03</td><td>16-06</td></tr> <tr><td>8-06</td><td>12-04</td><td></td></tr> </table>	6-01	10-01	12-06	6-02	10-02	14-02	6-03	10-03	14-03	6-04	10-04	14-04	8-01	10-06	14-06	8-02	12-01	16-03	8-03	12-02	16-04	8-04	12-03	16-06	8-06	12-04		<p>BH</p> 	<p>螺纹 × 螺纹 Thread Size × Thread Size</p> <table border="1"> <tr><td>1/8</td></tr> <tr><td>1/4</td></tr> <tr><td>3/8</td></tr> <tr><td>1/2</td></tr> <tr><td>3/4</td></tr> <tr><td>1</td></tr> </table>	1/8	1/4	3/8	1/2	3/4	1	<p>BI</p> 	<p>螺纹 × 螺纹 Thread Size × Thread Size</p> <table border="1"> <tr><td>1/8-1/8-1/8</td></tr> <tr><td>1/4-1/4-1/4</td></tr> <tr><td>3/8-3/8-3/8</td></tr> <tr><td>1/2-1/2-1/2</td></tr> <tr><td>3/4-3/4-3/4</td></tr> <tr><td>1-1-1</td></tr> </table>	1/8-1/8-1/8	1/4-1/4-1/4	3/8-3/8-3/8	1/2-1/2-1/2	3/4-3/4-3/4	1-1-1
6-01	10-01	12-06																																										
6-02	10-02	14-02																																										
6-03	10-03	14-03																																										
6-04	10-04	14-04																																										
8-01	10-06	14-06																																										
8-02	12-01	16-03																																										
8-03	12-02	16-04																																										
8-04	12-03	16-06																																										
8-06	12-04																																											
1/8																																												
1/4																																												
3/8																																												
1/2																																												
3/4																																												
1																																												
1/8-1/8-1/8																																												
1/4-1/4-1/4																																												
3/8-3/8-3/8																																												
1/2-1/2-1/2																																												
3/4-3/4-3/4																																												
1-1-1																																												
<p>BJ</p> 	<p>管外径 × 螺纹 Tube OD. × Thread Size</p> <table border="1"> <tr><td>1/8-4</td></tr> <tr><td>1/8-φ6</td></tr> <tr><td>8-1-4</td></tr> <tr><td>8-1-6</td></tr> <tr><td>10-1-4</td></tr> <tr><td>10-1-6</td></tr> <tr><td>6-6</td></tr> </table>	1/8-4	1/8-φ6	8-1-4	8-1-6	10-1-4	10-1-6	6-6	<p>BK</p> 	<p>螺纹 × 螺纹 Thread Size × Thread Size</p> <table border="1"> <tr><td>1/2-1/4-1/4</td></tr> <tr><td>1/4-1/8-1/8</td></tr> <tr><td>1"-3/4-3/4</td></tr> </table>	1/2-1/4-1/4	1/4-1/8-1/8	1"-3/4-3/4	<p>BL</p> 	<p>螺纹 × 螺纹 Thread Size × Thread Size</p> <table border="1"> <tr><td>1/8-1/8</td></tr> <tr><td>1/4-1/4</td></tr> <tr><td>3/8-3/8</td></tr> <tr><td>1/2-1/2</td></tr> <tr><td>3/4-3/4</td></tr> <tr><td>1"-1"</td></tr> </table>	1/8-1/8	1/4-1/4	3/8-3/8	1/2-1/2	3/4-3/4	1"-1"																							
1/8-4																																												
1/8-φ6																																												
8-1-4																																												
8-1-6																																												
10-1-4																																												
10-1-6																																												
6-6																																												
1/2-1/4-1/4																																												
1/4-1/8-1/8																																												
1"-3/4-3/4																																												
1/8-1/8																																												
1/4-1/4																																												
3/8-3/8																																												
1/2-1/2																																												
3/4-3/4																																												
1"-1"																																												
<p>BM</p> 	<p>螺纹 × 螺纹 Thread Size × Thread Size</p> <table border="1"> <tr><td>1/8-1/8-1/8</td></tr> <tr><td>1/4-1/4-1/4</td></tr> <tr><td>3/8-3/8-3/8</td></tr> <tr><td>1/2-1/2-1/2</td></tr> <tr><td>3/4-3/4-3/4</td></tr> <tr><td>1/1-1-1</td></tr> </table>	1/8-1/8-1/8	1/4-1/4-1/4	3/8-3/8-3/8	1/2-1/2-1/2	3/4-3/4-3/4	1/1-1-1	<p>BN</p> 	<p>螺纹 × 螺纹 Thread Size × Thread Size</p> <table border="1"> <tr><td>1/8-1/8</td></tr> <tr><td>1/4-1/4</td></tr> <tr><td>3/8-3/8</td></tr> <tr><td>1/2-1/2</td></tr> <tr><td>3/4-3/4-3/4</td></tr> <tr><td>1/1-1-1</td></tr> </table>	1/8-1/8	1/4-1/4	3/8-3/8	1/2-1/2	3/4-3/4-3/4	1/1-1-1	<p>BO</p> 	<p>接管尺寸 Port Size</p> <table border="1"> <tr><td>1/8</td></tr> <tr><td>1/4</td></tr> <tr><td>3/8</td></tr> <tr><td>1/2</td></tr> <tr><td>3/4</td></tr> <tr><td>1</td></tr> </table>	1/8	1/4	3/8	1/2	3/4	1																					
1/8-1/8-1/8																																												
1/4-1/4-1/4																																												
3/8-3/8-3/8																																												
1/2-1/2-1/2																																												
3/4-3/4-3/4																																												
1/1-1-1																																												
1/8-1/8																																												
1/4-1/4																																												
3/8-3/8																																												
1/2-1/2																																												
3/4-3/4-3/4																																												
1/1-1-1																																												
1/8																																												
1/4																																												
3/8																																												
1/2																																												
3/4																																												
1																																												
<p>BP</p> 	<p>螺纹 × 螺纹 Thread Size × Thread Size</p> <table border="1"> <tr><td>1/8</td></tr> <tr><td>1/4</td></tr> <tr><td>3/8</td></tr> <tr><td>1/2</td></tr> <tr><td>3/4</td></tr> <tr><td>1</td></tr> </table>	1/8	1/4	3/8	1/2	3/4	1	<p>BQ</p> 	<p>螺纹 × 螺纹 Thread Size × Thread Size</p> <table border="1"> <tr><td>1/8</td></tr> <tr><td>1/4</td></tr> <tr><td>3/8</td></tr> <tr><td>1/2</td></tr> <tr><td>3/4</td></tr> <tr><td>1</td></tr> </table>	1/8	1/4	3/8	1/2	3/4	1	<p>BR</p> 	<p>接管尺寸 Port Size</p> <table border="1"> <tr><td>1/8</td></tr> <tr><td>1/4</td></tr> <tr><td>3/8</td></tr> <tr><td>1/2</td></tr> <tr><td>3/4</td></tr> <tr><td>1</td></tr> </table>	1/8	1/4	3/8	1/2	3/4	1																					
1/8																																												
1/4																																												
3/8																																												
1/2																																												
3/4																																												
1																																												
1/8																																												
1/4																																												
3/8																																												
1/2																																												
3/4																																												
1																																												
1/8																																												
1/4																																												
3/8																																												
1/2																																												
3/4																																												
1																																												
<p>BS</p> 	<p>螺纹 × 螺纹 Thread Size × Thread Size</p> <table border="1"> <tr><td>1/8</td></tr> <tr><td>1/4</td></tr> <tr><td>3/8</td></tr> <tr><td>1/2</td></tr> <tr><td>3/4</td></tr> <tr><td>1</td></tr> </table>	1/8	1/4	3/8	1/2	3/4	1	<p>BU</p> 	<p>螺纹 × 螺纹 Thread Size × Thread Size</p> <table border="1"> <tr><td>1/8-1/8</td></tr> <tr><td>1/4-1/4</td></tr> <tr><td>3/8-3/8</td></tr> <tr><td>1/2-1/2</td></tr> <tr><td>1/4-3/8</td></tr> <tr><td>1/4-1/2</td></tr> <tr><td>3/8-1/2</td></tr> </table>	1/8-1/8	1/4-1/4	3/8-3/8	1/2-1/2	1/4-3/8	1/4-1/2	3/8-1/2	<p>BW</p> 	<p>螺纹 × 螺纹 Thread Size × Thread Size</p> <table border="1"> <tr><td>1/8-1/8</td><td>1/4-1/2</td></tr> <tr><td>1/4-1/4</td><td>3/8-1/2</td></tr> <tr><td>3/8-3/8</td><td>1/2-3/4</td></tr> <tr><td>1/2-1/2</td><td>3/4-1"</td></tr> <tr><td>3/4-3/4</td><td>3/8-3/4</td></tr> <tr><td>1"-1"</td><td>1/2-1"</td></tr> <tr><td>1/8-1/4</td><td></td></tr> <tr><td>1/4-3/8</td><td></td></tr> </table>	1/8-1/8	1/4-1/2	1/4-1/4	3/8-1/2	3/8-3/8	1/2-3/4	1/2-1/2	3/4-1"	3/4-3/4	3/8-3/4	1"-1"	1/2-1"	1/8-1/4		1/4-3/8											
1/8																																												
1/4																																												
3/8																																												
1/2																																												
3/4																																												
1																																												
1/8-1/8																																												
1/4-1/4																																												
3/8-3/8																																												
1/2-1/2																																												
1/4-3/8																																												
1/4-1/2																																												
3/8-1/2																																												
1/8-1/8	1/4-1/2																																											
1/4-1/4	3/8-1/2																																											
3/8-3/8	1/2-3/4																																											
1/2-1/2	3/4-1"																																											
3/4-3/4	3/8-3/4																																											
1"-1"	1/2-1"																																											
1/8-1/4																																												
1/4-3/8																																												

SCA



管外径 × 螺纹 Tube OD. × Thread Size	
1/2-1/2	
1/8-1/8	
1/4-1/4	
3/4-3/4	
1-1	

SCB



管外径 × 管外径 Tube OD. × Tube OD.	
3/8-1/2	
1/2-1/2	
3/4-3/4	
1-1	

SCC



螺纹 × 螺纹 Thread Size × Thread Size	
3/8-1/2	
1/2-1/2	
3/4-3/4	
1-1	

SCL



管内径 × 螺纹 Tube ID. × Thread Size	
6-01	10-01
6-02	10-02
6-03	10-03
6-04	10-04
8-01	12-02
8-02	12-03
8-03	12-04
8-04	14-03

SCT



管内径 × 管内径 Tube ID. × Tube ID.	
φ 6	
φ 8	
φ 10	
φ 12	
φ 14	
φ 16	
φ 18	

SCU



管内径 × 管内径 Tube ID. × Tube ID.	
φ 6	
φ 8	
φ 10	
φ 12	
φ 14	
φ 16	
φ 18	

SCY



管内径 × 管内径 Tube ID. × Tube ID.	
φ 6	
φ 8	
φ 10	
φ 12	
φ 14	
φ 16	
φ 18	

SCX



管内径 × 管内径 Tube ID. × Tube ID.	
φ 4	
φ 6	
φ 8	
φ 10	
φ 12	
φ 14	
φ 16	
φ 18	

油排 Oil Row



位数 Stations	
2	8
3	9
4	10
5	11
6	12
7	13

SNPC



管外径 × 螺纹 Tube OD. × Thread Size	
4-01	
4-02	
6-01	
6-02	
6-03	
6-04	
8-01	
8-02	
8-03	

SCPC



管外径 × 螺纹 Tube OD. × Thread Size	
6-01	10-02
6-02	10-03
6-03	10-04
6-04	12-01
8-01	12-02
8-02	12-03
8-03	12-04
8-04	14-04
10-01	16-04

SCPU



管外径 × 管外径 Tube OD. × Tube OD.	
φ4	
φ6	
φ8	
φ10	
φ12	
φ14	
φ16	
φ18	

SCWL



螺纹 × 螺纹 Thread Size × Thread Size	
1/8	
1/4	
3/8	
1/2	
3/4	
1	

SCNW



螺纹 × 螺纹 Thread Size × Thread Size	
1/8	
1/4	
3/8	
1/2	
3/4	
1	

SCNL



螺纹 × 螺纹 Thread Size × Thread Size	
1/8	
1/4	
3/8	
1/2	
3/4	
1	

SCLL



管外径 × 螺纹 Tube OD. × Thread Size	
1/8	
1/4	
3/8	
1/2	
3/4	
1	

SCWL-45°



螺纹 × 螺纹 Thread Size × Thread Size		
6-01	10-02	16-04
6-02	10-03	
6-03	10-04	
6-04	12-02	
8-01	12-03	
8-02	12-04	
8-03	14-03	
8-04	14-04	
10-01	16-03	

SCML



管外径 × 螺纹 Tube OD. × Thread Size	
6-01	10-03
8-01	12-03
10-01	8-04
6-02	10-04
8-02	12-04
10-02	14-04
12-02	16-04
6-03	
8-03	

SCWT



螺纹 × 螺纹 Thread Size × Thread Size	
1/8	
1/4	
3/8	
1/2	
3/4	
1	

SCNT



螺纹 × 螺纹 Thread Size × Thread Size	
1/8	
1/4	
3/8	
1/2	
3/4	
1	

SCNX



螺纹 × 螺纹 Thread Size × Thread Size	
1/8	
1/4	
3/8	
1/2	
3/4	
1	